

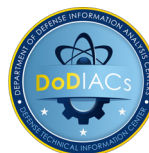

THE HISTORY OF FORWARD-LOOKING INFRARED (FLIR)

Dr. James "Ralph" Teague
and David Schmieder

October 2021



DSIAC

DISTRIBUTION STATEMENT A
Approved for public release; distribution is unlimited.

REPORT DOCUMENTATION PAGE			Form Approved OMB No. 0704-0188		
<p>Public reporting burden for this collection of information is estimated to average 1 hour per response, including the time for reviewing instructions, searching existing data sources, gathering and maintaining the data needed, and completing and reviewing this collection of information. Send comments regarding this burden estimate or any other aspect of this collection of information, including suggestions for reducing this burden to Department of Defense, Washington Headquarters Services, Directorate for Information Operations and Reports (0704-0188), 1215 Jefferson Davis Highway, Suite 1204, Arlington, VA 22202-4302. Respondents should be aware that notwithstanding any other provision of law, no person shall be subject to any penalty for failing to comply with a collection of information if it does not display a currently valid OMB control number.</p> <p>PLEASE DO NOT RETURN YOUR FORM TO THE ABOVE ADDRESS.</p>					
1. REPORT DATE October 2021		2. REPORT TYPE Technical Publication		3. DATES COVERED	
4. TITLE AND SUBTITLE The History of Forward-Looking Infrared (FLIR)			5a. CONTRACT NUMBER FA8075-14-D-0001		
			5b. GRANT NUMBER		
			5c. PROGRAM ELEMENT NUMBER		
6. AUTHOR(S) Dr. James "Ralph" Teague and David Schmieder			5d. PROJECT NUMBER		
			5e. TASK NUMBER		
			5f. WORK UNIT NUMBER		
7. PERFORMING ORGANIZATION NAME(S) AND ADDRESS(ES) AND ADDRESS(ES) Defense Systems Information Analysis Center (DSIAC) SURVICE Engineering Company 4695 Millennium Drive Belcamp, MD 21017-1505			8. PERFORMING ORGANIZATION REPORT NUMBER		
9. SPONSORING/MONITORING AGENCY NAME(S) AND ADDRESS(ES) Defense Technical Information Center (DTIC) 8725 John J. Kingman Rd. Ft. Belvoir, VA 22060-6218			10. SPONSOR/MONITOR'S ACRONYM(S) DTIC		
			11. SPONSOR/MONITOR'S REPORT NUMBER(S)		
12. DISTRIBUTION/ AVAILABILITY STATEMENT Distribution A: Approved for public release; distribution is unlimited.					
13. SUPPLEMENTARY NOTES					
14. ABSTRACT This historical overview of the development of forward-looking infrared (FLIR) technology begins with discussions of the basic principles of infrared (IR) radiation and early IR technology, such as the first IR detectors. Then, the early military development and uses of IR systems in both World Wars are explained, including the main industrial and government contributors to these early systems. Next, the FLIR design progression through the Vietnam War era is described including the development of common module FLIRs which led to the creation of both GEN1 and GEN2 FLIRs. Current trends and future projections in FLIR technology are then highlighted such as their application in urban warfare, persistent surveillance systems, microbolometers, passive and active fused sensors, and artificial intelligence.					
15. SUBJECT TERMS forward-looking infrared, FLIR, FLIR history, infrared technology, IR, World War I IR, World War II IR, common modules, Vietnam FLIR, Hughes Aircraft, Texas Instruments					
16. SECURITY CLASSIFICATION OF: UNCLASSIFIED		17. LIMITATION OF ABSTRACT UNCLASSIFIED	18. NUMBER OF PAGES 127	19a. NAME OF RESPONSIBLE PERSON Vincent "Ted" Welsh	
a. REPORT UNCLASSIFIED	b. ABSTRACT UNCLASSIFIED			c. THIS PAGE UNCLASSIFIED	19b. TELEPHONE NUMBER (include area code) 443-360-4600
Standard Form 298 (Rev. 8/98) Prescribed by ANSI Std. Z39.18			ON THE COVER: <i>(Source: Army National Guard, Maj. Will Cox)</i>		

PREFACE

The decision to write a book on the history of forward-looking infrared (FLIR) technology began at Georgia Tech Research Institute (GTRI) in 2013, when the Military Sensing Information Analysis Center (SENSIAC) program office looked for ways to fill the continuing need to document important defense technology information. SENSIAC was one of several Defense Technical Information Center (DTIC)-funded Information Analysis Centers (IACs) that were chartered to gather and disseminate information to the defense community from their specialty areas. SENSIAC's specialty area was in sensors with a focus on infrared (IR) sensors such as FLIRs, although it was later expanded to include radar and acoustic sensors as well as others. SENSIAC's activity mostly consisted of conducting research in vital defense sensor-related activities and in organizing, conducting, and documenting classified symposia. An important component of their work also consisted of writing reports such as State-of-the-Art Reports (SOARs), which kept the defense community up to date on current sensor technologies. Thus, SENSIAC leadership, with guidance and approval from Jim Howe of the Army's Night Vision & Electronic Sensors Directorate (NVESD), decided that documenting the history of FLIR technology could broaden the perspective of new IR engineers by adding important historical context to the technology discovery process as well as by providing a rudimentary explanation of the technology itself. NVESD and SENSIAC management also believed this historical information would add valuable insight and guidance for navigating the complex interplay of intracompany competition, intergovernmental cooperation, business marketing decisions, and research and development resource allocation. They especially believed those insights held important lessons for the future—far beyond IR technology itself.

***Dr. James "Ralph" Teague and
David Schmieder***

THE AUTHORS

DR. JAMES "RALPH" TEAGUE was the FLIR history project program manager. Dr. Teague has over 46 years of experience in sensor and related technologies encompassing material science to large-scale sensor system integration. He is currently a Principal Research Scientist at Georgia Tech Professional Education (GTPE), providing short courses to the sensor community in detection and tracking systems; laser systems; missile-seeker design; electro-optical (EO)/IR payloads; self-defense systems; and chemical, biological, and explosion detection systems as well as required sensor-related technologies such as detectors, image processing, and optics. Dr. Teague was presented a Pioneer Award in space laser communications in the 1970s and received a Rockwell Pioneer award for his efforts within the IR countermeasures (IRCM) community in the 1990s. He was responsible for the seeker activities at Lockheed Martin in Orlando. Dr. Teague has been an Associate Editor for the Institute of Electrical and Electronics Engineers (IEEE) Aerospace and Electronic Systems publications responsible for sensors, EOs, and radar content.

DAVID SCHMIEDER spent much of his career developing imaging systems and performance metrics for military fire control and targeting devices. His career began at Delco Division of GM on the Army's Main Battle Tank replacement program. He was part of the effort to build laser pulse-gated TV systems for night vision at a time when FLIRs were not yet available. His career continued at Martin Marietta Orlando, now Lockheed Martin, where he was on the team to qualify the company as a second-source supplier of the groundbreaking Common Module FLIR. His team developed several FLIR enhancements, which later became standard modules. Mr. Schmieder was also the lead author of the *Common Module FLIR Design Manual*. He went on to become lead Electro-optical Systems Engineer on the Army's Apache TADS targeting system, which was one of the first high-volume FLIR applications. He also contributed to the Air Force's LANTIRN fixed-wing targeting pod development and to various reconnaissance pods. At Georgia Tech Research Institute, Mr. Schmieder developed now widely used metrics that allow FLIR designs to be optimized to enable more rapid acquisition of targets embedded in clutter. He developed the first professional education courses that taught electro-optical targeting, stealth, and self-protection design principles to practicing engineers and scientists. For that effort he received Georgia Tech's Outstanding Continuing Education Award. Mr. Schmieder has published six journal papers, over 20 symposium papers, including three invited ones, and two book chapters. He was named a Fellow of the Military Sensing Symposia (MSS).

ACKNOWLEDGMENTS

The authors wish to acknowledge the following individuals who were key contributors to FLIR development and to this historical overview of this vital IR technology.

Kirby Taylor (Texas Instruments [TI], later DRS) helped design, install, test, and fly the first gunship FLIRs in the Vietnam War and later helped TI develop the first mass-produced "Common Module" FLIR.

Robert Sendall (Hughes Aircraft [HAC], later Raytheon) led efforts to design and build the first serial scan FLIRs and was most responsible for developing key FLIR optimization metrics that are still used to design modern FLIRs.

Paul Kruse (Honeywell Research Center, later BAE) made the critical breakthroughs that enabled the development of mercury cadmium telluride detectors and the resulting first-generation FLIR. He also invented room-temperature microbolometer focal plane arrays. Both of these contributions changed the course of FLIR history.

Marion Reine (Honeywell Research Center, later BAE) did important work in detector development and carefully documented the many breakthroughs and inventions of his colleague Paul Kruse.

Charles Hanson (U.S. Army Night Vision Laboratory [NVL], now NVESD) was a project engineer on the first-generation Common Module FLIR program and, from that vantage point, was a key witness to its development history.

Steve Jost (General Electric, later Sanders, Loral, LMC, and BAE) facilitated key technology transfer from the French who had developed a breakthrough approach to fabricating second-generation FLIR photodiode detector technology. He used it to produce one of the first second-generation scanning focal plane arrays for Navy aircraft.

Jim Wimmers (Cincinnati Electronics [CE, later L-3]) was a founder and principal operating officer of Cincinnati Electronics. He contributed to and witnessed the development of indium antimonide, both in the form of a discrete detector material and as a part of second-generation focal-plane arrays. This work included the development of key focal-plane array multiplexing technology.

The authors would also like to thank Paul Norton (Santa Barbara Research Center [SBRC], later Raytheon) and Michael Kinch (TI, later DRS) who generously provided permission to use extractions from historical documents they wrote. Others provided both direct and indirect support by sharing their knowledge over a period of many years. They include such well-published IR engineers and scientists as Lucien Biberman, Roger DeWames, Bill Tennant, Mark Greiner, James Ratches, and Ron Driggers.

TABLE OF CONTENTS

REPORT DOCUMENTATION PAGE	ii
PREFACE	iii
THE AUTHORS	iv
ACKNOWLEDGMENTS	v
CHAPTER 1. BASIC PRINCIPLES OF IR TECHNOLOGY	1-1
1.1 Background.....	1-1
1.2 Sources of IR Radiation.....	1-2
1.3 IR Detectors.....	1-4
1.3.1 Examples of IR Systems.....	1-5
CHAPTER 2. EARLY IR TECHNOLOGY	2-1
2.1 Discovery of Invisible Light.....	2-1
2.2 The First IR Detectors.....	2-1
2.3 Theoretical Foundations.....	2-1
CHAPTER 3. EARLY MILITARY IR USE IN WORLD WARS I AND II	3-1
3.1 Background.....	3-1
3.2 Early Detectors.....	3-1
3.3 IR Systems in WWI.....	3-1
3.4 Lead Up to and Use of IR Systems in WWII.....	3-2
3.4.1 German IR Research Program.....	3-2
3.5 Summary of Developments to the End of WWII.....	3-4
CHAPTER 4. POST-WWII IR TECHNOLOGY	4-1
4.1 Introduction.....	4-1
4.2 Increased Investment in Government Laboratories and the Industrial Base.....	4-1
4.3 Improved Radiometric Standards.....	4-2
4.4 Better Communication of IR Research.....	4-3
4.4.1 Conferences.....	4-3
4.4.2 The IR Handbook and Other Publications.....	4-4

4.5 Breakthroughs in Detector Development.....	4-5
4.5.1 PbS Detectors.....	4-5
4.5.2 InSb Detectors.....	4-5
4.5.3 Ge:Hg Detectors.....	4-5
4.5.4 HgCdTe Detectors.....	4-6
4.6 Development of IRST Systems.....	4-7
4.7 Development of Line Scan Mappers.....	4-8
4.8 Development of Performance Metrics.....	4-10
4.8.1 Bar Target Equivalency Criteria.....	4-10
4.9 Summary and Conclusions.....	4-12
CHAPTER 5. VIETNAM-ERA FLIR DEVELOPMENT.....	5-1
5.1 Introduction.....	5-1
5.2 Vietnam War IR Imaging Problems and Solutions.....	5-2
5.3 TI FLIR Development.....	5-4
5.3.1 First FLIR System: FLIR 1.....	5-4
5.3.2 FLIR Design Progression.....	5-6
5.4 HAC FLIR Development.....	5-8
5.4.1 The Advanced FLIR for the Air Force.....	5-9
5.4.2 EO Vision System FLIR for the Air Force B-52 Aircraft.....	5-10
5.4.3 The Discoid Serial Scan FLIR.....	5-11
5.5 Summary of Vietnam-Era FLIR Developments.....	5-12
CHAPTER 6. GEN1 COMMON MODULE FLIR.....	6-1
6.1 Introduction.....	6-1
6.2 Vietnam-Era Contributions.....	6-1
6.3 Early NVL Development Activities.....	6-2
6.4 Emergence of Common Modules.....	6-3
6.4.1 TI Common Module Development Perspective.....	6-3
6.4.2 NVL Common Module Development Perspective.....	6-4
6.4.3 Common Modules Description.....	6-5

6.5 Common Module Detector Evolution.....	6-8
6.6 Summary of GEN1/Common Module History.....	6-9
CHAPTER 7. GEN2 FLIR: READ-OUT INTEGRATED CIRCUIT INVENTION AND SELF-SCANNED FPAs.....	7-1
7.1 Introduction	7-1
7.2 SPRITE Detector Invention.....	7-3
7.3 Multiplexer ROIC Designs.....	7-3
7.3.1 Charge Coupled Device.....	7-3
7.3.2 Charge Injection Device.....	7-5
7.3.3 MOSFET Switch.....	7-6
7.4 Development of GEN2 Self-Scanned FPAs.....	7-7
CHAPTER 8. GEN2 FLIRs WITH COOLED MCT DETECTORS.....	8-1
8.1 Introduction	8-1
8.2 Device Status in the Early 1980s.....	8-1
8.3 Mid-1980s FPA Developments.....	8-2
8.4 MCT Technology Transfer from the French.....	8-3
8.5 The Standard Advanced Dewar Assembly Scanning Module.....	8-5
8.6 Summary.....	8-8
CHAPTER 9. GEN2 FLIRs WITH INSB AND UNCOOLED FPAs, AND SYSTEM PERFORMANCE MODELING ADVANCES.....	9-1
9.1 Introduction	9-1
9.2 InSb FPA Development.....	9-2
9.2.1 Early InSb Detector Fabrication and Applications.....	9-2
9.2.2 Near IR Mapping Spectrometer and Galileo.....	9-3
9.2.3 Spatial Noise.....	9-6
9.2.4 Multiplexer Designers and Si IC Foundries.....	9-7
9.2.5 CE's Novel 2-D FPA Design.....	9-8
9.3 Development of GEN2 Uncooled Detectors.....	9-9
9.3.1 Invention of the Microbolometer.....	9-9
9.3.2 Other Significant Historical Developments in Uncooled Detectors.....	9-10
9.4 Advancements in FLIR Modeling and Analysis.....	9-11
9.4.1 FLIR Modeling Developments Overview.....	9-11

9.4.2 System and Observer Noise Modeling for GEN2 FLIRs.....	9-11
9.4.3 Background Clutter Modeling.....	9-12
9.5 Summary.....	9-13
CHAPTER 10. SUMMARY, CURRENT TRENDS, AND LESSONS FOR THE FUTURE.....	10-1
10.1 Introduction.....	10-1
10.2 Summary.....	10-1
10.3 Current Trends and Future Projections.....	10-2
10.4 Conclusion.....	10-6
REFERENCES.....	R-1
APPENDIX A.....	A-1
Interview with Paul W. Kruse.....	A-1
Appendix A References.....	A-17
APPENDIX B.....	B-1
Eyewitness Account of FLIR Development.....	B-1
B.1 First FLIR.....	B-1
B.2 AC-130 SPECTRE Fire Control Systems, AN/AAD-4, AN/AAD-6, AN/AAD-7.....	B-2
APPENDIX C.....	C-1
First FLIR Optics and Scanner Configuration.....	C-1
APPENDIX D.....	D-1
GEN 1 Common Module Description.....	D-1
BIBLIOGRAPHY.....	E-1
ACRONYMS AND ABBREVIATIONS.....	F-1
FIGURES	
Figure 1-1. Atmospheric transmission plot.....	1-1
Figure 1-2. Planck blackbody radiation function.....	1-3
Figure 1-3. A representative jet aircraft signature illustrates the varied contributions from both skin self-emissions and ground emission reflections and also the dominant contributions from the plume and hot exhaust parts when viewed from the rear.....	1-4
Figure 1-4. Sniper targeting pod.....	1-5

Figure 1-5. Apache attack helicopter Modern Target Acquisition and Designation Sight targeting system..... 1-5

Figure 1-6. USAF Predator surveillance drone..... 1-5

Figure 1-7. F-35 withIRST and Missile Warning Receiver Distributed Aperture Sensor..... 1-5

Figure 1-8. Rifle with thermal weapon sight..... 1-6

Figure 3-1. U.S. Army sniper scope used in the Pacific Theater near the end of WWII..... 3-3

Figure 3-2. 1940s U.S. Army "snooperscope"..... 3-4

Figure 3-3. German Panzer FG 1250 searchlight and scope..... 3-4

Figure 3-4. U.S. VB-6 IR guided bomb..... 3-5

Figure 4-1. 1978 IR Handbook..... 4-4

Figure 4-2. Vought Crusader F-8E variant..... 4-8

Figure 4-3. Illustrations of an IR mapper. An image scanned by a rotating mirror is transferred to film via a synchronously scanning glow tube modulated by the IR detector output. Forward motion of the aircraft adds the second dimension to the raster scan..... 4-9

Figure 4-4. A visible-band aerial photograph of the TI plant and the corresponding mapper image..... 4-9

Figure 4-5. Johnson's Bar Target Equivalency Criteria determined resolution requirements for various target acquisition tasks..... 4-11

Figure 5-1. First flyable FLIR made by TI. It was the first FLIR to be tested on an AC-47 gunship (1965). Right inset shows Kirby Taylor standing beside the gunship at Bien Hoa Air Base, Vietnam..... 5-5

Figure 5-2. Image from first flyable TI FLIR..... 5-5

Figure 6-1. The HHTV, AN/PAS-7..... 6-2

Figure 6-2. The AN/PAS-7 display..... 6-2

Figure 6-3. TI Common Module FLIR-equipped TOW sight..... 6-4

Figure 6-4. Serial-scan FLIR concept of operation..... 6-5

Figure 6-5. Parallel-scan FLIR concept of operation..... 6-5

Figure 6-6. Set of common modules for man-portable FLIR configurations..... 6-5

Figure 6-7. Typical layout for a common module FLIR..... 6-6

Figure 7-1. SPRITE Principle of Operation: Detected photoelectrons are made to drift at a velocity that matches the image scan rate to effectively implement TDI..... 7-3

Figure 7-2. CCD Operation..... 7-4

Figure 7-3. CID Operation..... 7-5

Figure 7-4. MOSFET switch device architecture..... 7-6

Figure 8-1. Several InSb FPA formats from Lockheed Martin Santa Barbara Focal Plane. Navy and Air Force staring FLIRs for targeting and navigation employed InSb FPAs in 480x640 format or larger. InSb dominated the large-format staring market with excellent performance at a reasonable cost..... 8-2

Figure 8-2. The F-14D IRST FPA consisted of four 64-element modules of LWIR MCT diodes and an Amber/GE designed readout. This was the first production LWIR diode-based FPA in a production U.S. sensor, circa 1991..... 8-4

Figure 8-3. The Javelin antiarmor missile has a staring seeker 64x64 LWIR FPA from Raytheon Vision Systems in the missile and a scanning sensor with a linear LWIR FPA from DRS in the command launch unit. The target is acquired with the command launch unit FLIR, which relays that information to the seeker, which tracks the target and determines the point of impact..... 8-4

Figure 8-4. 480x640 QWIP FPA and typical "peaked" spectral response curve (right). Perhaps the lowest-cost LWIR technology, the QWIP had low QE and higher dark current than comparable MCTs..... 8-5

Figure 8-5. President George Bush learning the basics of MBE MCT from Professor Jan Schetzina from North Carolina State University. This custom machine was an early U.S. attempt to explore this new technology funded by GE..... 8-6

Figure 8-6. The principal GEN2 Common Module IDCA, contained a 480x4 LWIR MCT FPA, in a sealed Dewar with cryocooler and drive electronics. The additional pixels on target and TDI feature provided a significant range advantage over GEN1 imagers..... 8-6

Figure 8-7. Bradley GEN2 FLIR with 480x4 SADA II FPA. GEN2 was a significant improvement over GEN1 night sights and enabled engagement at longer ranges with improved probability of target identification..... 8-7

Figure 8-8. F35 Distributed Aperture Sensor employed multiple staring InSb-based FPAs. Larger-format arrays provided enhanced target acquisition range allowing weapons platforms to engage from the relative safety of higher altitudes..... 8-7

Figure 9-1. Galileo satellite with IR detector array for the NIMS..... 9-4

Figure 9-2. Multiplexed InSb detector array for the VIMS..... 9-5

Figure 9-3. NUC Process..... 9-7

Figure 9-4. Front side illuminated and reticulated IR detector array from L-3 CE patent 5,227,656, 13 July 1993..... 9-9

Figure 9-5. Microbolometer FPA showing microbridge design..... 9-10

Figure 10-1. ARGUS-IS has 368 5-megapixel FPAs that provide 1.8 gigapixels on the ground with a resolution of 4 in. at 15 kft in the visible/near-IR band. One planned MWIR version would provide over 100 cooled FPAs each with 18 megapixels..... 10-3

Figure 10-2. The Lepton microbolometer is an example of how small IR imaging sensors can be made. They can be used for covert, unattended operation in either remote or urban locations and connected to the battlefield network..... 10-3

Figure 10-3. In a passive/active targeting system, the FLIR is used for passive target detection and the lidar is used for active identification..... 10-5

Figure 10-4. The U.S. Air Force LITENING G4 pod uses active imaging for extended-range target identification..... 10-5

Figure C-1. FLIR I Objective Lens Design–Schmidt-Cassegrain..... C-1

Figure C-2. FLIR I Three-Element Staggered Detector Array..... C-2

Figure C-3. FLIR I Kennedy Scanner Implementation..... C-3

Figure C-4. Kennedy 2-Axis Scanner Patent Drawing..... C-4

Figure D-1. Layout of Common Module Detector Pixel..... D-1

Figure D-2. 60-Element Common Module TOW Detector Array..... D-2

Figure D-3. Common Module Detector/Dewar with cover removed..... D-2

Figure D-4. Common Module One-Watt Cryocooler. (Source: U.S. Army)..... D-2

Figure D-5. Common Module Detector/Dewar/Cooler Assemblies for the 180-element version and the
60-element version..... D-3

CHAPTER 1. BASIC PRINCIPLES OF IR TECHNOLOGY

1.1 BACKGROUND

This history of forward-looking infrared (FLIR) begins with a brief summary of infrared (IR) technology to enable readers new to the field to better understand and grasp the development history. The intent of this first chapter is simply to familiarize readers with the most basic principles of FLIR technology and nomenclature, so they can understand the significance of the historical developments. The term "forward-looking infrared" generally refers to tactical image-forming cameras that provide fast, successive frames of imagery based primarily on object and scene self-emissions. This discussion is not a complete introduction to the field, but it provides some understanding of both the capabilities and limitations of FLIR technology, and provides background perspective for the reader.

Figure 1-1 shows a plot of the atmospheric transmission of a standard atmosphere at sea level over a 10-km path. The transmission plot is overlaid with portions of the electromagnetic (EM) spectrum nominally beginning with the ultraviolet region and extending through the radio-frequency (RF) region.

The word "infrared" comes from the Latin word *infra*, which means below, and the English word "red," which refers to that part of the spectrum lower in frequency (and therefore longer in wavelength) than the red portion of the visible region. The visible region extends from 0.4 to 0.7 μm . Since red is the longest wavelength that can be seen in the visible, IR refers to a particular region of the EM spectrum beyond the visible. This region is divided into subregions, which have no universal definition, but the definitions given here follow current, general usage. Typically, at least four subregions can be found as indicated in Figure 1-1: near IR (NIR), short-wave IR (SWIR), mid-wave IR (MWIR), and long-wave IR (LWIR).

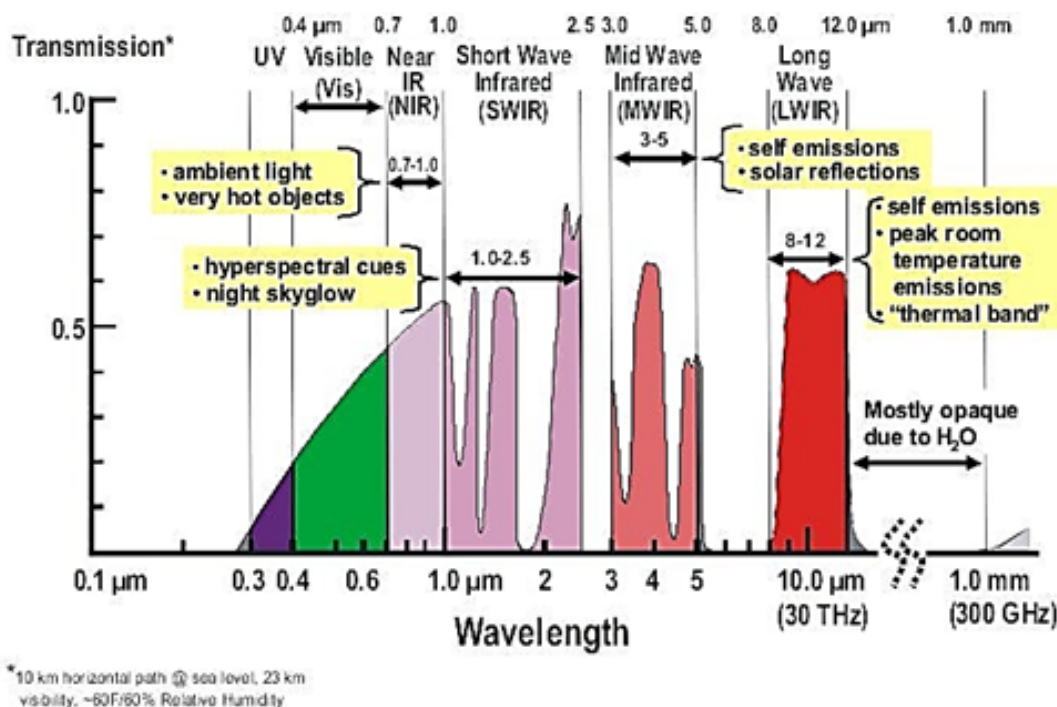

Figure 1-1. Atmospheric transmission plot (Source: Schmieder [1]).

Generally, the subregions are defined by the existence of a useful atmospheric transmission "window." These windows, however, are sometimes subdivided according to detector response capabilities. For instance, most recent nomenclature defines NIR as nominally the 0.7–1.0- μm region in accordance with the response of silicon detectors (but without the visible band response of silicon detectors) and night vision goggles (0.6–0.9 μm). SWIR (1.0–2.5 μm) had not been widely used before the advent of hyperspectral imaging (HSI) systems. Early HSI favored that region for day target discrimination. Now, night ambient light-amplifying sensors exploit that region as well and use the higher-ambient illumination available from night skyglow.

The MWIR and LWIR regions dominate current tactical military IR applications. The MWIR region, nominally 3.0–5.0 μm , and the LWIR 8–12- μm region are defined only by windows in the atmosphere. Beyond 12 μm there is a large gap between where the LWIR band ends and where the near millimeter wave RF band begins. The gap is due to a severe atmospheric absorption "wall" region that extends out to and helps define the beginning of the RF band. For tactical applications within the Earth's atmosphere, the IR community considers the "IR" spectral region to extend roughly from 0.7 μm , where the visible band ends, to about 14 μm , where the atmospheric absorption wall begins. For extraterrestrial space applications where atmospheric windows don't apply, the definition of the IR spectral region readily extends out to almost 30 μm , and the region between 14 and 30 μm is called the very long-wave IR (VLWIR).

1.2 SOURCES OF IR RADIATION

Sources of IR radiation ultimately define the application domain for IR technology; those sources are generally anything that produces heat. Fortunately, for the usefulness of IR technology, that includes almost everything. For instance, most people know from personal experience that hot objects radiate heat because they can feel it, but they can't see that object's self-emissions unless it is very hot like a fireplace poker. Therefore, it is less obvious that objects at room

temperature also emit radiation because those objects are in radiative equilibrium with their observer, and there is no net radiation transfer. If that person stood next to a cold exterior window inside a warm enclosure on a cold day, they would readily feel the unequal exchange. Nevertheless, radiative nonequilibrium is not a requirement for being able to detect IR radiation. It is only required that objects have an apparent temperature difference from their background. The temperature difference can be the result of either temperature and/or emissivity differences. Objects need only to emit slightly more or less than their immediate backgrounds to be detectable. For example, even the "first generation" of IR imagers could easily sense a 0.1°C apparent temperature difference.

The principles of blackbody radiation govern how much IR light is produced by an object of a given temperature. Figure 1-2 from *The Infrared & Electro-Optical Systems Handbook* [2] shows the classic Planck blackbody radiation function, which plots radiant emittance versus wavelength. There are several significant features of this function. First, the peak shifts to the left with increasing temperature such that at 6,000 K, the temperature of the Sun, the peak matches the center of the human eye response at 0.5 μm . Is it any wonder that nature evolved the eye to respond there? Secondly, note that at 300 K, the nominal temperature of terrestrial objects or so-called "room-temperature," radiation peaks at near 10 μm . This latter peak suggests that the 8–12- μm atmospheric window is a fruitful spectral region for detection of IR radiation, and indeed it is, although nearby regions are also useful. Finally, note that objects at very cold temperatures, such as space objects at about 170 K in the Earth's shadow, can be expected to emit radiation that peaks near 17 μm ; that is why many current space observation satellites exploit the VLWIR spectral region. The much lower absolute radiation at this temperature is not as much of a hindrance as one might think, given that the background of space is only 4 K, so the contrast is very large.

Note that not all objects emit radiation in accordance with the Planck function as plotted with unity emissivity. In fact,

$$W_{\lambda}(\text{W cm}^{-2} \mu\text{m}^{-1}) = \frac{2\pi hc^2}{\lambda^5} \frac{1}{e^{ch/\lambda kT} - 1}$$

Where:

W_{λ} = Spectral Radiant Emittance (radiated into a hemisphere)

λ = Wavelength, μm

h = Planck's Constant = 6.626×10^{-34} W sec²

T = Absolute Temperature, K

c = Velocity of Light = 2.998×10^{10} cm sec⁻¹

k = Boltzmann's Constant = 1.381×10^{-23} W sec K⁻¹

(Single Photon Energy = hc/λ)

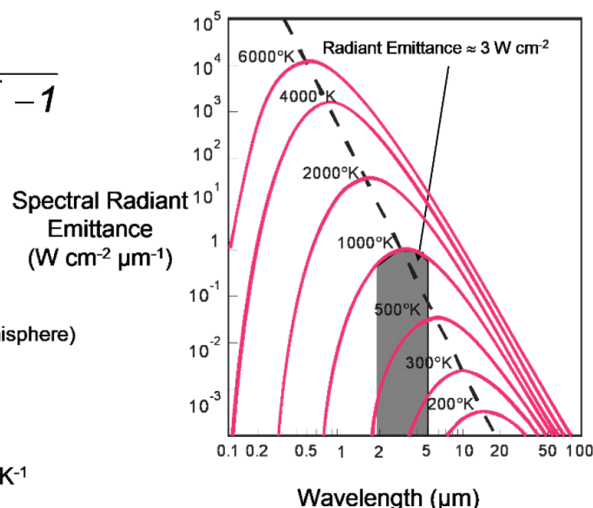

Figure 1-2. Planck blackbody radiation function (Source: Schmieder and Walker [2]).

virtually none of them do. For instance, actual emission spectra depend upon the shape of an object's spectral emissivity characteristics and that shape is seldom that of a pure blackbody. In fact, an object's emissivity is a strong function of its material properties and not only seldom reaches unity but varies considerably with wavelength. Hence, most objects are called "selective radiators" whose emissions are strongly dependent on the spectral shape of their emissivity. If an object does happen to have a shape close to that of a blackbody, it almost always has less than unity emissivity, and is referred to as a "graybody." Hence, the terms *blackbody* and *graybody* are idealizations.

These spectral radiation characteristics are most important when dealing with gaseous emissions such as those coming from a jet engine plume. Jet aircraft have unique signature sources that, for instance, drive the design of missile seekers. Figure 1-3 shows the variability and complexity of a jet aircraft signature. Note that from the rear, it is dominated by the selective radiation from gaseous plume combustion products CO₂ and H₂O and graybody radiation from the hot exhaust region. From the front, the fuselage blocks a large portion of the plume and engine exhaust parts, but there are

graybody emissions from the aerodynamically heated skin combined with reflections of ground emissions off the skin. In higher engine power settings, the gaseous plume emissions extend sufficiently beyond the obscuration of the fuselage and can be observed even from most frontal aspects. The plume signature is dominated by CO₂ gaseous emissions and so is confined to the MWIR band.

IR signatures range from the simple to the very complex such that the spectral band that might work well for one sensor might not work at all for another. An example of a simpler signature is that of a typical ground armored vehicle, such as a tank. When viewed from the side opposite the engine exhaust, the signature looks very much like a graybody. It would have a warm temperature if, for instance, the tank had been sitting in the sun or run for a long period. The signature could have a low temperature if the tank was exposed to cold air overnight because it retains a cold hull and turret for a long time due to its large thermal mass. In either case, the apparent signature would be large because signature is the difference between the object and its background. In contrast to the tank's simpler signature, the jet aircraft signature shown in Figure 1-3 illustrates signature complexity. It took

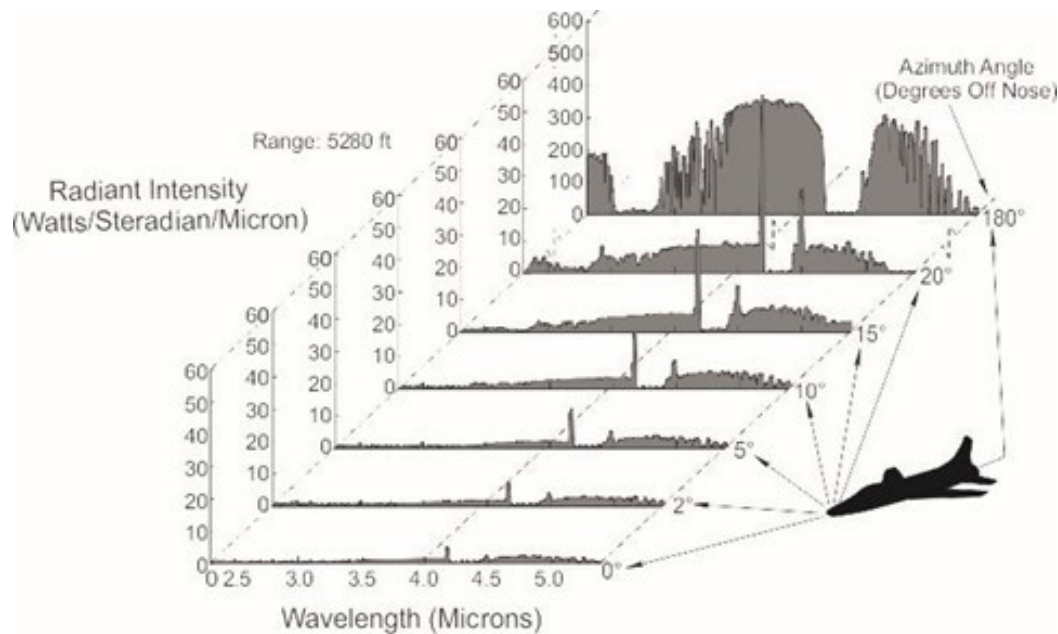

Figure 1-3. A representative jet aircraft signature illustrates the varied contributions from both skin self-emissions and ground emission reflections and also the dominant contributions from the plume and hot exhaust parts when viewed from the rear (Source: General Dynamics).

many decades after IR detectors were developed for designers to fully appreciate the challenges facing IR technology due to both the variability and the complexity of signatures.

1.3 IR DETECTORS

Of course, there would be no IR technology if it were not for the development of IR detectors. This book will describe the fascinating process of insight and luck that led to the development of modern detectors. For now, a summary of only the most general types will provide the background needed to appreciate the history that follows.

There are two very broad categories of detectors: thermal and quantum. Thermal detectors are essentially miniature thermometers that detect radiation from the heat that objects generate when absorbing light. Quantum detectors are based on semiconductors, which absorb photons at the subatomic level and cause electrons to be raised from the valence band to the conduction band where they can be detected as a current or voltage change. Both detector types are widely used in modern FLIRs. The main type of

thermal detector is a bolometer, which changes resistance with a change in temperature. That resistance change is then sensed by passing a current through it. Although thermal detectors are inexpensive and can be operated at room temperature, they typically have a slow response time. Quantum detectors require a cryocooler to operate below 200 K but are more sensitive and have a faster response time than thermal detectors.

Quantum detectors can be further divided into at least three types: photoconductive (PC), photovoltaic (PV), and photoemissive. PC detectors operate by developing a change in resistance in proportion to the amount of incident light. Like bolometers, the resistance change is detected by passing a current through it. PV detectors, however, have a p-n junction like roof-top solar cells and can generate either a current or a voltage from their conversion of photons into photoelectrons. Photoemissive detectors operate by ejecting an electron from their surface when a photon is absorbed. The photons are accelerated by an electric field and are converted into visible light when they impinge on a phosphor screen.

Although the more common detector types are PC, PV, photoemissive (quantum detectors), and bolometric thermal detectors, there are other sensing mechanisms. However, knowledge of these common types is helpful in understanding the history of IR development.

1.3.1 Examples of IR Systems

IR imaging systems include targeting systems (FLIRs) (Figures 1-4 and 1-5), surveillance systems designed for either warning or intelligence gathering (Figure 1-6), or IR search and track (IRST) systems, used mostly on ships and aircraft (Figure 1-7) for both detection and tracking functions. FLIRs are most commonly used for target detection and identifica-



Figure 1-6. USAF Predator surveillance drone (Source: U.S. Air Force).



Figure 1-4. Sniper targeting pod (Source: U.S. Air Force photo/Senior Airman Noah Johnson).



Figure 1-7. F-35 with IRST and Missile Warning Receiver (MWR) Distributed Aperture Sensor (DAS) (Source: U.S. Air Force photo/Senior Airman Christopher Callaway).



Figure 1-5. Apache attack helicopter Modern Target Acquisition and Designation Sight (MTADS) targeting system (Source: U.S. Army Photo/Brigitte Rodriguez).

tion—a process called “target acquisition.” They then serve as fire-control systems that keep a crosshair on the target for engagement with options that include gun fire, laser designation for missile homing, or handoff to other IR homing seekers. Surveillance, warning, and IRST systems often form images like FLIRs do, but differ, albeit sometimes only slightly, by mission application. For instance, surveillance systems are IR cameras used specifically for reconnaissance and intelligence gathering. Warning systems are used to detect threat missile launches, and IRSTs are cameras with a large field-of-

view and therefore often low resolution.IRSTs typically lack long-range target identification capability but have a wide field-of-regard to enhance search and subsequent target tracking. The foregoing systems are the main focus of this history because they most heavily influenced the path of FLIR development. However, there are other important types of imaging systems including such equipment as night driving devices, rifle scopes (Figure 1-8), and unattended sensors covertly placed in hostile territory and used to observe insurgent movements.

There is much overlap of these latter systems in implementation, mission, and enabling technology. Accordingly, the following FLIR history discussions reflect this overlap when tracing key developments. This brief summary, like the previous discussion of basic IR principles, provides the reader with some knowledge and understanding of IR system technology, and some nomenclature, to better understand the significance of the historical developments discussed in succeeding chapters.



Figure 1-8. Rifle with thermal weapon sight (Source: U.S. Army/982nd Combat Camera Company).

CHAPTER 2. EARLY IR TECHNOLOGY

Sections 2.1 through 2.3 discuss early discoveries that enabled the development of FLIR technology. These sections provide discussion of the early technology base to provide perspective on what had been known about the physics and phenomenology that enabled FLIR development to proceed. The references and bibliography provide greater detail about earlier, relevant technology.

2.1 DISCOVERY OF INVISIBLE LIGHT

Sir William Herschel was the first to officially report the discovery of IR radiation over 215 years ago when he experimented with a thermometer. He built a crude monochromator that used the thermometer as a detector so he could measure the distribution of energy in sunlight. According to Rogalski [3], Herschel [4] wrote in April 1800 that "Thermometer No. 1 rose 7° in 10 minutes by an exposure to the full red coloured rays. I drew back the stand.... Thermometer No. 1 rose, in 16 minutes, 8 3/8° when its centre was 1/2 inch out of the visible rays" [4]. He was surprised to observe that the thermometer still rose when exposed to a region of the spectrum that extended beyond the visible. Rogalski's research uncovered other earlier successes with the discovery of the IR region, but those efforts were never documented and so were not officially recognized. For instance, the Italian scientist Marsilio Ladrioni in 1777 and later others, supposedly discovered the region beyond the visible also using a thermometer. However, Herschel got the credit for discovering IR radiation because he documented his findings. This fact demonstrates the importance of documenting discoveries in recognized publications to ensure that proper credit is assigned.

2.2 THE FIRST IR DETECTORS [5]

Historical literature reveals the fascination at the time with the exploration of invisible light. This fascination motivated research and it first led to the development of detectors

based on the thermoelectric effect exploited by thermocouples now most commonly used for flame detection in gas furnaces and water heaters, but also used (in reverse) for refrigeration in portable coolers. In the early to mid-1800s, thermocouples were good enough radiation detectors to detect heat from a person at a distance of 30 ft. Later in the 1800s, bolometers were developed that could detect the heat from a cow at a quarter mile.

Astronomers were among the first to employ these early IR detection devices. They used thermocouples to detect IR emissions from the Moon as focused by telescopes and learned to make filters that could block visible band light. In the early 1900s, astronomers could detect several hundred stars in the IR. Later, astronomers used thermocouples to measure the surface temperature of planets and thereby gain insight into their geological characteristics. As will be seen in subsequent IR history discussions, thermocouples were just the beginning of a long and arduous detector development process that continues today.

2.3 THEORETICAL FOUNDATIONS [6]

The most important theoretical underpinnings of IR technology were formed in the early 1900s. Physicist Wilhelm Wien had earlier found that blackbody spectral radiation reached a peak at an intermediate wavelength rather than at either extremity of the overall spectrum of emissions. He found that the wavelength dependence of radiation emission was inversely proportional to temperature. Hence, hot objects like the Sun's spectral emissions peaked at a much shorter wavelength than colder objects like the Earth. Lord Rayleigh attempted to predict the shape of the spectral emission curve at longer wavelengths using classical physics principles and showed that the level of spectral emissions was inversely proportional to wavelength raised to the fourth power. Sir James Jeans later improved on Rayleigh's model and added a proportionality constant. The combined function became known as the Rayleigh-Jeans Law. Unfortunately, the law did not match experimental data because it predicted that emissions would grow exponentially to infinity as the wavelength

got shorter. Of course, the law not only failed to match measurements, it was physically impossible and became known as the UV catastrophe. The solution remained a puzzling mystery until Max Plank found the explanation.

Plank's breakthrough that explained the flaw in the Rayleigh-Jeans Law was his epiphany that energy could only be emitted in quantized form. As a result of this breakthrough, Plank concluded that no energy could be emitted until its energy was large enough to escape. Since the quanta at lower wavelengths contained higher energy, they could not be emitted in larger quantities until the temperature increased. Therefore, the number of quanta emitted at any given temperature would be limited, and the energy dependence on wavelength forced the blackbody spectral radiation curve lower as wavelength decreased.

Plank's discovery arguably helped Albert Einstein to further conclude that light must be quantized as well. This conclusion led him to explain the photoelectric effect, which posits that light quanta (later called photons) of sufficient energy can force electrons to be emitted from a material's surface into free space. Einstein proposed this explanation knowing that it was not the rate of photons impinging on a material's surface that made this happen but, instead, it was the wavelength because ejection could happen even if the rate were low. It was later seen that these quanta raise valence electrons to the conduction band inside a material, and this also became known as a manifestation of the photoelectric effect. The photoelectric effect is the basic underlying principle for how modern IR quantum detectors work. Einstein was awarded a Nobel Prize for discovering it.

The remaining chapters discuss how the application of these fundamental discoveries led to the invention of IR sensors and ultimately to the development of modern FLIRs.

CHAPTER 3. EARLY MILITARY IR USE IN WORLD WARS I AND II

3.1 BACKGROUND

Interest in IR technology prior to about 1910 was widely dispersed, and development was sporadic and haphazard until its potential military applications were recognized. Barr and Arnquist [6, 7] found that research programs established during World War I (WWI) focused first on covert communication devices that led to field evaluations, but apparently little deployment. However, according to Hudson [8], the period between 1910 and 1920, thus overlapping WWI, was rich with patent disclosures that exploited IR for object detection to include aircraft, ships, personnel, artillery, and even icebergs. Hudson reported that patents during that period included communications equipment, but also disclosed other militarily useful devices for intrusion detection and "the guidance of aerial torpedoes" or what we now call guided missiles. The more germane predecessor to today's IR applications was the IRST, which was developed by the British during WWI, though it was not called that at the time. According to Hudson, these early systems could detect aircraft out to about a mile. Military IR research and development were firmly entrenched by the end of WWI. However, it was not until World War II (WWII) and events shortly thereafter that progress was sufficient to lay the groundwork for what is today's modern IR technology.

3.2 EARLY DETECTORS (PHOTOCONDUCTIVE, PHOTOVOLTAIC, PHOTOEMISSIVE, BOLOMETRIC)

IR technology begins with the development of suitable detectors. The principles of three of the four main detector types were in place by WWI: photoconductive, photovoltaic, and bolometric. (The fourth type was photoemissive.) As discussed in Section 1.3, in response to incident photons that raise electrons to the conduction band in quantum detectors, photoconductors sense a change of resistance; photovoltaic detectors sense a change in voltage or current across a p-n

junction; and bolometric thermal detectors sense a change in resistance to electric current when the incident photons change their temperature (as do other unintentional sources of heat). Smith reported the first discovery of photoconductivity in an 1873 paper in *Nature* [9], although detectors using the principle were not invented until much later [7, 9]. Bose patented the first IR photovoltaic detector in 1904 using naturally occurring lead sulfide (PbS) [8, 10]. Although photoconductivity and the IR photovoltaic detector would later be viewed as major discoveries, they were largely ignored at the time.

The first practical detectors began with the discovery of bolometers [7, 10]. Bolometric detectors were invented by famed astronomer Samuel P. Langley in 1878 [6]. Langley was able to detect the heat from a cow at the impressive distance of a quarter mile. He used his bolometer to discover new atomic and molecular absorption lines in the IR and attempted to measure the temperature of the Moon with it. All three of these detector types (photoconductive, photovoltaic, and bolometric) now play a key role in the modern application of IR technology.

The other major detector type, photoemissive, was not discovered until shortly after WWI. Recall that photoemissive detectors directly exploit the photoelectric effect by detecting electrons externally ejected by special photocathode materials. Their discovery was the basis for image intensifiers, which amplified ambient light first in the visible and, later, in the near IR, but only out to about 1.3 μm . The photoemissive detector was discovered in the U.S. in the 1920s and had an impact in WWII when the Germans deployed it early in the war. Ironically, the U.S. finally did so in the Pacific just as the war was about to end.

3.3 IR SYSTEMS IN WWI

The military first showed interest in IR devices during WWI when it became apparent that invisible light from IR signaling devices could be useful. However, these devices did not appear to get much attention for what was arguably later

thought of as the Holy Grail of IR, i.e., seeing in the dark. Signal communication was the first military application of IR in the U.S. according to Arnquist [7]. This application was enabled when T. W. Case invented the photoconductive detector in 1917 from thallous sulfide (Tl_2S) [11]. It was used to demonstrate a covert blinking communication device for the U.S. military that could transmit and receive at an effective two-way range of 18 miles [7] and later to also transmit voice signals. This detector was subsequently used in the field to covertly help guide planes to landing strips and to guide ship convoys.

The successful use of Tl_2S detectors also apparently stimulated foreign interest in the IR and motivated Russia, Italy, and England to develop similar detectors from this material after the war. The Germans, who were to later lead the world in photoconductive detector development, apparently only looked at selenium photoconductors [7] for visible communications during this period. Rogalski [12] claimed the British developed the first, what must have been fledgling, IRST in 1914 using a bolometer. While little information is available, this IRST could well have been the first attempt to use IR to see objects in the dark.

Shortly after the war, in the U.S., General Electric (GE) reportedly [13] also built an experimental aircraft detection device that could locate a light bomber at a range of 22 miles. However, most IR efforts languished because radar was seen as the more promising sensor technology. Although seeming to make little headway in WWI, the development of IR technology for military applications was firmly established.

3.4 LEAD UP TO AND USE OF IR SYSTEMS IN WWII

D. J. Lovell of The University of Michigan provided a noteworthy summary of U.S. IR technology development from just prior to WWII to the postwar period [14]. The U.S. Air Force Office of Scientific Research had the foresight to fund Lovell's historical account of IR technology development in 1968 before it was forever lost. Lovell's account has the distinction of resulting from numerous personal interviews with such

key players in the U.S. as Robert Cashman and Henry Levinstein, and from Germany, Edgar Kutzscher. This distinction, he observed, provided a broader understanding than would otherwise have been possible from merely reading the archival literature. He also pointed out the importance of what was to later become a hallmark of progress in U.S. IR technology development, i.e., "the curious stimulus afforded by the inter-communication of results" among often competing interests. These communications were fostered by classified symposia (the Infrared Information Symposium [IRIS] and later the Military Sensing Symposium [MSS]), which would become key sources of IR information dissemination.

While Lovell's interviews were important, not to be minimized is Arnquist's IR history survey [7] published in a 1959 Institute of Radio Engineers (IRE) proceedings, which was based on papers found in the archival literature. The remainder of this chapter is largely an abridged collection of observations taken from both Lovell's and Arnquist's research.

3.4.1 German IR Research Program

Germany resumed its military IR program in about 1932. It exploited PbS first in natural crystal form and later as chemically deposited photoconductors. Shortly thereafter, German scientists discovered that lead selenide ($PbSe$) also had favorable detector qualities. During this period, they found that cooling either by using solid carbon dioxide (195 K) or liquid nitrogen (LN2) (77 K) would improve IR detection sensitivity and incorporated those cooling methods into devices. Bolometers were also developed, which enabled Germany to build ground sensors for detecting aircraft and ships. Aircraft sensors were developed to direct searchlights for anti-aircraft fire. Airborne versions were also used to develop air-to-air "IRSTs" for night fighters, and both air-to-air and air-to-ground missile seekers (although no missiles) were ultimately mass produced with those capabilities. According to Johnson [15], near the end of the war, some PbS systems were also used along coastlines to detect ships and aircraft.

Kiel IV and PbS Detector Development. Only a few IRSTs were built, but the scanning Kiel IV night fighter system using PbS almost made it into production before the war ended. By 1944, 1,000 PbS cells were being produced annually [16]. The Kiel IV was developed by Kutzscher's group at a company in the city of Kiel. It used PbS photoconductors perfected by Kutzscher while at the University of Berlin. Unfortunately, Kiel was in that part of Germany later occupied by Russia, and so the Russians were the beneficiaries of equipment, data, and reports owned by Kutzscher's group. This situation gave Russia a boost in IR development that benefitted them throughout the Cold War that followed. However, Kutzscher and several of his colleagues escaped to the West and arguably gave the U.S. an even greater windfall of expertise. This contribution contrasts with the rather slow progress in U.S. photoconductor development during the war. Robert Cashman at Northwestern University began work with Tl_2S films in 1941 and, in 1944, he considered PbS but did not fully embrace it until he and others found out about German progress after the war.

German PbS detector developments prior to and during WWII were based largely on empirical studies and fabrication trial and error rather than on theoretical insight since basic semiconductor theory was not well understood. Accordingly, recipes were developed experimentally, and key processes became more of an art than a science. (Some would say detector material understanding is still more art than science as of this writing.) Many groups were involved including university laboratories and private companies. Nevertheless, Lovell claims that productive interchange was maintained among all groups through organized meetings and published proceedings. This interchange and sharing of empirical data accelerated progress, thus partly mitigating the lack of a guiding theoretical understanding of semiconductors. It was fortuitous for the Germans that they did not spend much time trying to understand the physics of PbS detector material since they are not yet well understood. Various organizations in the U.S. have only recently (circa 2010) started to reexamine PbS because of the promise the material holds

for high-operating-temperature, low-cost applications such as for missile-launch warning receivers.

Electro-Optical (EO) Converter Tubes. These German efforts revealed that there was still much that remained to be understood. EO converter tubes emerged in the late 1920s, and practical EO devices were being made by the mid-1930s. The development of EO converter tubes initially discouraged the development of photoconductive detectors because EO converter tubes seemed more promising. EO converter tubes use a semitransparent photocathode to absorb photons that then eject electrons and are therefore often referred to as photoemissive devices. The electrons are accelerated, sometimes through multiple amplification stages, before impinging on a phosphor screen where they are converted into visible light. The U.S., Britain, Russia, and Germany were all active in their development. The discovery of a stable cathode consisting of cesium-oxygen-silver (Cs-O-Ag), which was called S-1, provided response in the NIR to about 1.3 μm . The Radio Corporation of America (RCA) began producing converter tubes in 1942 [7], and they were used in rifle sights for night viewing in "sniperscopes" and "snooperscopes" (Figures 3-1 and 3-2, respectively), much like the German Vampir and Panzer FG 1250 (Figure 3-3). The converter tube was



Figure 3-1. U.S. Army sniperscope used in the Pacific Theater near the end of WWII (Source: *Popular Science Magazine*).



Figure 3-2. 1940s U.S. Army "snooperscope" (Source: U.S. Army).



Figure 3-3. German Panzer FG 1250 searchlight and scope (Source: Williams [17]).

also used for night navigation. Note that these photoemissive devices did not rely on object self-emissions but only on amplified ambient light such as moonlight, starlight, or reflections from artificial illumination sources such as search lights. Germany used these devices early in WWII to equip

their armored vehicles [17] for night fire control as shown in Figure 3-3. It was only much later that they equipped their soldiers with portable weapon sights such as the Vampir. The U.S. was slower to deploy similar equipment and only managed to deploy riflescopes in the Pacific late in the war, but according to Johnston [18], they were very effective.

A major drawback of early converter tubes was their lack of EO or IR light detection sensitivity. Almost all applications required the use of a covert source of active illumination because they could not otherwise operate under ambient starlight conditions. Accordingly, not only were the collection optics large, but they often had to be coupled with even larger illumination lamps.

GE developed an innovative system that used an argon-hydrogen flash lamp where the flash duration could be controlled down to a microsecond. It was used to make an "IR radar" that not only could illuminate the target but could measure its range and was effective out to ranges exceeding a mile. It never went into production but was arguably the forerunner of today's ladars (laser radars) and laser range-finders. The converter tubes were the forerunners of today's microchannel plate image intensifiers, which operate on the same principles as converter tubes but with much more compact components and much more sensitive photocathodes. These modern versions function well with only ambient illumination unless used in overcast, dusty, or foggy conditions.

3.5 SUMMARY OF DEVELOPMENTS TO THE END OF WWII

The period from WWI to the end of WWII was significant in that there were detector advances that played important roles in early night vision devices and in the development of precision-guided missiles,¹ despite the lack of understanding of semiconductor physics.

¹ Note that the Germans developed and deployed the first precision-guided weapons and used them to great effect, such as with their visual command-guided, air-to-ground antiship bombs. However, it was the U.S. that made the first production IR-guided bomb, the bolometer-based VB-6 Felix (Figure 3-4), but it was never used in combat because the war ended before that could happen.

First, Germany's development of lead salt photoconductive detectors, most importantly, PbS, led the world at the end of WWII. This leadership was not the result of a better understanding of semiconductor physics, but rather it was the product of laborious, empirical measurements coupled with equally laborious trial-and-error experimentation. (Thomas Edison's famous quote that "genius is 1% inspiration and 99% perspiration" is fitting.) Though the Germans had a significant early lead in photoconductor development, they were not very successful in equipping their forces with products of advanced photoconductor technology as compared, for instance, to their photoemissive technology. This situation may have been due to the fact that most of the progress came near the end of the war, and much of Germany's industrial base had been destroyed by Allied bombing by that time.²

The U.S., Germany, and Russia were all able to develop and exploit photoemissive detectors during WWII. All of the deployed systems were based on this NIR capability including night observation imaging systems, sniperscopes, and driver's aids. These devices were the most successful IR products in WWII. It can be said that they were not true IR sensors because they didn't respond to object self-emissions at room temperature. Nevertheless, while they arguably aren't the most tactically important devices today compared, for instance, to FLIRs, they are still among the most widely deployed devices in the world. Although by the end of WWII warfighters could covertly see at night with systems that used invisible, active illumination, these systems were still far from the goal of passive, fast-framing sensors that could see self-emissions from objects at room temperature.



Figure 3-4. U.S. VB-6 IR guided bomb (Source: USAF).

² British intelligence had uncovered German advances but did not appear to take advantage of them. That decision was probably at least partly due to their emphasis on radar development, which was an area in which both the U.S. and the British were ahead of the Germans.

CHAPTER 4. POST-WWII IR TECHNOLOGY

4.1 INTRODUCTION³

Post-WWII IR technology was characterized by foundation building and infrastructure development. It was heavily influenced by German detector discoveries and the spreading realization that IR technology offered unique advantages in warfare. The U.S. exploited much of Germany's knowledge after the war by offering refuge to their scientists and engineers. This exploitation led to the successful development of at least one major IR weapon system that gave the U.S. an initial advantage in the Cold War: the Navy's Sidewinder air-to-air missile that used a PbS detector. However, PbS was not the dominant detector material because of its limited spectral response and resulting inability to respond in either the MWIR or the LWIR bands. Therefore, new materials had to be developed, and a better understanding of semiconductor physics was needed.

In addition, the beginning of the Cold War led to a new impetus for national defense and greatly increased funding. Despite the many new developments, image-forming systems were still largely improved versions of WWII sniperscopes. It was not until the Vietnam War (discussed in Chapter 5) that passive, fast-framing imaging systems capable of viewing object self-emissions were developed. Nevertheless, a key technical base was developed including cooled indium antimonide (InSb) detectors for the MWIR band that led to a scanning IRST. Additional important developments included LWIR band detectors made from mercury-doped germanium (Ge:Hg) and the later breakthrough discovery of the properties of mercury cadmium telluride (HgCdTe) detector material (referred to as "MCT" from here on). Thus, the foundation for fast-framing FLIRs was laid, but their invention came later.

The post-WWII period is notable for at least seven significant developments affecting IR technology:

- Increased investment in government laboratories and the industrial base.
- Improved radiometric standards.
- Better means to communicate knowledge and progress.
- Breakthroughs in detector development.
- Development of high-resolution IRST systems thus enabling capabilities that contributed to the FLIR technology base.
- Invention of down-looking line scan mappers that enabled viewing mid-wave and long-wave images.
- Development of performance metrics for imaging systems.

The development of cryocoolers, Dewars capable of 77 K and 28 K operation, and integrated circuits was also significant, but those developments are beyond the scope of this book. This history will focus on the former seven listed developments and each is described in the discussion that follows.

4.2 INCREASED INVESTMENT IN GOVERNMENT LABORATORIES AND THE INDUSTRIAL BASE

New expertise in IR technology developed quickly in the post-war years. Greater funding resulted from the emergence of the post-war Soviet Union as a major threat to the U.S. and its allies. More government laboratories were formed, but even more reliance was placed on private contractors and university laboratories. The government and private laboratories in the first decades of the century were joined by a new operational model in scale and practice. The new model consisted of funding through research and development contracts that proliferated in proportion to increases in military expenditures. Driven by greater funding, many contractors, universities, and government laboratories developed greater expertise.

³ Sources used in this chapter include extensively edited and merged excerpts from Robert Sendall [19], Steve Jost [20], and Kirby Taylor [21] in addition to the many references cited throughout the body of the text.

All three branches of the armed services had organizations involved in IR technology development. For the Air Force, much of the development was conducted in the Avionics Laboratory at Wright-Patterson Air Force Base (AFB). In the Navy, the Office of Naval Research (ONR) and the Naval Research Laboratory (NRL) took the lead. In the Army, the Army Corps of Engineers set up the Engineer Research and Development Laboratories (ERDL) in 1954 [22], where the Research and Photometric section began developing personalized night vision equipment for individual soldiers. This unit became the Night Vision Laboratory (NVL) and was later renamed the Night Vision and Electronic Sensors Directorate (NVESD), most recently reporting to the U.S. Army Research, Development, and Engineering Command (RDECOM) and Communications-Electronics Research, Development and Engineering Center (CERDEC) [23]. ERDL assumed much of the responsibility for Army IR technology development. However, their early emphasis was on NIR imagers that amplified night ambient light such as image intensifiers and low light level televisions (LLLTVs), but it also included active laser pulse-gated TVs. Army emphasis later changed to the more promising passive systems that could see self-emissions. By the mid-1970s, given the Army's large procurement budget for outfitting its many ground and air vehicles with night vision equipment, the NVL developed considerable expertise and arguably became the lead government laboratory influencing the direction of IR technology.

Still, most of the actual IR development was accomplished by private industry. The major detector firms by the late 1960s were the Santa Barbara Research Center (SBRC) (a subsidiary of Hughes Aircraft Corporation [HAC]), Honeywell, and Texas Instruments (TI). Thus, apart from the University of Michigan, itself a major beneficiary of military contracts, and Syracuse University, the bulk of IR research was being conducted by private firms. Previously centered in universities, IR technology had been redirected by the Cold War to become a specialty outside the mainstream of academic science, much like photometry.

4.3 IMPROVED RADIOMETRIC STANDARDS

New infrastructure was needed to address the problem of radiometric references and measurement standards. The very notion of a reference standard was problematic due to the complex nature of real-world object emissions. Similarly, the nature of aircraft as sources of light is complex. The leading surfaces of a jet airplane or missile are heated by aerodynamic friction, and they emit IR light similar to a blackbody source. Jet and rocket nozzles are much hotter than the surfaces of jet airplanes and missiles, and the exhaust gases themselves are often a combination of blackbody radiation and emission lines (strong radiation of isolated wavelengths due to chemical species in the burning fuel). Indeed, the spectral distribution of radiation could serve as an accurate and unique signature of the airborne body thus identifying its type. In such circumstances, the comparison of instruments was difficult. "Traceability of instrument performance to the National Bureau of Standards is more and more a real question," noted W. Wolfe, editor of the *Handbook of Military IR Technology* [24]. The calibration of the detection equipment was therefore inexact, involving a combination of crude laboratory comparisons, theoretical estimates, and expensive field trials.

The very form of the radiometry units also changed to suit new circumstances. The new light sources of interest were not static. That is, aircraft, rockets, soldiers, and tanks change distance, angle, orientation, and apparent shape. Consequently, the old units of radiometry ceased to be adequate. Why should investigators be concerned with the total power (the *radiant flux*, in watts) emitted by a light source or the power emitted from its surface (the *radiant emittance* or *exitance*, watts/square meter [W/m^2]), when its size and even distance might be unknown? When sources became uncooperative *targets*, new measurement philosophies and units gained relevance. All measurements were based on what could be measured by the detector rather than on how the light source could be manipulated. In a given band, the power density falling on the detector (*irradiance*, W/m^2), the power radiated into a solid angle (*radiant intensity*, watts per

steradian [W/sr]) and, given the luxury of knowledge of the target size, the power radiated into a solid angle per area of the source (radiance, W/sr m²) became the new values of interest.

4.4 BETTER COMMUNICATION OF IR RESEARCH

4.4.1 Conferences

One of the most needed improvements in the IR research and development infrastructure was the creation of formal avenues of information dissemination. Government-sponsored bodies organized new, more formal conferences that replaced informal, word-of-mouth communications at limited attendance meetings. Lovell [14] reported that the ONR Branch Office in Pasadena, California, began sponsoring the Joint-Service Classified Symposia in 1949, which may have been the first of its kind. However, the first formal conference, according to Biberman [25] was the government-industry cosponsored Guided Missile IR Conference formed in 1952. Its focus was air-to-air missiles because that was the most promising application at that time. In 1956 it was expanded in scope to become the IR Information Symposium (IRIS). IRIS was run by the IR Information and Analysis (IRIA) Center as part of the University of Michigan and was sponsored by the ONR, but policy was determined by an executive committee, which included equal representation from the three military branches and several representatives from the defense contractor community. By 1961, the IRIA charter included collection and dissemination of information from the large number of IR development projects ongoing nationwide. Starting with a small group of researchers in the early 1950s, IR meetings grew to between 500 and 1,000 participants by 1965, including attendance at all separate, "specialty group" topical meetings. Specialty group meetings would be held on topics of interest to development engineers and scientists in such specialized areas as detectors, passive sensors, active systems, target backgrounds and discrimination, etc. Much later in 2004, IRIA became the Military Sensing Information Analysis Center (SENSIAC), one of multiple "IACs"

formed by the Defense Technical Information Center (DTIC) chartered to collect and analyze specialized information to support various military technology development thrusts. At that same time, the IRIS meetings were renamed to become the Military Sensing Symposia (MSS).

As an active participant and detector specialist who attended many MSS meetings over his career, Steve Jost (BAE), had the following perspective on the value of the symposia [20]:

All technologists benefit and grow from interaction with others in the same field, and the detector community was no exception. Due to the huge military advantage in "owning the night," much of the technology beyond basic thermodynamics and semiconductor physics was "secret." The DOD recognized the importance of such technical interactions and initiated a series of secret level meetings where the non-proprietary aspects of the technology could be debated and discussed and so the IR Information Symposium (now Military Sensing Symposium) was born.

These meetings provided a classified venue to share results of sensor development or production and get the government's perspective on "market" trends. While the formal presentations and discussions were instrumental for keeping abreast of industry and government developments, it was the informal interactions and recruiting activities that promoted collaboration, competition, and "technology transfer." The interaction [among] systems engineers, the user community, and detector technologists undoubtedly had a positive impact on the sensor technology employed by U.S. forces.

Although the classified proceedings of the meeting could not be made openly available, they were published for industry and government

individuals with a "need to know." This provided an important historical perspective of the technology and documented the thinking that led the community to embrace a particular approach [20].

With the growth of IR technology, the new catch-all subject of EO was becoming a more useful description. The *Handbook of Military IR Technology* [24] mirrored this new subject by acknowledging publications mainly of the IEEE (*Institute of Electrical and Electronics Engineers*); its predecessor, the IRE (*Proc. Inst. of Radio Engineers*); the Optical Society of America, including the *Journal of the Optical Society of America (JOSA)* and *Applied Optics (AO)*; and in Britain, the Institute of Physics (*J. Sci. Instr. and Physics in Technology*). The editors categorized IR detectors as a subcategory of modern optics entwined with the contemporary field of solid-state physics.

The Society of Photo-Optical Instrumentation Engineers (SPIE, renamed The International Society for Optical Engineering in the 1980s), a small organization bringing together technologists primarily in the photographic and motion-picture industries in the post-war years, was transformed by an influx of researchers benefitting from military contracts. The initial connection was the need for specialized cameras and tracking devices to monitor missile launches. Gradually, however, these new EO engineers, versed in mechanical, optical, and electronic design to varying degrees, began to work with IR systems. The military component was so significant that some SPIE meetings were restricted to American citizens during the 1970s and 1980s.

4.4.2 The IR Handbook and Other Publications

In the early 1960s, the large number of firms and technologists connected with IR technology demanded wider distribution of information to include openly available books. Civilian applications were also sufficiently widespread to promote popular articles and texts. The major source of information, however, was the *Handbook of Military IR Technology* [24] sponsored by the ONR, contracted by the Advanced Research Projects Agency (ARPA), now the Defense Advanced

Research Projects Agency (DARPA), written by the University of Michigan (W. Wolfe, ed.) and published in 1965 by the NRL. Given the military background of this work, it is not surprising that many sources of information were connected with target analysis. Among sources of information and organizations that contributed to this publication included the Ballistic Missile Radiation Analysis Center, the Target and Backgrounds Signature Analysis Center, and the Background Analysis Center, which were all at the Institute of Science and Technology at the University of Michigan. Other contributors to the handbook were the Remote Areas Conflict Information Center (RACIC) at the Battelle Memorial Institute in Columbus, Ohio and the Counterinsurgency Information Analysis Center (CINFAC) at American University in Washington, D.C. Radiometry, the central subject of the book, was extended to the meteorology of clouds, properties of the atmosphere, vegetation and ground covers, tracking system design, linear systems engineering, thermal coatings, and optical materials.

This compendium was updated in 1978, as the ostensibly civilian *IR Handbook* [26] (Figure 4-1). In this version, the military applications of radiometry were de-emphasized. The chapters on "Targets and Backgrounds" were subsumed into "Artificial Sources and Natural Sources." However, IRA remained the sponsor. Similar research and development programs were instituted in the Soviet Union, and produced similar technical compendia, both overtly and covertly military in origin.

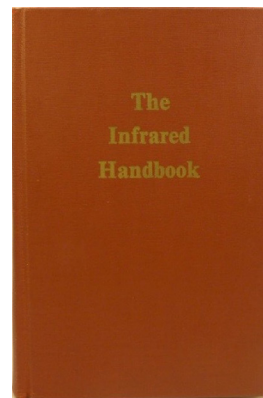

Figure 4-1. 1978 IR Handbook (Source: SENSICAC).

The *IR Handbook* was updated again in 1993 and became an eight-volume set called *The IR & Electro Optical Systems Handbook* [27]. Several other books were written that significantly increased the distribution of IR technology and practice. One of the first, *Elements of IR Technology*, was written by Paul Kruse [28] in 1962 at Honeywell. However, *IR Systems Engineering*, written by Richard Hudson [22] in 1969 at HAC, had the most impact. It not only became a standard educational tool in the U.S. but was widely read in the Soviet Union as well [29], although the latter was probably not what the author had intended. This book, although written in 1969, is still relevant to modern IR systems, and that relevance is testimony to the knowledge, thoroughness, and expertise of the author.

4.5 BREAKTHROUGHS IN DETECTOR DEVELOPMENT

4.5.1 PbS Detectors

IR technology progress has always been paced by detector development progress. Early post-war detector availability was mostly limited to PbS because of the successful transfer of that technology from Germany. However, PbS was nominally only useful in the 1–3- μm band, and it was recognized just from blackbody radiation principles that the mid-wave 3–5- μm and long-wave 8–12- μm bands offered significant potential for improvement. For instance, radiation contrast peaks in the 8–12- μm band for room-temperature objects, so because sensitivity was at a premium, there was considerable motivation to exploit the advantage of that region. Missile seekers andIRSTs are more effective when they can sense jet engine plume emissions as well as aerodynamically heated skins for all aspect aircraft detection and tracking. So, they work best in the 3–5- μm band, at least at short ranges or high altitudes where there is less atmospheric attenuation of the plume signature. Besides sensitivity, both the 3–5 and the 8–12- μm bands, in general, offer a highly transmitting atmospheric window as well. The advantages of these bands motivated the development of detectors that responded to the longer wavelengths of the MWIR and LWIR.

4.5.2 InSb Detectors

Efforts to design betterIRSTs and missile seekers led to the development of cooled photovoltaic InSb. This development finally resulted in MWIR detectors with sensitivity limited only by the shot noise in background flux. When cooled, lead selenide (PbSe) offers response that extends into the mid-wave band, and cooling reduces internal noise due to dark current. However, InSb, when cooled to 77 K, performs far better than PbSe. Moreover, InSb could be prepared in highly pure, single-crystal form with conventional growth techniques. This advantage eventually made it producible and affordable, but it took a great deal of trial and error. The Hughes Phoenix Search and Track system for the Navy F-14, circa 1965, was the first significant program using SBRC's InSb crystal detectors. The program started using an eight-element photoconductive InSb array developed by SBRC and Honeywell Minneapolis. The early units were delineated by sandblasting, and both suppliers experienced a great deal of difficulty with stability and other problems. SBRC finally developed satisfactory InSb detectors after a change to the photovoltaic mode, and they ultimately became widely used in modern FLIRs.

4.5.3 Ge:Hg Detectors

The discovery of the transistor in 1947 also provided important impetus for advances in detectors. For instance, transistor research stimulated better growth and purification techniques in semiconductors. Silicon and germanium (Ge) were favored semiconductor materials, so methods for impurity insertion became available for these materials first. It was soon recognized that doping Ge with mercury (Hg) as well as some other materials would provide response in the LWIR band [12]. This discovery eventually led Henry Levinstein's group at Syracuse University with Air Force funding, and eventually others, to fabricate Ge:Hg detectors that responded in the LWIR band. However, these detectors needed to be cooled to about 28 K and thus needed large, heavy, and power-hungry, two stage cryocoolers, but they significantly improved performance. Much later in 1969, the Air Force

launched the first real production FLIR program when they procured Ge:Hg detector-based FLIRs for B52 bombers.

4.5.4 HgCdTe (MCT) Detectors

In 1959, a major breakthrough occurred when W. D. Lawson's group at the U.K. Royal Radar Establishment (RRE) [30] discovered both photoconductive and photovoltaic response in the ternary alloy mercury cadmium telluride (HgCdTe, or MCT). Although this discovery was a breakthrough, the group was unsuccessful in its attempts to make practical detectors from MCT. However, shortly thereafter in 1962, Paul Kruse's group [31] at the Honeywell Research Center in Minneapolis developed a crystal growth technique for this alloy in the U.S. The narrow band gap and variable ratio of its components allowed the material to be tailored to respond over a wide spectrum from the near IR to beyond 12 μm . Moreover, the material was intrinsic with attendant high quantum efficiency in thin detectors. It had a low dielectric constant, which lowered capacitance to provide rapid temporal response and the wide bandwidths needed for fast-framing FLIRs. Most importantly, it provided background-limited noise levels at the much higher temperature of 77 K. The latter characteristic allowed using much smaller and more practical cryo-coolers and Dewars with attendant dramatic reduction in system size, weight, power, and cost (SWaP-C). Development of MCT detectors ultimately enabled the mass production of first-generation FLIRs. However, MCT fabrication was still difficult, and widespread use of MCT detectors did not occur until the early 1970s.

The importance of Paul Kruse's HgCdTe (or MCT) discoveries at the Honeywell Research Center in Minneapolis cannot be overestimated. Kruse was a productive scientist and inventor. For instance, he was credited much later for inventing microbolometer focal plane arrays and they, one might argue, were destined to have an equally large impact on IR technology. Fortunately, we have the benefit of transcriptions from Marion Reine's taped interview with Kruse in 1980. It is so insightful and revealing of the effort and luck required to fabricate MCT detectors that the interview is

reproduced as Appendix A in this report. What is not widely known about Lawson's MCT discovery is that when he and his colleagues in the U.K. RRE did not immediately succeed in making viable detectors, they were forced to drop the effort for many years only to pick it up much later after hearing of Honeywell's success. According to U.K. researcher T. Elliott [32], the RRE was required to drop its MCT research shortly after Lawson's breakthrough in order to devote those resources to developing mid-wave InSb detectors needed for missile seekers because there was no operational requirement for LWIR detectors. Paul Kruse and his group, on the other hand, were able to fabricate reproducible MCT detectors by about 1964 and, after initial papers [31, 33] in the open literature, published most of their results in classified IRIS proceedings. While they protected their proprietary techniques, their success inspired others, such as TI, HAC, and later the British, French, and Russians, to develop their own techniques, and the technology soon spread.

Robert Talley [33], president of SBRC during that period, made some observations that illustrate the payoffs and challenges that all the competing MCT detector developers faced:

SBRC got into HgCdTe development in a serious way. It was clear that this material was going to be the key long wavelength detector material of the future.... It required many years of experimentation to develop the necessary techniques to achieve high quality material. Although each laboratory bought the purest starting materials, the resulting purity was not adequate. SBRC's approach to purification and crystal growth was to zone-refine the compounded HgCdTe many times. By mid-period some detectors showed performance equivalent to those at Honeywell, but there were serious problems with yield, stability, electrical contacting, and other related issues. By the end of this period, SBRC still lagged behind Honeywell.

SBRC eventually did succeed in making high-quality, producible MCT detectors. In fact, HAC, through their SBRC subsidiary, ended up being one of the largest suppliers of first-generation common module detector arrays.

Like many breakthroughs, successful operational MCT detectors were the result of an accident combined with the astute recognition of the by-product of that accident. In this case Kruse reported that, because of a failure in the furnace used to grow MCT crystals, the molten ingot source material accidentally cooled instead of remaining in the molten state as the crystal grew. The result was unintentional annealing of the MCT compound. That annealed boule was set aside until months later when an astute technician, Bernice Johnson, noticed that it showed traces of the same pinkish color that previously characterized the best performing MCT material. So, they made detectors out of it and discovered to their surprise that it showed greatly increased detectivity. It was the breakthrough that showed the way to repeatable fabrication of highly sensitive, long-wave MCT detectors. The story also shows how much successful fabrication depended on experimentation instead of in-depth material understanding. It is also reminiscent of how the Germans achieved success with PbS and PbSe detectors two decades earlier: not with great understanding of material science, but with persistent and time-consuming experimentation and measurement until success was achieved.

Adoption of MCT for development was not only lucky from the standpoint that no one knew how to fabricate usable detectors, even given that it had promising theoretical properties, but rather MCT had many drawbacks that made working with it very daunting as it is to this day. For instance, Hg vapor pressure can be over 20 atmospheres when heated in crystal growth processes. That pressure caused many laboratory explosions that not only demolished expensive crystal growth equipment but made whole laboratories unusable due to dangerous contamination by toxic Hg. Also, MCT is both soft and brittle, so cutting and polishing it during fabrication of crystals into detector elements could easily damage a detector after many hours of labor were expended,

thus making fabrication expensive. These drawbacks caused many to doubt its viability as a detector candidate even after its very desirable photosensor properties were understood, and MCT's viability is still questioned. Clearly MCT became a breakthrough material because it offered ideal sensitivity in the LWIR band at 77 K temperature, but it still would not have emerged when it did if it were not for luck, knowledge, and persistence together with years of government funding and corporate management's support of their research laboratories.

4.6 DEVELOPMENT OF IRST SYSTEMS (ADAPTED FROM ROBERT SENDALL'S SENSIAC REPORTS [19])

The development of IRSTs helped to advance a baseline of enabling technology that soon contributed to the emergence of FLIRs as well. As previously stated, IRST sets have been used in various forms since WWII, even though they were not called that before about 1960. The IRST is a passive sensor that uses heat emitted by the target to generate data for the weapon system of an aircraft or other platforms such as ships or anti-aircraft batteries. Passive operation of the IRST has the advantage of concealment. In addition, it can be designed with an auxiliary narrow field of view (FOV) to provide high-resolution imaging for long-range visual identification when the image is presented on a display [19].

Using sensors that detect heat in searching for targets from combat aircraft is as old as the use of these sensors for missile guidance. The first models exhibited limited performance in that a target image was not formed. Instead they relied on nonimaging techniques such as a scanning reticle or a scanned cross array in a cruciform configuration to determine a target's position without forming a displayed image. Other early IRST designs would raster scan the scene with detector line arrays to show target position by means of symbology positioned on a head-up display. These early versions had difficulty with high false-alarm rates due to low resolution and clutter such as sunlit cloud edges and ground objects. Much like FLIRs, current IRSTs show high-resolution imagery on a monitor, so the operators can see the objects to help

reduce false alarms. In that, there is little difference in the way they operate compared to a FLIR.

U.S. Air Force and Navy aircraft of the 1950s and 1960s, such as the F-101B Voodoo, F-104 Starfighter, F 106 Delta Dart, F-8 Crusader, and F-4B Phantom, were equipped with these early sensors. Air Force interceptors carried nose-mounted, nitrogen-cooled, lead selenide (PbSe) cross-arrayIRST sets to detect high flying Russian bombers, such as the Bear and Bison. This application exploited the strength ofIRSTs, which is its ability to detect and track a target passively, and thus, undetectably. Such an attribute is considered a major asset in air defense operations because a large bomber typically carries a radar warning receiver and a powerful onboard jammer so it can receive timely warning of impending attack and defend itself by jamming the interceptor. This strategy was also adopted by the U.S. Navy, which equipped its F-4B fighters with chin-mounted AAA-4IRST sensors. Moreover, theIRST was also incorporated into the Navy Vought F-8 Crusader (F-8E) variant, shown in Figure 4-2, where it was used to cue targets for AIM-9B Sidewinder seekers.



Figure 4-2. Vought Crusader F-8E variant (Source: U.S. Navy).

Later, when airborne Doppler radar became feasible,IRSTs and radars were integrated together to provide the advantages ofIRST covertness with radar's low false-alarm rate, long range, and fire-control capabilities. The HAC AN/ASG-18 prototype airborne radar/IRST fire-control system was the first U.S. pulse-Doppler radar system with look-down/shoot-down capability. Pulse-Doppler radars have an advantage over passiveIRSTs in detecting closing aircraft against ground clutter because Doppler signal processing effectively removes stationary objects. The radar range of the AN/ASG-18 was estimated to be between 200 and 300 miles with

reliable detection of bomber-sized targets at 100 miles. Installation of the AN/ASG 18 was a massive undertaking since it weighed 2,000 lb and took up most of the aircraft's nose. The system was planned for use with the HAC AIM-47 Falcon radar guided missile, which also had a range of about 100 miles. It was never produced but became the forerunner of the successful Phoenix AIM-54 missile and fire-control system deployed on the Navy's F-14 Tomcat fighter. While the later PhoenixIRST had a greatly improved mid-wave InSb detector array, it was eventually removed in favor of just using the radar due, in part, to theIRST's short range, lack of a displayed target image, and resulting high false-alarm rate. Much later, however, a new generation of LWIR detectors enabled Sanders/BAE to design a greatly improved F-14DIRST that was effective at long ranges and widely deployed.

4.7 DEVELOPMENT OF LINE SCAN MAPPERS (ADAPTED FROM KIRBY TAYLOR [21])

Line scan mapper development was the last step leading up to the emergence of FLIRs. Line scan mappers were the first IR sensors that provided the capability to view images formed from room temperature object self-emissions. (AlthoughIRSTs predated mappers, earlyIRST versions did not present images to operators, while much later versions did. Moreover, earlyIRSTs generally required higher object temperatures.) Early IR mappers used a single detector that was swiped one scan line at a time across the ground by a scan mirror. The output was fed to a glow bulb illuminating a spot on a photographic film carriage (Figure 4-3 [left]) [34, 35]. The forward motion of the aircraft resulted in successive scan lines being generated on a film strip fed by a reel that was synchronized to the speed of the aircraft as illustrated in Figure 4-3 (right). These systems were very successful at reconnaissance but not at providing direct fire support. Nevertheless, they showed the utility of IR imaging and soon led to directable, real time imaging systems, now called FLIRs, as described in Chapter 5.

The archival literature does not provide much information about the origins of line scanners except that several U.S.

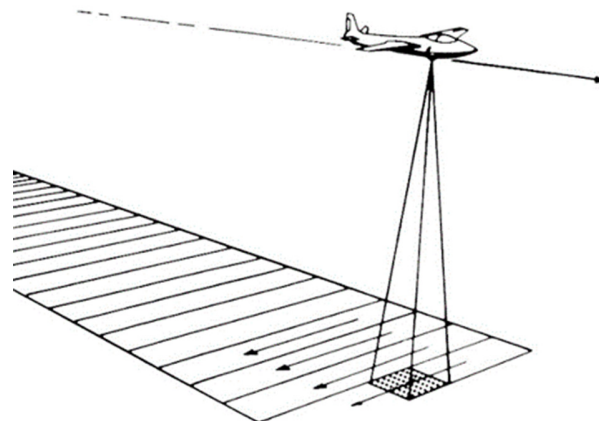
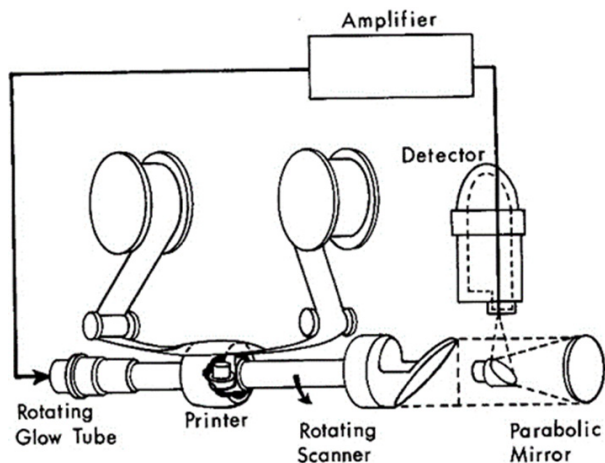

Figure 4-3. Illustrations of an IR mapper [34, 35]. An image scanned by a rotating mirror is transferred to film via a synchronously scanning glow tube modulated by the IR detector output (left). Forward motion of the aircraft adds the second dimension to the raster scan (right) (Source: U.S. Air Force).

companies eventually made them. In 1947 Alexander Nyman applied for a patent titled "Stabilized Automatic Mapper" [36], but it wasn't granted until 1969 perhaps because of security issues. His patent disclosed a system that used gyroscopic stabilization and an oscillating optical system which could be used in an airplane to map the ground. Nyman worked for several employers during his career, including Westinghouse, but the patent is only in his name.

TI was an early pioneer in line scan mapper development. According to the TI website [36], company management saw the potential of IR technology in the mid-1950s, which led to the acquisition of the William I. Mann Company. Mann was a California EO expert whose company inventory included silicon detectors, missile guidance heads, fire control sights, and light sources. Mann then became general manager of the new TI Optics Division whose core was formed from his company. To complement TI's IR aspirations, their Semiconductor Research and Development Labs sought and won contract funding from many government agencies. That funding led to a major breakthrough when TI was able to integrate a detector and preamplifier on the same chip. At the same time, TI was pioneering long-wavelength (8–14 μm) Ge:Hg detectors. These advanced technologies enabled TI to win an Army contract in 1957 to develop a wide-angle IR mapper, the UAS-5, which used a single-axis "Kennedy" scanner to im-

age the ground below the airplane from horizon to horizon. The UAS-5 marked the beginning of the IR systems business for TI and led, in 1961, to the production of the AAS-18 line scanner. That line scanner was mounted on the RF-4C aircraft and was used to map infiltration routes in Vietnam. Figure 4-4 shows an image formed by the TI UAS-5 line scan mapper [36].

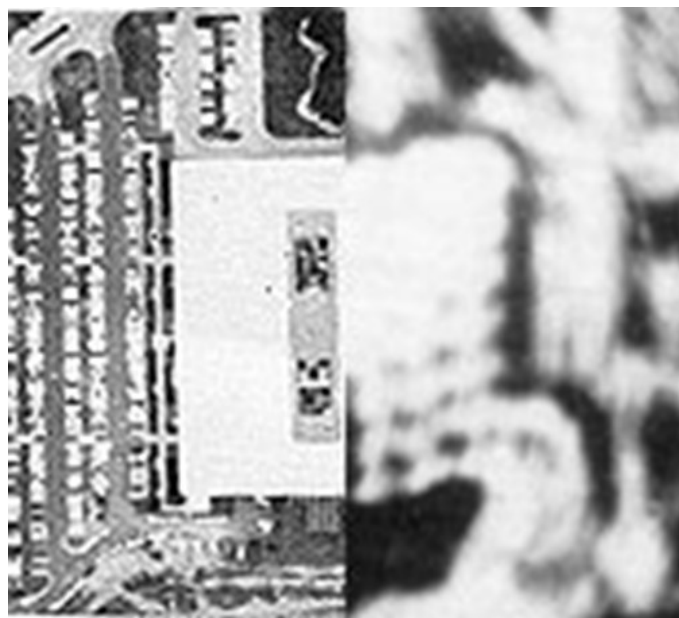

Figure 4-4. A visible-band aerial photograph of the TI plant (left) and the corresponding mapper image (right) (Source: TI).

According to Kirby Taylor, the first version of the UAS-5 used a single-cell InSb detector cooled by LN2 to 77 K and operated in the 3–5 μm wavelength band. Then, a longer wavelength detector, the Ge:Hg, became available, and it was easily introduced into the sensor from the standpoint of the optics due to the fact that all the optics were reflective. However, the Ge:Hg had to be cooled to 25 K or less. Since there were no practical mechanical cryocoolers available that worked at that temperature, liquid helium had to be used. Initially the problem was solved by storing the helium in a "double" Dewar designed for an inner chamber of helium surrounded by a vacuum, surrounded by LN2, surrounded by a vacuum. This important component was developed by a company named Linde. The combination of LN2 in the outer Dewar and liquid helium in the inner Dewar worked very well and produced the first LWIR imagery in the 8–14 μm band.

When the line scan mapper was deployed in war zones, mostly in Vietnam, providing the liquid helium for Ge:Hg cooling was difficult. LN2 was not much of a problem since most bases have liquid oxygen plants making LN2 as a by-product. Helium posed a much larger problem. First, liquid helium is dangerous, especially during air transport. In addition, it "boils" off rapidly at altitude, and so a long-distance supply flight yields small quantities at the destination. The same physics made problems for the Linde Dewar in operational flights. The Dewar and the mapper could only operate for approximately an hour.

The pressure to develop mechanical cryogenic coolers suitable for the deployed systems was intense. The North American Phillips Company provided operational units beginning in the early 1960s. This basic design went forward to other production systems such as the AN/AAS-18 for the RF-4C aircraft and was used later with the first prototype FLIRs. The technology developed to enable these mapping systems to function for longer periods proved to be critical during the development of FLIR systems.

4.8 DEVELOPMENT OF PERFORMANCE METRICS

4.8.1 Bar Target Equivalency Criteria

Arguably, one of the most important advancements that facilitated the emergence of FLIR technology, bar target equivalency criteria, was not originally developed for FLIRs but drove the design of early devices and even still had an impact on FLIRs as recent as 2016 and likely will going forward as well. That development was the "epiphany" Johnny Johnson [37] of the U.S. Army NVL, now NVESD, had when he recognized that bar target test patterns could be used to replace actual target images in what he called "bar target equivalency criteria." He set up an observer test in which test subjects were shown actual target images filtered to varying degrees of discernibility. Johnson then measured the level of resolution required for the observers to accomplish various target acquisition tasks from the lowest level to the most difficult. The tasks ranged from detection, to orientation, to recognition, and finally to the most difficult, identification. He then substituted spatial frequency bar target patterns for the real image to measure the level of resolution the observers needed for each acquisition task and probability level. Figure 4-5 illustrates the method used and the results obtained.

Johnson used this method for image intensifier-based night vision devices, and it soon was incorporated into bar target equivalency criteria for LLLTVs and FLIRs as well. The criteria enabled imaging device performance to be measured in terms of spatial frequency resolution, which then could be compared to predicted device performance as obtained using linear systems theory. Otto Schade [38] had earlier suggested that this theory could be used to perform TV analysis while working at RCA in the early days of TV development. Schade made the astute observation that a temporal frequency, i.e., a sinusoidal voltage pattern varying in time, was analogous to a spatial frequency. In fact, when a TV pickup tube scans a read beam across an image of a sinusoidally varying intensity pattern, the output is a temporal frequency that depends on the scan beam velocity and the spatial dimension of the sinusoidal pattern. With those

IMAGE TRANSFORMATION

(BAR TARGET EQUIVALENCY CRITERIA)

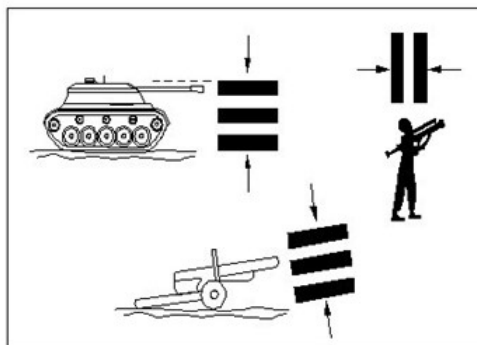

TARGET	REQUIRED RESOLUTION (LINE PAIRS) PER MINIMUM DIMENSION*				
	BROADSIDE VIEW	DETECTION	ORIENTATION	RECOGNITION	IDENTIFICATION
TRUCK		.90	1.25	4.5	8.0
M-48 TANK		.75	1.2	3.5	7.0
STALIN TANK		.75	1.2	3.3	6.0
CENTURION TANK		.75	1.2	3.5	6.0
HALF-TRACK		1.0	1.50	4.0	5.0
JEEP		1.2	1.50	4.5	5.5
COMMAND CAR		1.2	1.5	4.3	5.5
SOLDIER (STANDING)		1.5	1.8	3.8	8.0
105 HOWITZER		1.0	1.5	4.8	6.0
AVERAGE		1.0 ± .25	1.4 ± .35	4.0 ± .8	6.4 ± 1.5

Figure 4-5. Johnson's Bar Target Equivalency Criteria determined resolution requirements for various target acquisition tasks [37] (Source: U.S. Army).

equivalents in place, Schade recognized that the same linear systems theory, including the powerful Transfer Function, which characterized electrical system temporal frequency response, was just as applicable to characterizing optical and EO image-forming system response. This discovery generated the equivalent transfer function metric, later called the Modulation Transfer Function (or MTF). The MTF was used by both optical and EO engineers to quantify the resolution of their respective systems. Since EO systems consist of both optics and electronics, MTF proved to be a convenient metric for quantifying the resolution performance of the combined systems.

Schade's and Johnson's work not only helped to base FLIR design and performance analysis on sound engineering principles, but it also provided the measurement-based criteria they needed to meet for evaluation and comparison between approaches. Fred Rosell [39] at Westinghouse ex-

tended the basic theoretical and psychophysical framework when he studied the effects of system noise on observer performance again using TV systems. Though the work of these three pioneers provided a very important foundation, it was still not directly applicable to FLIRs but Bob Sendall at HAC developed a similar framework for FLIRs and later worked with Rosell [40] to merge their modeling and empirical performance data so they applied to both FLIRs and TVs in a common methodology. In the case of FLIRs, Sendall developed the Minimum Resolvable Temperature (MRT) metric, which combined the effects of both noise and resolution on performance as seen by an observer viewing imagery on a FLIR display. This fundamental performance analysis approach and criteria allowed FLIRs to be designed to meet specific user performance objectives and allowed government procurement officials to rigorously compare competing designs. James Ratches [41] at NVL later incorporated the methodology in a FORTRAN computer code that

became the first of many NVL/NVESD models that were widely disseminated to the IR community as a design tool. As of 2016, these basic criteria and models were still being used to design current FLIRs. Both the criteria and the models have been continuously refined to incorporate the most recent measurement data and new modeling insights as will be discussed in Chapter 9.4. Ultimately, their work developed into a new engineering discipline: EO systems engineering.

4.9 SUMMARY AND CONCLUSIONS

Immediately following WWII and leading up to the Vietnam War, there was substantial development of IR infrastructure and enabling technology. Key contributions included better communication of IR research, better detectors, new scanning system technology, and new performance metrics. However, a viable, fast-framing FLIR was not produced during this period; that achievement occurred during the Vietnam War as is described in Chapter 5.

CHAPTER 5. VIETNAM-ERA FLIR DEVELOPMENT

5.1 INTRODUCTION

During the Vietnam War era (1964–1973), the first practical, fast-framing FLIRs were developed. Many companies and government organizations contributed to their development. However, two companies played the largest role: HAC with its subsidiary SBRC (became RVS) and TI (portions of TI later became DRS). Others such as Aerojet General, Honeywell (to become BAE), and AVCO (became CE, then L-3) were competitors and made key contributions but had lesser overall roles at the system level during this era. The recollections in this chapter of key contributors Robert Sendal [19] (HAC) and Kirby Taylor [21] (TI) provide valuable and insightful observations about the struggles to perfect FLIR technology and how they overcame adversity. These observations can help future developers understand what it takes to succeed in a corporate/government/war-time procurement environment.

Important contributions to both FLIR development and FLIR history documentation were also made by J. Michael Lloyd at Honeywell and Lucien M. Biberman at the Institute for Defense Analysis (IDA). According to Lloyd [42], fast-framing thermal imagers were not feasible before the late 1950s because detector bandwidths had to be limited to a few hundred hertz due to poor detector time response. However, detector time constants got shorter with the emergence of cooled InSb and Ge:Hg, which combined with their mid- and long-wavelength spectral response, enabled strip mappers to become practical. He reported that the first LWIR FLIR was built in 1956 during the Korean War at the University of Chicago, with Air Force support, by modifying an AN/AAS-3 strip mapper that was designated the XA-1. It was made by adding a nodding elevation mirror to the existing horizontal scanner. Development was not pursued when the war ended, since there was no longer a pressing need.

Lloyd also reported that the Army developed one of the first FLIRs in 1960, when it funded Perkin-Elmer Corporation to build a ground-based FLIR. It reportedly used two rotating, refractive prisms, which performed a spiral scan of a single-element InSb detector over a 5° diameter circular FOV with a 1-milliradian instantaneous FOV (IFOV). The FLIR had a 5-Hz frame rate and an approximate 1.0 °C sensitivity. The flicker problem caused by such a slow frame rate was managed by using a long persistence phosphor cathode ray tube (CRT) display.

However, the Air Force Avionics Laboratory (AFAL) at Wright-Patterson AFB in Dayton, Ohio had the most influence of the government agencies in this era for two reasons. First, the Air Force needed strategic bombers to be equipped with FLIRs during the Cold War for low-altitude night navigation to avoid radar detection and for nuclear blast blindness protection when flying into the Soviet Union. Second, the Vietnam War began and the Air Force mission in Vietnam involved heavy roles in surveillance and interdiction. Those roles led them to have the earliest need to develop FLIR technology. Captain James Krause took the initiative to promote FLIR technology development and, as a result, not only became the Air Force's lead combat FLIR user but was very influential in the IR community. His feedback and design suggestions from a user standpoint, including his many presentations at IRIS/MSS meetings, had a major impact on the direction of FLIR development and use.

In addition to the Air Force's early pressing needs, both Navy and Army agencies had urgent needs and were involved in FLIR development as well. For instance, the Navy at China Lake experimented with FLIRs for P2A and RA-5 surveillance aircraft, and the Army explored them for use on their OV-10 Mohawk battlefield support aircraft. Both the Navy and the Army embraced FLIR technology and later became major sources of development and funding.

The role of Lucien Biberman at IDA was central in early FLIR development. IDA is a quasi-governmental, nonprofit Feder-

ally Funded Research & Development Center (FFRDC) created in 1956 to provide scientific and technical expertise to the Department of Defense (DoD). Biberman was widely respected for his role in creating the highly successful Sidewinder missile and for his technical savvy. He was always ready to voice his opinions at both formal and informal meetings if he thought programs were going in the wrong direction, even at the risk of offending powerful program interests. Biberman was puzzled by the performance disparity among early FLIRs and forced flight tests to compare competing systems. When the disparate results could not be explained, he realized that critical design parameters such as noise equivalent temperature (NET), frame rate, and apparent display size were not understood and were potentially not even all inclusive. He headed a committee of government and industry experts to define a performance model that would guide design specifications for future systems.

The urgent need for night viewing in Vietnam incentivized the military and defense companies to rapidly develop IR technology. HAC and TI were early competitors, and each took a different approach. In the end, TI equipment played the largest role and led to the development of the first-generation Common Module ("Mod") FLIR after the war. TI FLIRs used a more direct and simpler optomechanical design than HAC FLIRs, which minimized the need for still nascent multiplexing electronics. At first they used modified CRTs for display, but eventually progressed to simple, standard TV cameras to view and convert parallel output channels for serial display on standard monitors. HAC FLIRs were more complex and more difficult to build. They incorporated special electronics to implement detector-staggered spacing for cold shielding that required unique output multiplexing and time delay to register the resulting output for image display. However, the output was still not standard TV compatible, so it required a special nonstandard CRT display. The TI approach was more producible in this early era, but many attributes of the HAC multiplexer design were eventually incorporated into postwar designs and second generation (GEN2) FLIRs. HAC, under the leadership of Robert Sendall,

also led the way in the development of performance metrics, which were instrumental in optimizing system performance by quantifying the effects of both the system design parameters and the observer viewing the displayed image. All of this technological improvement would have happened eventually, but the incentives of the Vietnam War accelerated it during this era.

5.2 VIETNAM WAR IR IMAGING PROBLEMS AND SOLUTIONS

IR systems were extremely important during the Vietnam War, which involved jungle warfare against an elusive, often well concealed, enemy who preferred night operations. This highlighted the importance of IR systems. Airborne, down-looking line scanners, initially mounted in C-47 transport aircraft, were the first IR systems in theater. As described in Section 4.2, these systems scanned a single, LN₂-cooled, InSb photodiode detector back and forth across the flight path using the detector output to drive a miniature arc lamp that exposed a strip of photographic film. The film was developed after the aircraft returned to base and was examined by image analysts for signs of enemy activity. This method proved to be quite unsatisfactory (except for certain fixed targets), since the time delay between flyover and subsequent attack by strike aircraft was 4–6 hr. In spite of this drawback, over 1,000 line scanner systems were deployed on RF4C, B57, RA5-C, and OV-1 Mohawk aircraft in waves of improving technology throughout the 1960s. Improvements included replacement of single-element detectors with small arrays of detectors, replacement of InSb with Ge:Hg detectors (halving the NET difference), and replacement of the arc lamp with gallium arsenide (GaAs) diodes. In a final line-scanner version, film was developed on-board in near real-time, allowing the crew to locate targets and vector in strike aircraft within minutes. Real-time viewers were developed to see a near real-time moving map display in the aircraft. This method was better than developing film, but the detected targets were always behind the aircraft by the time the operator could see them. So this modification was also unsatisfactory when tracking moving targets.

An IR system capable of fast-frame imaging was needed for a combatant to find his target, track it in real-time, and deliver a munition without ever breaking contact. He could control the entire kill chain and minimize latency.

Such a system, which became known as FLIR, was developed by the Air Force and TI in 1964. It was then mounted in a C-47 transport aircraft that had been converted into a gunship and deployed to Vietnam in 1965. The FLIR and its immediate successors made a dramatic impact on the battlefield. For the first time, traffic along the Ho Chi Minh Trail was interdicted effectively, and even small units of Viet Cong moving through foliated countryside were frequently detected.

The first FLIRs used 40-mil (i.e., approx. 1,000 μm) Ge:Hg LWIR detectors in 1x3 and, later, in 2x15 parallel/serial array configurations with mirrors to scan them across and down the FOV every 20 milliseconds (50-Hz frame rate). Output from the detectors was used to modulate the intensity of a Matricon CRT that was directly viewed by an operator. But the FLIRs were expensive, large, heavy (approximately 600 lb), energy inefficient (approximately 1,000 W), and the image quality was less than ideal. In addition, their wide FOV with relatively low resolution was not practical for longer range fire control systems.

These problems were addressed with technological improvements between 1968 and the end of U.S. involvement in the war in 1972. One improvement introduced larger, one-dimensional parallel scanners using linear arrays of up to 400 channels with much smaller Ge:Hg detector sizes that were on the order of 3 mils square. These image-plane scanned arrays sensed the IR imagery through relatively long focal length refractive lenses. Twelve-inch focal lengths with 3-mil elements produced resolutions of 1/4 milliradian. Optical switching mechanisms provided for on-command selection of wide and narrow FOV. Signal processing was achieved by

EO multiplexer imaging light-emitting diodes (LEDs) formatted in the same geometry as the detectors and scanned off a mirror assembly connected directly to the IR scanner. This concept was a forerunner of the next-generation Common Module FLIR approach.

Another major improvement occurred in 1970 when Ge:Hg detectors were replaced by the first production LWIR MCT photoconductive detectors. MCT is a nearly ideal, intrinsic, photodetector material, with a direct, compositionally tailorable, bandgap as opposed to Ge:Hg, which has an extrinsic, fixed, indirect bandgap. Consequently, MCT detectors have a much higher photon absorption coefficient (providing better sensitivity with thinner detectors), much lower dark current (enabling higher operating temperatures), and a bandgap tuned exactly to the LWIR atmospheric window (enabling maximum signal-to-noise ratio). Much smaller 2-mil MCT detectors were made in 1x180 parallel configurations, cooled to 77 K (instead of 28 K for Ge:Hg), and interlace scanned (for 360 lines of resolution). These higher-temperature systems with smaller detectors that allowed smaller optics as well were much less expensive to build, were one-third the volume of Ge:Hg detectors, weighed only 200 lb, consumed much less power, and exhibited exceptionally crisp imagery.

Alternative solutions to FLIRs for night vision were also intensely investigated during the war. LLTVs were prime candidates. In their most basic form, LLTVs combined a multistage image intensifier with a vidicon. Ambient light was insufficient for the poor quantum efficiency photocathodes, and spectral response did not extend far enough into the near IR to detect significant sky glow as did later image intensifiers. Covert active illumination was added by placing filters on artificial sources such as xenon lamps. After lasers were invented in the early 1960s and practical neodymium-doped yttrium aluminum garnet (Nd:YAG) lasing media provided invisible 1.06- μm laser light in the mid to late 1960s, active

pulse-gated LLTVs⁴ appeared to be a viable competitor to FLIRs. Since a major concern was seeing through battle-field smoke and dust, the systems were pulse-gated so that discrete pulse returns were timed to correspond to ranges near the target. Image intensifiers on the LLTVs had rapid response and could be shuttered to open at the intended pulse return time and then closed to lock out reflections from shorter range aerosols. This technique gated out intermediate range returns from dust and smoke. According to Ponomarenko and Filachev [29], the Russians experimented with similar night vision approaches and built a prototype device using a ruby laser in 1963.

Pulse-gated LLTVs had several drawbacks compared to FLIRs including the poor penetration power of their shorter wavelengths, and the fact that they were active raised concerns that they were not sufficiently covert. In that era, they were soon replaced by FLIRs, but they later re-emerged in more modern fire-control systems as complements to FLIRs. They can complement FLIRs due to their ability to provide extra-long target identification range by exploiting their much shorter wavelengths to obtain smaller optical diffraction blur spot sizes and thus higher resolution.

5.3 TI FLIR DEVELOPMENT [21]

This subsection is a history of FLIR development at TI as extracted, edited, and condensed from the recollections of Kirby Taylor. Also included is historical information from TI's website [43] where the latter is then further expanded with inputs from Taylor for this history. However, information from other sources is also included, and those sources are specifically cited. Taylor, an electrical engineer, was uniquely positioned to provide historical recollections. He witnessed first-hand the engineering and the political struggles both as a contributor to the FLIR design process and as a contractor field support engineer in the Vietnam theater. Taylor's informative stories of those struggles provide insight into the

challenges of war-time technology insertion. Some of them are included in Appendix B.

5.3.1 First FLIR System: FLIR 1

In 1963, TI engineers began to develop a real-time, two dimensional IR viewer with \$30,000 in company funding. The approach was to investigate the feasibility of adding a second scan mirror to the single-axis line scanner, which would supplant the forward motion of the aircraft as a means to generate the second scan direction. This real-time IR imaging device was called FLIR-Forward-Looking Infrared. The name came from the fact that the previous devices were mappers that looked down, but the new, two dimensional scanner was now able to look forward. The study included some basic scanning experiments that determined the concept's feasibility. TI hurriedly prepared an unsolicited proposal to ARPA, later renamed DARPA. DARPA's charter was to investigate high-risk, but high-payoff, visionary new technologies and was, in a sense, the "venture capital" arm of the DoD.

DARPA said the concept was interesting but there was no military requirement for a FLIR because combat was not conducted at night. While obviously disappointed by this response, TI persisted and approached the AFAL at Wright-Patterson AFB, which had been previously involved with TI in line-scanner source selection and in detector development. The Air Force saw value in night imaging but required TI to bid on the project in an open competition. TI's idea was no longer considered proprietary, and eight companies competed for one of the two \$250,000 contracts. However, all competitors eventually dropped out and the award went to TI.

TI began work in October 1964 with a dedicated team of physicists and engineers. In May 1965, the first exploratory flight test was conducted. A major factor in this accomplishment was having access to a detector factory, cryogenics from ongoing mapper programs, the baseline Kennedy scan-

⁴ Coauthor David Schmieder was on the team under Army contract to integrate pulse-gated LLTVs into tank fire-control systems while employed by Delco Division of General Motors in 1970.

ner design, and engineers having system experience with IR optics, detectors, and electronics.

The basic sensor consisted of a two dimensional, all-reflective optics scanner; a three-element Ge:Hg detector array cooled to about 28 K by a Norelco Stirling Cycle cooler; electronics; and a display. The display was customized from a color TV tube modified to three black and white guns to match the three element detector geometry. The technique used on this sensor was serial scan but with the given detector geometry, it should more properly have been called serial/parallel. The optical configuration was a complex, two-axis, split-aperture scanner adapted from the Kennedy single-axis mapping scanner. Several illustrations of the optics are shown in Appendix C.

By the end of 1965, TI delivered a crude but flyable bread-board model, as shown in Figure 5-1. It was a simple prototype with marginal imagery as shown in Figure 5-2 and was not yet ready for testing in a critical airborne application. The frame rate was adequate for most applications at about 24 frames per second with a 20°x40° FOV. Such a large FOV was not compatible with longer range fire control systems.



Figure 5-2. Image from first flyable TI FLIR (Photo credit: Kirby Taylor [21]).

In addition, the prototype had a poor NET of about 0.7 °C, which is useable for clear weather, but not for high-humidity conditions or long ranges.

Nevertheless, the Air Force in Washington, DC was very interested in the FLIR technology and wanted to test it in a battle zone. They ignored TI's objections and installed it on a C-47 aircraft⁵ and scheduled an operational flight-test program over the battle zones of Southeast Asia.

Bien Hoa Air Base in Vietnam during the rainy season was headquarters for the test. For TI, it was a bad engineering situation, but Kirby Taylor flew the test missions to ensure the system worked as well as possible. Early flights immediately showed that the NET was not adequate for the mission. Generally, the system could detect rivers, roads, some vehicles, buildings, and similar larger targets. The FLIR was installed pointing forward, and the guns were pointed to the left side of the aircraft, which was not an optimum configuration. After about 6 weeks, the aircraft returned to Clark Air Base and the equipment was removed for return to the U.S.

As would be expected, the official report was critical of the FLIR's performance. Pat Haggerty, president and board chairman of TI, was seated on the prestigious Defense Science Board and heard the disheartening news as it was briefed. Haggerty was appalled since the results obviously reflected



Figure 5-1. First flyable FLIR made by TI. It was the first FLIR to be tested on an AC-47 gunship (1965). Right inset shows Kirby Taylor standing beside the gunship at Bien Hoa Air Base, Vietnam (Photo Credit: Kirby Taylor [21]).

⁵ The C-47 was the military version of a DC-3 used as transports and later used as AC-47 "Spooky" gunships also nick-named "Puff the Magic Dragon," after the popular song by Peter, Paul, and Mary because gunship cannon muzzles produced so much smoke and fire like dragons.

poorly on TI and it eroded his support for further internal FLIR development. However, other managers, such as Ray McCord, still strongly believed in FLIR technology. McCord continued to press for resources to finance, for instance, critical IR detectors even as skeptical management cut overall research funding. He was determined to keep it a priority even as many in TI were willing to either eliminate or downgrade the importance of the IR program.

Despite the FLIR's poor performance in Vietnam, DoD leadership realized the importance of FLIR technology, particularly as part of the circling gunship concept. They felt that during night missions, having an onboard FLIR to locate and recognize targets was critical because it would allow the aircraft to accomplish the mission it was intended for: to attack targets, especially ground truck convoys, by circling at a constant altitude and firing large-caliber guns. Whereas the gunship's effectiveness was initially thwarted because the enemy hid during the day and moved at night, FLIR technology, much more than flares or low-light-level TV, enabled these aircraft to complete missions at night. Therefore, in spite of the Air Force's disappointment with the FLIR lab model, they awarded TI a million dollar contract for continued FLIR development. TI then successfully produced a series of gunship FLIR systems capable of detecting targets at increasing ranges.

Key DoD supporters backed TI's efforts, but they also pressed for results. In one case, Air Force Major Jim Krause appealed directly to McCord to urge for improved performance. McCord, with company support, responded with a commitment to solve remaining problems without additional cost to the customer. As a result, TI successfully produced a series of gunship FLIR systems capable of detecting targets at ever longer ranges. Krause, now a lieutenant colonel, went on to fly hundreds of missions including those on the newly introduced and more capable Spectre AC-130 gunships. He taught new operators and observed performance characteristics to provide direct feedback to development engineers. Taylor personally saw him return from a mission on one plane, jump off, and run to board another outbound plane to

fly the next mission. Promoted to colonel, Jim Krause went on to become Director of the Air Force Avionics Lab.

5.3.2 FLIR Design Progression

FLIR II. The experience gained in these earlier programs was devoted to developing an improved version of FLIR using a 15x2 Ge:Hg detector array. In the FLIR II, the NET (per channel) was reduced to approximately 0.4 °C, and the sensor was configured as a bombsight complete with an analog computer to display the Continuous Computed Impact Point. The system was installed onto a modified A-26 aircraft, the Lonesome Tiger. Early on it was determined that the sensitivity was still lacking, and this shortcoming forced another modification.

FLIR IIA. A technically significant improvement to the FLIR II was a modification often referred to as a "large top hat" scanner. The optical scheme provided for a reimaging imager to enable cold shield efficiency improvements, more than doubling the detector detectivity (D^*) above 2×10^{10} . The NET improved to approximately 0.15 °C.

Trails and Roads Interdiction Mission (TRIM). The Navy was interested in determining a method to eliminate Viet Cong logistics along the lines of communication. They devised a weapons system for a Navy P-2V that included sensors and guns. The TRIM program built four planes to be deployed to Vietnam. Two had TI FLIRs and two had HAC FLIRs. Extensive, in-country testing was conducted, and those results eventually led to the A-6 TRIM and later A-6 Target Recognition and Attack Multisensor (TRAM) programs.

AC-130 Spectre Initial Development. An updated and modified version of the FLIR II was incorporated into the early AC-130 gunships. Field tests in Southeast Asia demonstrated the need for IR capability, but the weapons being used needed a targeting system with much longer range, narrower FOV, and more sensitivity.

FL-13. To address the performance requirements learned from field operations, TI initiated an internal R&D (IRAD or IR&D) program to configure a new FLIR concept. The generally accepted theory was that a "push broom" scanning system using a linear detector array of up to 400 channels was a solution to the issue of sensitivity. The FL-13 design set out to demonstrate the concept first with a 100x1 focal plane array (FPA) of Ge:Hg detectors cooled by an AD Little (Gifford-McMahon cycle) cooler. The larger arrays with more mass and more heat load needed the greater cooling power that this new cooler would provide.

The FL-13 explored the design concept called an "EO multiplexer" (electro-optical multiplexer). A multiplexer is typically an electronic circuit that takes multiple input channels and converts them into one serial output channel. So for FLIRs with multiple detectors, all producing simultaneous outputs but from different parts of the image, a multiplexer funnels these separate channels into a single serial stream of video that can be displayed on a CRT monitor while keeping the signal from each detector spatially registered with the scene. The electronics for doing this were quite formidable in this era for many reasons. They included the fact that the bandwidth of the combined channels, in a serial output, had to be higher by a multiple equal to the number of detectors. Moreover, the frame rate had to be high to avoid display lag and image flicker. The sampling and switching circuitry needed to merge the many channels was also a challenge. An effective way to solve this challenge was to simply convert the detector signal to visible light using LEDs. Then, let a TV camera look at the parallel image that was output by a scanning line array of detectors across the optical image. Since the TV outputs a serial video representation of the detectors' parallel output, the output can then be viewed on a standard TV monitor. This TV camera was effectively an EO multiplexer.

In the FL-13, a detector array is shown an image reflected off a scanning mirror, and a geometrically similar LED array is imaged off the back side of the same mirror or off a mechanically connected mirror, to create a visible image of the IR scene. That image, in turn, is optically relayed to the TV camera.

Original EO multiplexers incorporated a nonvisible Ga:As LED array that required viewing with a silicon vidicon or other vidicon that was sensitive to the 0.9- μm spectral emission of that LED array. Later applications were able to take advantage of newer visible (0.66- μm) LEDs that could be viewed either directly by an observer or viewed by the EO multiplexer to provide remote displays in standard TV formats.

The development of large detector arrays and EO multiplexers together greatly improved FLIR performance but also simplified their design and improved their producibility. Early FLIRs had only a few detectors and were scanned at slow rates due to detector bandwidth limitations. Video output rates were too slow for standard displays with high frame rates. Accordingly, workarounds were used such as special CRTs with multiple scan beams so each detector could drive a separate beam. Also, display phosphors with slow time constants were used to diminish flicker. Of course, these FLIRs performed poorly both because of detector and display limitations. However, standard video output could be obtained by using a "scan converter," which consists of a nonstandard display, as described above, but then looking at it with a standard TV camera. This approach is less than ideal because more resolution is lost by introducing yet another transfer function, the TV camera, in the chain.

The FL-13 became the first TI FLIR with all-refractive optics, multiple FOVs, and an EO multiplexed standard TV output signal. Special displays and recording equipment were no longer required. The breadboard system provided two FOVs: 15x20 and 5x7 degrees.

A-6 TRAM, B-57 Tropic Moon III, AC-130 Spectre Upgrade.

Three new weapon platforms were launched using FLIRs based on the FL-13 concept: the A-6, B-57, and the AC-130 aircraft. Detector arrays of 400x1 and 200x1 Ge:Hg detectors and AD Little coolers were the baseline. The FLIR systems were the A-6 TRAM, the B-57 Tropic Moon III, and the AC-130 Spectre Gunship. Of these, the Spectre was the most successful and later became a prime weapon using even more modern components.

To gain the optimum transfer function in the AC-130 Spectre, an 875-line, rather than the more standard 525-line, closed-circuit TV system was used for EO multiplexer oversampling. The higher 875-line spatial sampling of the 400-line detector array improved resolution. Eventually, the narrow FOV was reduced to approximately 2° and below 1/6 milliradian IFOV to further improve overall resolution. AC-130 FLIR (AN/AAD-4, AN/AAD-5, AN/AAD-6, and AN/AAD-7) continuous improvements led to the incorporation of MCT detector arrays of 180x1 in AC-130s by 1970/1971.

OR-89 AA FLIR. The OR-89 AA FLIR was the first FLIR designed specifically for an aircraft, the S-3A Viking, and the S-3A was the first aircraft designed with a FLIR sensor planned into the original baseline design. In what was effectively yet another extension of the FL-13 concept, a challenge was taken in this program to reduce the weight of the system by a factor of two compared to the earlier AC-130 Gunship systems. The total package, with all electronics boxes and gimbals together, had to weigh 234 lb. The steps taken to reduce system weight were significant then because new technology was required throughout the system: MCT detectors, visible LEDs, and a TI-built cooler.

The strategy was to reduce the element size of the detector array from approximately 75 μm square to 50 μm square. This reduction allowed for reducing the optics focal length and diameter to 2/3 of their original values while maintaining performance. Reduction of the optics dimensions translated to a volume reduction of approximately $(2/3)^3$, or by about 1/3. If the designers used the existing design rules where the weight per volume was constant, then the weight would have been reduced accordingly. Other components did not scale in that exact manner, but they were close enough that the goal of half weight was achieved.

The new MCT detector arrays required cooling to only 77 K, compared to the 28 K required by Ge:Hg detectors. This new higher temperature allowed TI to design a new cooler to replace the AD Little cryogenics to reduce the size, weight,

and power. The design also incorporated visible LEDs in the EO multiplexer to improve reliability and enable the use of smaller, simpler, lower-cost TV components.

The program was successful and more than 200 of the systems were built for the S-3A Viking. Other users adapted this design into various aircraft platforms: Canadian P-3, USAF Pave Low helicopter, and Combat Talon, along with some other special mission programs.

5.4 HAC FLIR DEVELOPMENT

This section is a synopsis of FLIR development at HAC as extracted, edited, and condensed from the recollections of Robert Sendall [19]. Sendall, much like his contemporary Kirby Taylor at TI, was an important participant in FLIR development. Sendall managed FLIR programs but also had a major impact on modeling FLIR performance. His insights resulted in design optimization algorithms that showed the way to improved system performance including all-important observer effects. Those insights provided the modeling foundation fundamental to the design of FLIRs well into the 21st century.

In 1964, a HAC IRAD program called an "imaging scanning experiment" was started to learn about real-time IR imagery. The effort was to put a 56-element PbSe linear array in a PhoenixIRST and use a gimbal scan to scan out four 56-element bars of imagery providing 224 lines of IR imaging data that could be displayed on a memo scope. The system was sensitive in the 3–5- μm region and generated imagery for evaluation. The design was based on NET optimization for sensitivity and on minimized individual element IFOV for maximum resolution. It was expected to provide a high-resolution, low-frame-rate, real-time IR image. But these parameters were incomplete, because, in part, they did not account for the role of human visual processing in the perception of displayed video information. But, very importantly, this effort provided the beginning of an understanding of what all the optimization parameters for a real-time IR imaging system should be.

While this system provided cosmetically pleasing images in an observation deck "roof house" environment, it was oversold into the Red Sea flight test program at Eglin AFB in competition with TI. TI had built the first successful long-wavelength FLIR by modifying a line scanner with a scanning mirror to provide a framing system to generate a TV-like image. Clearly, the long-wavelength TI system was more useful for military applications in Southeast Asia. While the TI system originally only had a single element of Ge:Hg and a single-gun CRT, it soon went to three elements using the three-gun structure used in color displays to enable each detector to drive a separate gun. Even with those improvements, it was clear that more detectors were needed to get significant performance and, at least for experimentation, TI developed a larger array and made it compatible with a British Matricon multigun tube displaying the image.

After the Red Sea exercise, HAC applied what was learned to the development of a high-performance, 8–11.5 μm , real-time imaging system and also started on lower-performance night sights using 3–5 μm technology.

Engineers assigned to this activity at HAC were well versed in theory and mathematics. Accordingly, they recognized the importance of cold shielding⁶ the detectors and the complication of the human observer as the interface. They became familiar with the image evaluation efforts of Otto Schade, Jr. [38], Fred Rosell [39], Coltman and Anderson [44], and others. HAC engineering efforts led to very high-performance systems, but they were very difficult to build.

During one competitive procurement, such an optimized HAC FLIR was engaged in a flight test versus a less optimized Aerojet design, and it led to a major advance in future FLIR specifications. The fact that the two systems had similar NET and IFOV requirements, but obviously had very different effective performance, led Lucien Biberman of IDA to form a

committee to investigate the differences and define a new set of performance parameters for future FLIR specifications. At the time, NET was commonly used as the measure of sensitivity, and IFOV was used to define resolution. It was clear that these practices were not adequate and did not successfully optimize the HAC system.

The original committee met at IDA and was chaired by Biberman, and included such well-known EO sensor experts as John Johnson from NVL, Richard Lagault from the University of Michigan TI, Robert Sendall from HAC, and John Jameson from Aerojet. Robert Sendall presented the concepts of Minimum Resolvable Temperature (MRT), a major new concept he originated, as well as existing metrics such as Amplitude Transfer Function (ATF), and Modulation Transfer Function (MTF) as three important parameters for FLIR optimization and specification. These functions included the complete system and the man-machine interface. The committee changed with time but resulted in a recommended FLIR specification document based on those originally presented parameters. Those parameters were subsequently optimized in the HAC Advanced FLIR (AdFLIR), which is discussed in Section 5.4.1.

5.4.1 The Advanced FLIR (AdFLIR) for the Air Force

In 1965, the first high-performance, two-FOV FLIR was started on IR&D funding and then was completed for the Air Force AdFLIR 698DF contract. In this contract, HAC was competing with Aerojet, which tried to build a similar system. The HAC system used a staggered linear array of 176 Ge:Hg detectors cooled to about 28 K. The elements in the array were staggered to provide space for individual cold shielding of each detector element in addition to a slot shield for the whole array. The elements were also spaced apart so they could be interlaced to provide 352 scan lines per frame. This array was scanned in the horizontal and dithered in the vertical for

⁶ The term "cold shielding" refers to placing structured barriers around the detectors so that internal heat radiation cannot fall on the detectors and therefore reduce their sensitivity. Since all radiation exhibits quantum fluctuations, all radiation falling on the detectors increases the apparent noise output from the detectors.

interlace at the end of each field to provide an image data rate of 60 fields per second for a frame rate of 30 frames per second.

Two different telescopes and scanning systems were used to provide two different FOVs depending on the position of a field-switching mirror. The scan was provided for each telescope by object space scanning with a pair of counter-rotating wedge, or risley, germanium (Ge) prisms. If these prisms were spun at constant speed, a sinusoidal scan with minor distortion (called "dog bone") resulted. To improve this scan, elliptical gears were used to reduce the dog bone as much as possible. Two other design challenges of this scanning approach were "Narcissus" and "ghosts." Narcissus was the result of the prisms presenting a parallel plate of Ge to the telescopes when the system was in the center of the scan; the antireflection coatings on the prisms had to be of high quality to minimize the detectors' reflection of themselves as a cold object in the center of the FOV. Ghosts would also result from imperfect antireflection lens coatings which allowed emissions from internal structures and other parts to reflect onto the detectors.

The array of detectors was easier to make because of the spacing and staggering of the elements with individual shields. This design provided effective cold shielding of these background limited elements, which led to almost theoretical sensitivity. The array and matching preamp multiplexing modules were designed around the Dewar and were mated with a cryogenic refrigerator in the sensor assembly. While each detector had limited bandwidth, the output of the whole detector assembly was a very wide bandwidth, single-video signal generated by sampling and electronically multiplexing the electrical signal of each element. Finally, the output image from two interlaced 176 scan lines only produced 352 display lines compared to standard displays of the time which presented 485 active lines. So, unless this lim-

itation was addressed, the display would appear with visible gaps between scan lines. Accordingly, the CRT beam used for display had to be vertically dithered at high speed to eliminate the line-to-line gaps and thereby minimize raster line structure.

The electronics and special display of this theoretically ideal design were very difficult to build. When built in the original model, this design produced a very clear image, but integrating it with aircraft was also difficult.

5.4.2 EO Vision System (EVS) FLIR for the Air Force B-52 Aircraft

Although the EVS B-52 FLIR was the result of an Army request to equip the proposed Cheyenne attack helicopter, it surprisingly ended up being the first production FLIR and was installed on the B-52 aircraft for the Air Force in 1969. The EVS system included both TV and FLIR systems for enhanced, low-level penetration with improved obstacle avoidance. It also provided the pilot with a view out of the cockpit if it had to be closed for flash protection because of a nuclear event. This capability made the flight safer and more effective and provided for some target-area damage assessment. The EVS FLIR was basically the FLIR designed for the Army's Cheyenne "PINE" FLIR, which had a scan converter to provide a standard TV output. This scan converter resulted in a loss of performance but made the helicopter integration easier and the imagery was adequate. The FLIR design effort led to a producible, improved FLIR based on the fundamentals of the AdFLIR. It became the ultimate FLIR using Ge:Hg.

This FLIR had a linear array of 176 Ge:Hg elements⁷ with one-element spacing between the elements so that horizontally scanned fields could be interlaced to form a complete frame of 352 lines. Cold shielding was still paramount to the design and was accomplished using reimaging optics so that an optical exit pupil⁸ could be located inside the Dewar and

⁷ Sendall reported that he may be wrong about the final number of elements in the array after iterations.

⁸ Optical exit pupils allow the placement of mechanical "stops" around the pupil to intercept internal heat emissions and prevent them from falling on the detectors. If the stops are cold, they absorb but cannot effectively re-emit.

stopped with a cold stop. The optics could therefore be rather slow (i.e., high f-number) and include a scanning mirror in the converging beam to eliminate the prisms. (Scanning generally should be done with parallel rather than converging light since the latter results in a curved image plane, but high f-numbers mitigate the curvature.) The array was still electronically multiplexed as it was scanned horizontally, but now interlace was simple and, because the exit pupil was inside the Dewar with a cold stop, there was no need to stagger the detectors to allow space for individual cold shields. These characteristics simplified the system, but the EVS FLIR still required a special (nonstandard TV) display that could move the CRT beam quickly in the vertical since the display scan was fast in that direction (to keep up with vertical multiplexing) and slower in the horizontal scan direction. It also required a good broadband video amplifier to prevent loss of vertical MTF. The resulting display looked like a normal 2-1 TV raster scan but it was not. There were over 300 systems originally built and, with spares, over 400.

5.4.3 The Discoid Serial Scan FLIR

Toward the end of the 1960s, HAC was looking ahead for new design concepts besides those based on Ge:Hg. The B-52 FLIR and others revealed the disadvantages of having a nonstandard TV display format. In the mid-1960s, HAC was impressed with the Swedish AGA Vision 3–5 μm imaging system. The design was very well analyzed and built. It provided clear and uniform images, especially for a mid wavelength system. However, it was not possible to build such a system sensitive in the 8–11.5 μm region because the Ge:Hg detectors did not have the necessary frequency response, and the desired performance required a significant number of detectors. A solution was found with the development of new detectors.

The development of MCT detectors (discussed in Section 4.5) continued throughout the 1960s. They provided a vast improvement over Ge:Hg detectors because they required

cooling to only 77 K instead of 28 K, offered almost any spectral band out to and beyond 14 μm , and had fast temporal response. DARPA funding continued throughout this period although they were skeptical of eventual success. A DARPA executive said, "HgCdTe was the detector of the future and it always would be." However, in the late 1960s, arrays were being successfully produced.

HAC engineers now saw the possibility of building TV-compatible systems by scanning a linear array of elements over the FOV with the elements in series rather than in parallel. The line of elements was horizontal and was scanned in the direction of a horizontal line. Since each detector was looking at a different part of the scene, but all detectors were scanning in the same direction, their outputs could be merged by using time delay and integration (TDI). This merging resulted in improved sensitivity since the signals would add linearly while the independent noise would only add as the square root. Moreover, image uniformity was greatly improved, and there was no longer any need to balance detector channel outputs since all the channels were summed together anyway. This FLIR design approach was called a "discoid" design after the type of two-mirror object-space optical scanner used to produce a raster scan at TV rates.

Because of the strongly desired standard TV output format for many applications, HAC applied the discoid concept to all FLIR applications. Unfortunately, the approach had many limitations and inefficiencies. An important limitation was the inability to add more than a few dozen detectors to the focal plane array due to scanning geometry limitations. Moreover, for many Army applications, a TV format provided no advantage. Indeed, the direct-viewing of scanned LEDs, as had been used in the many experimental night sight systems HAC built for NVL, was better suited to these applications. Also, the possibility of using an EO multiplexor, even with the inherent loss of performance, supported the parallel-scanned common modules. Nevertheless, the serial

scan system was easier to build for moderate performance applications and was easy to make more compact. More of the systems would have been built except for the decision to adopt the parallel-scan common modules as the FLIR for all government applications. While the HAC discoid FLIR design did not become the basis for the FLIR common modules, the concept of using TDI was ultimately adopted for second generation (GEN2) scanning FLIRs.

5.5 SUMMARY OF VIETNAM-ERA FLIR DEVELOPMENTS

The combined demands of the Cold War and the Vietnam War motivated the invention of FLIRs. They were needed in the Cold War for strategic bombers to provide night vision for both low-altitude, under-the-radar navigation and for navigation with shuttered windshields used to prevent flash blindness from nuclear explosions. They were needed in the Vietnam War for night targeting of enemy ground forces. Key prior developments in detectors, scanning systems, cryogenics, electronics, and the understanding of observer impact on system performance provided the technology for FLIRs to emerge. However, it was the close working relationships, sometimes contentious, among industry engineers, their management, government organizations, and the military users that brought it all together. These FLIRs were fledgling devices that were custom-made and expensive. Chapter 6 discusses the ongoing relationships that initially enabled successful FLIR development and how they were instrumental in creating the so-called "first generation" (GEN1) FLIR, which it actually was not, but it was the first series of FLIRs mass produced from standard components.

CHAPTER 6. GEN1 COMMON MODULE FLIR

6.1 INTRODUCTION

In the late 1960s and early 1970s, linear arrays of intrinsic MCT photoconductive detectors were developed and eventually became producible. These detectors allowed LWIR FLIR systems to operate at 80 K with a single-stage cryoengine, making them much more compact, lighter, and significantly lower in power consumption. As a result, in the 1970s, IR applications greatly increased and a strategy for high-volume production was needed for this "first generation" of IR sensor systems. Many innovative approaches had been applied to FLIR designs including parallel, serial, and parallel-serial. But parallel was the most compatible with existing detector technology and support electronics. Many essentially similar parallel FLIR designs were built and fielded. However, standardization was needed for affordability. Accordingly, a set of modules evolved that did not come from new technology per se but, instead, largely codified the existing first generation of technology in the form of common building blocks that became known as "generation 1" or simply "GEN1" FLIRs.

This chapter describes GEN1 FLIR emergence from supposedly existing technology developments. However, as this history shows, while that technology may have been largely existing, the need for commonality for cost reduction still required much innovation, especially on the part of second-source suppliers who did not have access to the proprietary technology of earlier developers. These suppliers often had to reinvent either the same, or come up with different approaches, while still being compatible with rigid interface control specifications.

During the 1970s, the principal FLIR industry players were Honeywell, HAC, SBRC, and TI. Others that became involved later included Aerojet, AVCO, Fermionics, Ford Aerospace, General Dynamics, GE, ITT, Martin Marietta, McDonnell Douglas, New England Research, HRB Singer, and Rockwell. Few flourished in this business and either merged, spun off,

or exited when they failed to capture sufficient government support.

Other major players came from DoD agencies, Federally Funded Research and Development Centers (FFRDCs), and universities. DoD agencies included ARPA (later renamed DARPA), NRL, AFAL, and NVL (later renamed NVESD). FFRDCs and academic organizations included IDA and the Henry Levinstein group at Syracuse University funded by the Air Force. Still other nonindustry groups made significant contributions as well.

Much of this chapter comes from manuscripts provided by Kirby Taylor, whose important role in FLIR development was described in earlier chapters, and by Charles Hanson [45]. Hanson was employed by the U.S. Army NVL during this era and was the Contracting Officer's Technical Representative (COTR) for several night vision programs. In this role, he could directly observe, and in some cases influence, some of the important events leading to the development and procurement of FLIR common modules. Finally, co-author David Schmieder contributes his insights from his experience at Martin Marietta, now Lockheed Martin, as a member of the team that developed a common module second-source supply capability and as lead author of the *FLIR Common Module Design Manual* [46].

6.2 VIETNAM-ERA CONTRIBUTIONS [45]

By the mid-to-late 1960s, the Vietnam War began to show the worth of MWIR and LWIR sensors for airborne night interdiction. As a result, the Army began to step up sensor development in these devices for ground and lower-altitude airborne applications. They developed plans to accelerate development of multiple night vision devices for Vietnam deployment within 2 years. The program, Southeast Asia Night Operations (SEA NITEOPS), began in mid-1967 with a budget of about \$6 million. By 1968 its budget had increased to \$20 million. It not only made significant military contributions with little actual hardware, but it provided valuable information to guide future developments. In particular, the program established the role of the FLIR.

Experimental FLIR systems were built to address the requirements of Army man portable and armored vehicle systems. Most included parallel scanning schemes of up to 120 linear detector arrays. EO multiplexers (i.e., TV cameras) were used and electronic multiplexers were also designed. But the electronic multiplexing components of that period (1969–1975) were marginal for the data rates, and scan converters required to produce TV-compatible signals were relatively large. An exception to this situation was a missile seeker program that employed 60 channels and scanned vertically. This development eliminated the need for a scan converter since the 60-channel data rates were within the multiplexer capabilities of the day. These early systems were eventually replaced by FLIRs based on common modules.

6.3 EARLY NVL DEVELOPMENT ACTIVITIES [45]

Army FLIR involvement began with the development of thermal-imaging sensors of modest performance for ground-based applications. By 1971 the need for FLIRs was clearly established because of their advantages over image intensifiers and active LLTVs. While the Air Force interest was driven by the need for remotely viewed, high-performance, airborne FLIRs, Army interest was for larger quantities of directly viewed, shorter-range, hand-held and vehicle-mounted FLIRs. For example, in the early 1970s, the Phillips Broadcast Equipment Company (later Magnavox) developed the Hand-held Thermal Viewer (HHTV), funded by NVL. The system used a 48-element, parallel-scanned, photoconductive PbSe MWIR detector array with 5-mil pixels, produced by Opto-Electronics of Petaluma, CA, later acquired by Textron. The detector was cooled with a four-stage thermoelectric (TE) cooler developed by Marlow Industries in Garland, TX. It was scanned at low frequency, about 15 frames per sec, without interlace. The scanner was bidirectional, and there was considerable flicker at the extremities owing to the low scan frequency. The IR optics were $f-1.0$ with a 2.5-in. aperture, giving an IFOV of 2.0 milliradians. The system, officially designated "Viewer, Infrared AN/PAS-7" (Figure 6-1), weighed 6.5 lb without the battery and almost 12 lb with the belt-mounted battery and connecting cable. The display was a small CRT, and a photograph of the display imagery is shown in Figure 6-2.



Figure 6-1. The HHTV, AN/PAS-7 (Source: U.S. Army).



Figure 6-2. The AN/PAS-7 display (Source: U.S. Army).

The technology developed under the HHTV program provided the foundation for the Dragon Thermal Sight, which was a fire-control system for the Dragon missile. It used a 64-element, parallel-scanned PbSe array, also cooled with a four-stage TE cooler. The Advanced Production Engineering (APE) program was funded by the U.S. Army Missile Command at Redstone Arsenal, AL, and managed by NVL. The APE program was completed, but the follow-on, low-rate initial production was never begun because of the promising technology of the Common Module program.

6.4 EMERGENCE OF COMMON MODULES

The emergence of common modules is largely the result of the efforts of both TI and the U.S. Army NVL. Specifically, TI's design approach and advocacy were key to common module development. In addition, various DoD organizations, including the service branches, strongly pressured industry to create lower-cost approaches. Moreover, strong government leadership was essential in creating an acceptable tri-service solution so that maximum economies of scale could be achieved. As expected, the perspectives of TI and NVL witnesses about the development of common modules differ. Neither is an unbiased observer. Their differences are probably accentuated by fading memories of events, and especially dates, from that era. Nevertheless, to provide the best historical treatment, the history of that critical time is presented from the vantage point of a key witness inside each organization, i.e., Kirby Taylor from TI and Charles Hanson from NVL.

6.4.1 TI Common Module Development Perspective

After the Vietnam War, DoD planners acknowledged the power of the FLIR system, but were wary of its relatively high cost. In March 1972, TI received a letter from the ARPA director explaining that the DoD could no longer afford the FLIR system and asked why each unit cost several hundred thousand dollars. TI explained the enormous development costs required to make FLIR an integral and effective part of each gunship mission, but the DoD still considered the cost of FLIRs too high.

TI recognized that FLIR had become a major financial success for the company, and it did not want to lose a system it invented to a growing number of competitors. After a thorough analysis, TI concluded that each FLIR application had its own unique set of requirements. Since 1964, TI produced 385 FLIR systems with 55 different applications, and the production rates of each configuration were too low to achieve any economies of scale. Therefore, TI began to develop a Common Module FLIR concept. The concept was based on the premise that certain functions of an IR sensor were not mission specific and could be made universal without

affecting the sensor's mission performance. Such a commonality would not only make custom design and development unnecessary, it would also decrease the time committed from inception to availability, make volume production possible, and greatly reduce the cost. However, to be effective, such a concept had to be endorsed by all three military services.

Even though the Common Module FLIR required significant changes to TI's designs and caused much worry that a common module approach would commoditize the business, the company adopted the concept as the central theme of its IR strategy. In November 1972, TI began to build prototype common modules.

In early 1973, all three military service chiefs declared support of the common module concept, and TI began to win development programs using common module designs. The concept became an official standard in 1976. Competitive technologies didn't recede easily, and TI was also involved in competitive developments for a number of programs, most notably the tube-launched, optically tracked, wire-guided (TOW) missile launcher sight (Figure 6-3). Pressure also grew to develop second sources for the modules even though TI developed much of the common module technology on its own. A second-source award was made in 1980.

TI's determination to stick to a strategy based more on economics than technical wizardry paid great dividends. The company regained businesses they originally lost. They won production of the TOW sight, the M-60A3 Tank Thermal Sight, the Bradley Fighting Vehicle sight, the M1A2 tank gunner and driver sights, and many others. The F-117 stealth fighter fire-control system was built around a TI Common Module FLIR. All of these systems were used in Operation Desert Storm and the subsequent Gulf War. The Federal Republic of Germany, Taiwan, South Korea, and Denmark also adopted TI Common Module FLIR systems for use on their armored vehicles.

Previously, because of the FLIR's high cost, TI had only received orders for tens of the systems each year. However, after introducing the Common Module FLIR, TI marketed



Figure 6-3. TI Common Module FLIR-equipped TOW sight (Source: TI).

thousands of systems a year. As the price sharply decreased, orders dramatically increased, and by 1998, TI had produced more than 30,000 FLIR systems.

Many are convinced that the company's commitment to IR technology—even when the odds were less than favorable—ultimately furnished the U.S. Armed Forces with a distinct military advantage. FLIR allowed them to see through the darkness and own the night.

6.4.2 NVL Common Module Development Perspective

NVL, like TI, also addressed the FLIR's prohibitive costs and formed a common module study team to find a way to significantly reduce their cost. The NVL common module study team developed the Universal Viewer concept to standardize subsystems and their interfaces. TI and HAC competed to define modular concepts, develop the modular subsystems, and build prototypical systems to demonstrate design flexibility, performance, and maintainability.

HAC, working more independently from NVL, adopted a novel serial-scan concept they had developed earlier. The implementation of the HAC system was similar, conceptually, to the FLIR shown in Figure 6-4. The concept used a row of detectors having approximately 26 elements in the horizontal direction. (Only four are illustrated in the figure.) All the pixels in a given row scanned the same portion of the scene,

but each pixel saw a given point at a slightly different time from the others. By appropriately delaying the signals from the pixels using analog delay lines—a process known as TDI—the signals could be summed to improve the signal-to-noise ratio. While each pixel dwelt only a very short time over a given scene point, summing the signals from a line of pixels effectively increased the dwell time. The unidirectional scan with blank retrace directly mimicked standard TV CRT display scanning. However, it required an exceptionally high mirror scan rate, approximately 60,000 rpm, to match the CRT's electron-beam scan rate, and that raised reliability issues. However, the HAC project emphasized the elegance of the direct interface with a CRT, as a featured part of its cost-reduction approach.

TI's approach was very different from that of HAC (Figure 6-5). It included a detector array with a single vertical column of pixels. The array was scanned horizontally at relatively low speed with a simple mirror, which produced a unidirectional scan with a rapid retrace. The mirror could be vertically dithered on alternate scans to provide for interlace to effectively fill the gaps between pixels. An LED array of the same configuration as the detector array produced a visual image using the backside of the scan mirror. The detector came in three configurations, 180x1, 120x1, and 60x1, to provide options for matching performance or cost requirements. The electronics module was modularized in the same way so that the number of electronics channels could be matched to the number of pixels.

Concurrently, with the development of the modules, NVL awarded parallel contracts to TI and HAC to develop thermal-imaging sights for the TOW missile. TI developed around its modules, and HAC developed around the serial-scan approach. The HAC system produced the more pleasing image because the process of summing all detector outputs together eliminated detector nonuniformity effects. The elements of the HAC TDI array were spaced far enough apart that each pixel had its own cold shield, which made the elements more sensitive than those in the TI parallel-scanned array where all detectors shared one long cold shield.

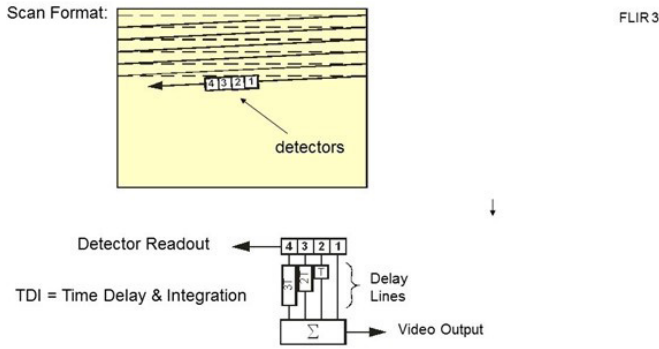

FLIR 3

Figure 6-4. Serial-scan FLIR concept of operation.

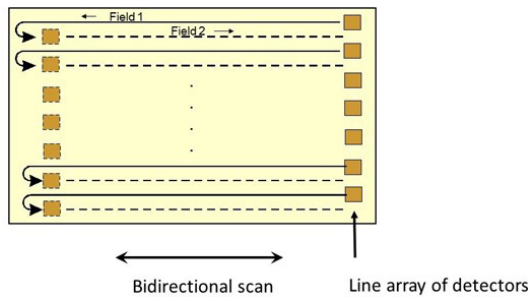

Figure 6-5. Parallel-scan FLIR concept of operation (Source: D. Schmieder).

However, the larger number of detectors in the TI array coupled with its lower noise bandwidth resulted in superior performance. The greater flexibility offered by the TI approach due to its robust, well-conceived modularity, increased its favorability. The Army NVL led the decision process, which probably had some bearing on the choice of the TI solution, as that solution was more favorable to man-portable and ground-vehicle applications, but less favorable to airborne applications requiring CRT displays.

6.4.3 Common Modules Description [46]

The common modules pictured in Figure 6-6 consisted of two mechanical modules, two optical modules, a detector/Dewar array, an LED array, and at least five electrical modules. There could have been more electrical modules if some electrical functions were removed and mounted on separate

printed circuit boards (PCBs) for packaging purposes. The cooler and mechanical scanner made up the two mechanical modules. The optical modules were the IR imager and the visual collimator. The detector/Dewar combination was a single module which converted IR light into an electrical signal. The LED array module converted detector electrical output into visible light. The five electrical modules were mounted on PCBs and included the DC/AC converter module to supply power to the cooler, the scan and interlace controller for the scanner, the bias regulator for the detectors, and the detector signal preamplifier and postamplifier modules. Sometimes there was an additional PCB which drove the LED array unless that function was combined with the postamplifier module. There was also an EO multiplexer TV camera, which was not generally considered one of the common modules but was essential when remote viewing was required such as for aircraft cockpit mounted displays. Of course all common module FLIR required a power supply but that was not a common module because the different tailoring options had different power needs. A brief description of each module follows Figure 6-6. Figure 6-7 shows the layout of a typical common module system.

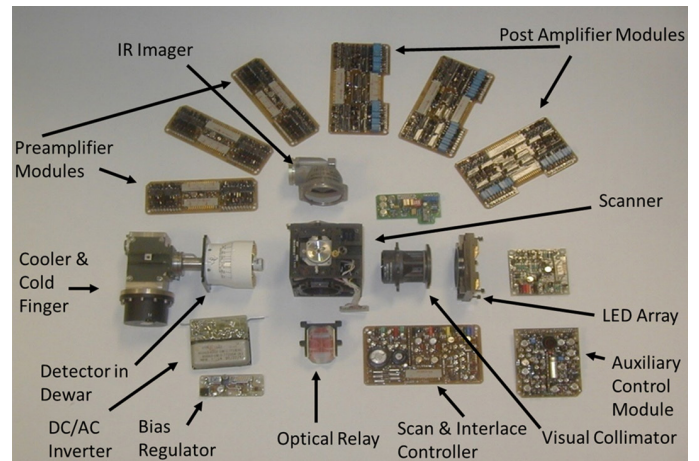

Figure 6-6. Set of common modules for man-portable FLIR configurations⁹ [46].

⁹ The item immediately below the scanner is an optical relay for the eyepiece for the TOW missile application, and it was not considered one of the common modules. The two unlabeled printed circuit boards (PCBs) were for TOW and may have been common modules at some point if some functions were removed from the other PCBs and mounted separately.

- a) **IR Imager.** Formed an image of the scene on the detector array. It was almost always used with one or more system-specific telescopes (afocal lens assemblies) to tailor the FLIR's magnification and FOV to the application.
- b) **Scanner.** Consisted of a two-axis gimbal and housing assembly. The inner gimbal was a two-sided mirror that simultaneously scanned the infrared image across the detector array and the corresponding LED visible output image for display. The outer axis allowed the mirror to tilt after each field to provide for interlace. A system-specific phase shift lens was also mounted on the outer gimbal so that, when light passed through it, it would shift the image slightly during field retrace to prevent electronic phase shift from causing a mismatch between the two optical fields in a frame.
- c) **Scan and Interlace Controller.** Drove the scan torque motor by providing scan mirror frequency and position servo control. It also drove the outer gimbal tilt solenoid, provided video gate signals, and accepted synchronization signals when used with an EO multiplexer.
- d) **Detector/Dewar.** Contained up to 180 photoconductive MCT detectors in a linear array sensitive to the 7.5–12 μm spectral region. Detectors could be tailored in groups of 60, 120, or 180 to match the application. The Dewar provided an insulated enclosure with a 75° cold shield cone angle.
- e) **Bias Regulator.** Supplied regulated bias current to the detectors, which were photoconductive, so their signal needed to be measured by sensing the change in resistance to the bias current caused by the incident photons.
- f) **Preamplifier.** Amplified the low-level signals coming from the low-impedance photoconductive detectors. Each module contained 20 parallel amplifier channels. Modules were added in parallel to match the number of detectors up to a maximum of nine for 180 channels.
- g) **Postamplifier (sometimes called Postamplifier/Control Driver).** Amplified the signals from the preamplifiers for input to the LEDs. Like the preamplifiers, each

module contained 20 channels, and up to a maximum of nine modules might be needed. The module accepted inputs from the auxiliary control module to control contrast, blanking, and brightness. Importantly, it also provided an adjustment for changing individual channel gain to achieve a uniform display. As an option, it sometimes was also equipped to drive the LED array as an alternate to a separate LED driver module.

- h) **LED Array.** Converted detector electrical signal to visible light using GaAsP diodes arranged in a format matching the IR detector array. It was normally driven by the postamplifier/ control driver module but may have had a separate driver module for that purpose.
- i) **Visual Collimator.** Collimated the emitted LED light. Since rays coming from the LEDs were diverging, they needed to be made parallel (i.e., collimated) to be viewed by an observer. The visual collimator was usually followed by system-specific relay and eyepiece optics to properly locate the image for observer access, diopter adjustment, and exit pupil size.

Auxiliary Control Module. Provided an interface between the external system control panel and the postamplifier module for contrast, brightness, and blanking. It also provided regulated supply voltages to the postamplifier module.

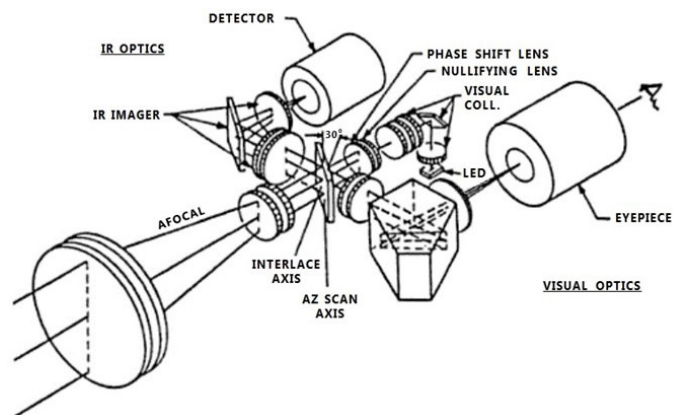

Figure 6-7. Typical layout for a common module FLIR [46].

Because TI would not sell the common modules to competitors, alternative sources for the FLIR common modules submitted proposals and were awarded contracts. Martin Marietta in Orlando, FL, received a contract for most of the modules, including the electronics, optics, cooler, and scanner. Honeywell in Lexington, MA, received a contract for the detector arrays, and Spectronics in Richardson, TX, received a contract for the LED array. Later, HAC developed the detector modules and LED array, at least partially on their own. Also, Magnavox became an alternate source for the cooler.

The availability of common modules increased the number of suppliers of military thermal-imaging equipment. Martin Marietta became a supplier, as did Kollsman, winning a substantial portion of the AN/TAS-4 TOW Night Sight production business. However, TI, HAC, and Honeywell continued in the thermal-imaging business.

Keeping the common modules "common" was a management challenge. Although all the companies producing modules began with the same data package, many of the modules also contained information proprietary to TI. The new sources had to use their own proprietary technological expertise to manufacture such items as the detector, Dewar, cooler, and LED array. This situation resulted in differences among modules manufactured by the various sources. However, at least initially, the differences were not apparent to system developers or to end users. NVL led configuration control.

A larger problem was the enforcement of the use of the common modules for new system developments. On 19 June 1973 the Joint Logistics Commanders (JLC) signed a charter to establish a Joint Technical Coordinating Group (JTCCG) for thermal-imaging systems. Its purpose was to study tri-Service coordination of R&D, procurement, and logistics. As a result, the JLC agreed to a tri-Service policy to use the common modules wherever possible, with NVL having responsibility for configuration control across the services. The charter became effective 15 July 1974. The JTCCG prepared a

Joint Services Development Plan for thermal imaging, and it included all ongoing and planned requirements.

Because common modules had been developed under the guidance of NVL (an Army entity), there were aspects of the modules that weren't applicable to their use by the other services. For example, in the use of the common modules for airborne gimballed systems, system requirements included minimal weight on the gimbal, but the modules were not designed to be separated from one another. Separation would have allowed some components to be removed from the gimbal thus reducing gimbal weight and size. In addition, the development of the "split-cycle" Stirling cryogenic cooler was maturing, and that provided a better solution for applications in which the sensor head had to fit into a small volume. It was better because the split-cycle cooler design removed the bulky (and vibrating) compressor stage from the expansion valve/cold-finger so that only the latter needed to be next to the detector array and on the gimbal.

Even within the Army there were difficulties. One of the difficulties was the generally understood independence of the project managers (PMs) within the services. They had long held to the understanding that their role was to look after the best interests of their office and their service branch. The coordination policy was in direct conflict with that long-standing practice. In addition to that, each contractor, looking for a competitive advantage, found ways to improve upon the original designs. There was a lot of pressure from contractors to implement proprietary features that would secure them future business on a given platform.

An important example of the diversification in the common modules was the XM-1 development, which led to the M1, the Army's main battle tank. It was developed under a policy that gave the prime contractor full responsibility for all subsystems. That policy was designed for enforceable accountability, but it violated the tri-Services agreement regarding use of the common modules. Up to this point, the Army Materiel Command (AMC) leadership had supported

NVL in its role of configuration control, but it was AMC that chartered the XM-1 PM to procure under the "prime contractor responsible" policy. As a result, the M1 thermal-imaging system differed from the common modules in regard to the detector, LED, visible collimator, bias board, and postamplifier modules.

A Joint Operating Agreement and associated procedures were drafted in 1977. The agreement designated a tri-Service Configuration Control Board (CCB) with the Army as chair and the Director of NVL as the Thermal Imaging System Common Module PM. According to the agreement, each service would have its own CCB to establish the position for that service prior to submission of any configuration change. PMs in the services were charged with developing procedures and for providing representation for the tri-Service CCB. This step required the Air Force and Navy to provide partial funding to the Army for managing configuration control, which they were reluctant to do, and which resulted in the new process never being implemented. Instead, the three services continued operating under the 1974 guidelines, under which the Director of NVL served as the configuration manager, the CCB was an Army-only approval authority, and the Army ultimately provided only data and guidance to the PMs under the Air Force and Navy.

NVL personnel were specifically assigned to support each major system PM. However, NVL was not separately funded to support configuration management, depending instead on funding from the PMs. NVL support was generally viewed favorably by the PMs, but the independence of prime contractors conflicted with NVL's configuration control authority. Often change requests were submitted hurriedly because of program schedule requirements, and justifications were inadequately substantiated. Delays, perceived to be bureaucratic, were not tolerable to the PMs, some of whom were senior military officers. There was also no preplanned product improvement (P3I) program in place to accommodate the progress necessary to satisfy evolving needs, although the expanding industrial base continued to evolve the technology.

As a result of all these factors, schedule and cost concerns of major systems overrode the configuration control process.

Nevertheless, the Common Module program and the modules themselves have to be considered a major success. Tens of thousands of FLIR systems were delivered at costs and production rates that could not have been realized without the common modules. Not only was acquisition cost reduced, but also the cost of ownership. However, the conflict between innovation and commonality eventually ended the Common Module era.

6.5 COMMON MODULE DETECTOR EVOLUTION [46]

Detectors for the common modules were the most important components of the FLIRs and the most difficult to fabricate. The detector modules employed photoconductive linear arrays of thin MCT sheets epoxied to sapphire carriers and delineated into individual detector elements. After fabrication, the easier step was to mount the resulting line arrays of 60, 120, or 160 detectors onto a glass stem of a Dewar where leads were brought to the vacuum interface/connector on gold traces that were laser scribed on the stem. Laser-trimmed bias resistors were located outside the Dewar to equalize gain on the detectors across the array. The Stirling cycle expander shaft of the cryocooler was inserted in the hollow stem to cool the detector array to LN₂ temperature.

As with many new technologies, MCT detectors were thrust into production too early, and so a crash manufacturing technology effort was initiated to get yields to the point where newly minted tanks and aircraft would have FLIRs to fill the hole in the skin. Through this period, some stakeholders continued to support extrinsic Hg technology in spite of the significantly lower operating temperatures, with the rationale that "MCT is the technology for the future... and always will be" and "HCT stands for high-cost technology." Although MCT was a dangerous and thermodynamically unstable material, it was an essential part of common module detector development.

6.6 SUMMARY OF GEN1/Common Module History

The success of IR detection, first in surveillance and later in fire control, led to a widespread demand for FLIRs and an approach to their affordability. TI recognized from their many customized parallel scan designs that most of the components were similar and that standardization was not only possible but desirable to maintain an advantageous business posture in a competitive business. The design simplicity, manufacturability, and elegance of the TI approach as well as its greater sensitivity won out in a competitive procurement. That procurement award decision was dominated by field performance test results on the Army's TOW ground-to-ground missile guidance unit. TI was understandably reluctant to share their technology but, in order to obtain true cost reduction, the Army recognized there had to be competition for the module assemblies. The Army therefore wrote specifications for the various modules and competed procurements. Competitors were not required to mimic TI designs because that would have infringed on TI proprietary information. However, they did have to meet performance, form, and fit specifications of the TI modules in order to qualify. The success of the Common Module program can be attributed to both the design concept and the management of the program.

"Mod FLIRs," as they were sometimes called, quickly demonstrated their worth in combat. The common module investment paid off during Operation Desert Storm, the Gulf war fought to eject Iraqi forces from Kuwait. Mod FLIRs on front-line weapon platforms such as the F-117 stealth bomber, the F-15 and F-16 strike fighters, the Apache helicopter, the M1 Abrams tank, the M2 Bradley APC, and the TOW missile launcher played a critical role in the successful operations against Iraq's infrastructure and its armored and mechanized units. The LWIR FLIRs gave U.S. pilots and gunners the edge as they found and attacked targets not only at night, but, because of their long wavelength obscurant penetration capability, they also were able to attack through burning oil clouds, battlefield smoke, and blowing sand.

It is estimated that the common modules effort brought down the cost of scanning thermal imagers from around \$250,000 to about \$50,000. TI licensed the technology to AIM in Germany, which continued to be a supplier well past 2010. As U.S. allies and non-allied forces acquired thermal-imaging capabilities, the U.S. advantage diminished. The need to keep ahead of the threat and the emergence of new microelectronics capabilities led to the development of a second generation (GEN2) of FLIRs based on GEN2 detectors formatted into focal-plane arrays (FPAs). Their history is described in Chapter 7.

CHAPTER 7. GEN2¹⁰ FLIR: READ-OUT INTEGRATED CIRCUIT (ROIC) INVENTION AND SELF-SCANNED FPAS

7.1 INTRODUCTION¹¹

Chapters 7, 8, and 9 address the development of GEN2 FLIRs as follows:

- The invention of analog multiplexers called ROICs, which are on-focal-plane analog multiplexers of multiple detector outputs. (Chapter 7).
- The development of photovoltaic MCT detector arrays (Chapter 8).
- The mostly concurrent development of photovoltaic InSb detector arrays and, later, uncooled microbolometer detector arrays (Chapter 9).

In the early 1980s, Common Module FLIRs were widely adopted in U.S. ground armor, tactical aircraft, ships, and man-portable weapon systems. However, FLIRs were still a novelty to the public. For instance, nightly news broadcasts would often show the "amazing" ability of FLIR-equipped weapon systems to see at night without relying on moonlight, starlight, or any artificial source of illumination. Schmieder was interviewed by an Atlanta TV station in 1980 and was asked to show their audience imagery from the new Apache attack helicopter TADS (Target Acquisition Designation System) FLIR, which he helped design. Permission was obtained from the Army to do so. This kind of interest and visibility was not unusual either at home in the U.S. or in other countries. However, to militaries around the world, it was obvious that FLIRs were not just a novelty but were an

essential tool on the modern battlefield and no military could compete without them. It was also obvious to many that, as with any technology, the current status of FLIRs was subject to the inevitable changes of technological progress.

Accordingly, at least two motivational trends were developing. First, the fact that other countries could see the advantage of having FLIR-enabled night operations and wanted it for their militaries, put pressure on the United States to maintain its technological edge. Secondly, progress in microelectronics was evolving rapidly and was impacting the design and application of existing military and civilian electronic devices. Moreover, they offered the possibility of introducing whole new applications not yet envisioned. This progress put more pressure on the U.S. to exploit it to maintain its lead in FLIR technology. Thus, the incentive and the tools were there for the U.S. to maintain its leadership.

FLIR technology had been paced by detector technology. However, while continuing detector development was still crucial to progress, GEN2 FLIR development was now also paced by progress in microelectronics, especially in both analog multiplexing implementations and photolithographic feature sizes. For instance, early FLIR developers understood the importance of adding more detectors to the focal plane to increase sensitivity and other benefits. Increasing the number of detectors by a factor of two means doubling the signal, but noise doesn't double; it only increases by the square root of 2 because, since noise is uncorrelated, it adds in quadrature (the square root of the sum of the squares). Accordingly, sensitivity increases by the square root of the number of detectors, a very significant increase. So, it was very compelling for FLIR designers to determine how to add as many detectors as possible to the focal plane.

Mitigating against more detectors, however, in the days of GEN1 FLIRs with discrete detectors, was the need to add a

¹⁰ "GEN2" terminology is often used to refer specifically to the Army's scanned linear arrays that employ GEN2 multiplexing and photovoltaic detector technology, but the more expansive definition that refers to all FPAs, scanned and staring, with such technology is used in this book.

¹¹ This chapter is largely based on Georgia Institute of Technology Professional Education course notes from *Infrared Technology & Applications* [1].

preamplifier and a postamplifier together with their associated support equipment for every detector channel added. Moreover, each additional detector added greater heat load on the cooler because of the bias current flow required by photoconductive detectors. In addition, another wire had to be taken out of the Dewar, and the thermal conduction of that wire increased the cooler heat load even more. But just from packaging considerations, it was only practical to package 20 amplifiers on a nominal 25-in.²-circuit board, and so nine circuit boards were required for all the preamplifiers, and another nine were required for the postamplifier when a GEN1 FLIR was configured to use all 180 detectors. Clearly a system would quickly run out of room if many more detectors were added. Finally, the combination of additional detectors, their drive electronics, and larger cooler would require more power and a larger power supply. It was no wonder that GEN1 FLIRs stopped with 180 detectors.

Advances in microelectronics for on-focal-plane multiplexing provided a way to decouple the detector count from the channel count. That advancement, in turn, motivated the development of photovoltaic diode detectors to greatly reduce the heat load and provide high impedance compatibility for easier integration with the multiplexer. Together, both advances enabled the focal plane to handle, at first, tens of thousands of detectors and eventually millions of detectors.

The emerging GEN2 IR detectors provided large, 2-D FPAs in both staring and scanning formats. Sensitivity rose dramatically, and smaller feature sizes allowed the detector dimensions to be cut roughly in half to improve resolution. While this detector size reduction reduced sensitivity by the same amount (i.e., by the square root of the detector's area reduction), overall sensitivity still increased dramatically due to the higher detector count. Moreover, the smaller detector dimensions allowed for shorter focal lengths, and that both recouped the sensitivity loss imposed by the smaller detectors (because the f-number went down) and reduced package size and weight. Alternatively, for some applications, the focal lengths could be made longer because now the FLIRs could also be made with higher f-numbers (trading improved detector sensitivity for less efficient collection

optics). This increase in focal lengths reduced the detector's angular subtense and placed more detectors on a target. The result was improved resolution, greater stand-off range, and improved crew survivability. These improvements occurred because, after a certain sensitivity level is achieved, resolution becomes the dominant performance metric since target acquisition range scales directly with resolution in a clear atmosphere. GEN2 sensitivity improvements indirectly enabled that resolution improvement. The combination of multiplexing, more sensitive detectors, and smaller detector dimensions resulted in revolutionary GEN2 FLIR advances.

Detector advances were clearly still essential to GEN2 FLIR development. With a large increase in the number of detector channels now possible, FLIR designs could no longer use photoconductive detectors. Such detectors had low impedance and required a high bias current that resulted in large power dissipation on the focal plane with attendant increased cooler heat load. Accordingly, multiplexers motivated the development of photovoltaic detectors since their high-impedance p-n junction greatly reduced the required bias current and heat generated. Moreover, photovoltaic detectors brought the additional benefit of having greater inherent sensitivity. However, given the difficulty of making MCT detectors at all, now the requirement to make them with notoriously finicky p-n junctions was a major challenge that had to be overcome. While that problem was eventually solved in MCT, it was also responsible for maturing InSb as an alternative, or for some applications, an even better detector candidate.

Even more consequential was the development of uncooled, room-temperature detectors based on an entirely different "thermal" detection mechanism that replaced photon quantum detection with temperature-change detection. The latter then led to microbolometer and pyroelectric-based detectors. Thermal detectors had been invented many years before, but they had too little sensitivity to provide many practical applications. Now, however, the increase in sensitivity made possible by multiplexing hundreds of thousands of detectors assembled together in a single FPA made thermal detectors feasible for many applications. Furthermore, their

low cost enabled applications that were not affordable with cooled photon detector-equipped FPAs. The remaining sections of this chapter discuss the history of the various approaches taken to develop focal plane multiplexers, or ROICs, as they were called. But these sections also describe the advances made in detectors to both accommodate them and take detector technology to the next level. Together they chronicle the GEN2 FLIR development.

7.2 SPRITE DETECTOR INVENTION

Before clock-driven analog multiplexing techniques became the baseline approach to second-generation FPAs, a clever approach was invented in the U.K. that arguably might have qualified it as one of the first GEN2 devices. Since the benefits of high detector count were widely appreciated, there were various attempts to solve the detector access problem. One of the first attempts was the use of TDI in which the output of any given detector was delayed and summed with the output of a following detector as described previously in Section 5.4.3 for the HAC Discoid Serial Scan FLIR. However, with only bulky analog electronics, delay lines, and many discrete components, that task was difficult. Later, in the mid-1970s, the U.K. was trying to come up with their own version of a Common Module FLIR to duplicate the successful U.S. Common Module FLIR program. Tom Elliot, while at the British Defense Ministry's Royal Radar Establishment (RRE), Malvern, later renamed QinetiQ, realized that TDI could be accomplished inside a single, extended, monolithic, photoconductive detector to make it appear to be many more discrete "virtual" detectors [32, 47]. The resulting serial output could then be coupled to a single amplifier circuit, thus effectively multiplexing the virtual detectors together. Some called his invention TED (for Tom Elliot's Device), although the official name for it was Signal Processing in the Element (SPRITE). Figure 7-1 illustrates how it worked.

The detector's bias voltage was chosen so that photoelectrons, formed from a scene pixel, drifted at the same rate the image was being scanned. Accordingly, photo charges accumulated and remained registered with the same scene pixel across the whole detector. When they reached the end,

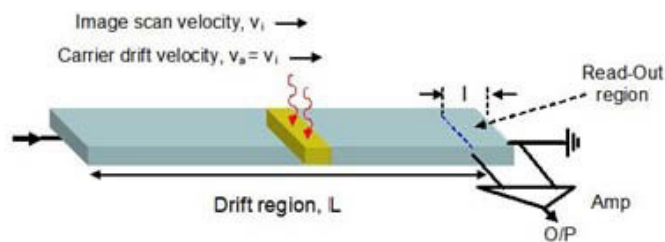

Figure 7-1. SPRITE Principle of Operation: Detected photoelectrons are made to drift at a velocity that matches the image scan rate to effectively implement TDI (Source: Elliot [32] and British Defense Ministry, RRE).

they were read out with a preamplifier. Early versions made in 1975 were $50\ \mu\text{m}$ wide by $1,000\ \mu\text{m}$ long and so appeared to make it possible to have 20 virtual detectors contained within its length. However, charge diffusion resulted in an effective individual detector length of about $75\ \mu\text{m}$, or more, so this approach did not achieve the same resolution in the scan direction as was obtained by using discrete detectors. By 1980, arrays were built for parallel-serial scanning with eight detectors each of $800\ \mu\text{m}$ by $75\ \mu\text{m}$. The latter configuration would thus effectively provide a total of about 8×10 elements in an 80-element array while using only one preamplifier and one postamplifier. An equivalent 80-detector U.S. GEN1 FLIR, for example, would have needed four 20-channel preamplifier PCBs and four 20-channel postamplifier PCBs plus a much larger power supply. So the U.S. GEN1 FLIR would have required a much larger package.

SPRITE detectors were the basis of U.K. GEN1 Common Module FLIRs, although they might have qualified as second generation. The SPRITE-based U.K. common modules provided high sensitivity and high-quality imagery in a very compact package. Various versions were built and, by 1999, over 3,500 FLIRs were made based on the Class II configuration alone. They were used in the Falklands conflict and in the two Gulf Wars.

7.3 MULTIPLEXER ROIC DESIGNS

7.3.1 Charge Coupled Device (CCD)

The invention of CCDs in the late 1960s by Smith and Boyle at Bell Labs [48] made it possible to envision GEN2 FLIR detector

arrays which could be coupled with on-focal-plane electronic analog signal readouts. As envisioned those readouts could hopefully multiplex the signal from an exceptionally large array of detectors. CCDs were easy to fabricate in silicon, and the high purity of silicon provided high yields. Figure 7-2 illustrates their operation.

Importantly CCDs use neither photoconductive nor photovoltaic detectors. Instead they employ a new technique that uses a metal-insulator-semiconductor (MIS) structure. The MIS structure, as its name implies, is a three-layer sandwich consisting of a metal layer on top of a silicon oxide insulator layer, all on top of a semiconductor layer. The bottom semiconductor layer converts impinging photons, here incident from the bottom, into electrons using the photoelectric effect. This structure acts like a capacitor.

A CCD exploits the MIS structure by making the semiconductor and insulator layers into a long, narrow, continuous detector. It then covers it with a linear array of discrete metal pad electrodes in which each pad is sequentially connected to one of three time-varying, clock-driven voltages. This is called a three-phase CCD and is the type shown in Figure 7-2. Two-phase CCDs are possible as well and they only use two clock phases connected to two pads. Clock-driven voltage variations on the metal pads create potential wells under

the insulator, which attract the photoelectrons and form charge packets. Each pixel site is defined by the driver pads; thus, a single, three-phase CCD pixel consists of three metal pads. The voltage waveforms supplied by the three-phase clocks result in the maximum potential occurring under only one pad, of the three, at one time. Hence, the charge packets form only under the pad having the highest voltage potential. This arrangement also isolates each pixel from their adjacent pixels. However, since the clock-driven voltage waveforms vary in time, the voltage under the second pad is timed to exceed that under the first pad. When this happens, the charge packet "rolls" from the first pad to under the second pad. A repetition of this process makes the packets roll together, unmixed, down the line of pads, for an indefinite length and pixel count, until they are sensed at the end of the line. The result is a sequential (serial) readout of the whole line of charge packets.

CCDs quickly replaced film and bulky vidicons as the preferred sensor in commercial and consumer video and snapshot cameras. It was soon evident that CCDs could be used to make solid-state, "self-scanned" devices that could be useful for memory and other applications as well as imagers. However, a major impediment for FLIR application was the difficulty of building these devices out of the more exotic materials required to detect longer-wavelength IR photons. A breakthrough occurred with the discovery that Schottky-Barrier photodiodes, made from a layer of platinum deposited on silicon, was found to respond over the 1–5- μm region. This discovery resulted in one of the first production GEN2 FLIRs, when a Schottky-Barrier CCD made from platinum silicide (PtSi) was used as the FPA for B52 bombers. These devices were attractive because they were "monolithic," meaning they could be fabricated by depositing multiple material layers sequentially on a single substrate. However, PtSi response to MWIR photons was poor and provided a quantum efficiency of only about 1%. A more exotic material would have to be used if higher quantum efficiencies were to be attained, but the microelectronics industry's capital base and material handling expertise were invested in high-purity silicon. That capability did not easily transfer to other, lower-purity

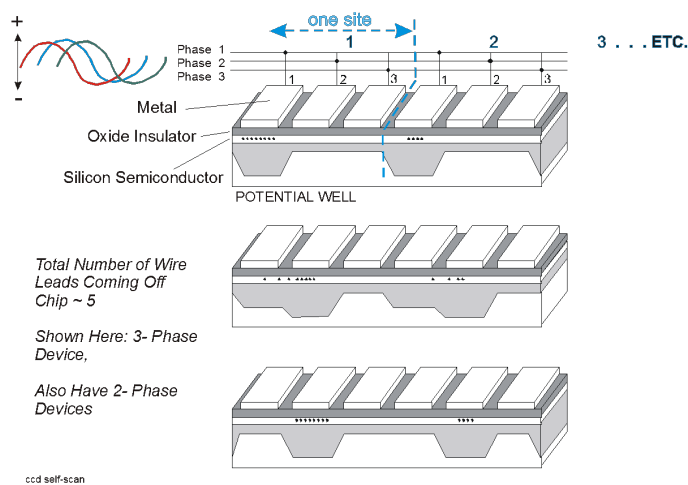

Figure 7-2. CCD Operation (Source: Georgia Tech ITA course notes [1] as adapted from Amelio [48], 1974).

materials such as those required for IR detection. It soon became apparent that the detectors would have to be made separately on one type of material, but the multiplexer would have to be made from lower-cost, higher-yielding silicon. The combination would then have to be bonded together in a "hybrid" configuration to form an electronically scanned IR FPA. The multiplexer half of this device became known as an ROIC. ROIC designs were the key to GEN2 FLIR technology. Eventually, CCD ROICs were replaced by other types of ROICs with better features.

7.3.2 Charge Injection Device (CID)

Another multiplexing device, the CID, was invented in the early 1970s, shortly after the CCD. GE invented this technology while working to design memory chips, but it was soon adapted to imaging applications as well. Figure 7-3 illustrates its operation. Photoelectrons accumulate in capacitive wells formed under the intersection of each row and column. Conventional shift registers are used to position a voltage at any desired x and y location. The x location, for instance, places that voltage at every site on the x-column of sites. Likewise, the y-location places that voltage at every site on the y-row of sites. Each site has an x and y pad. When not addressed,

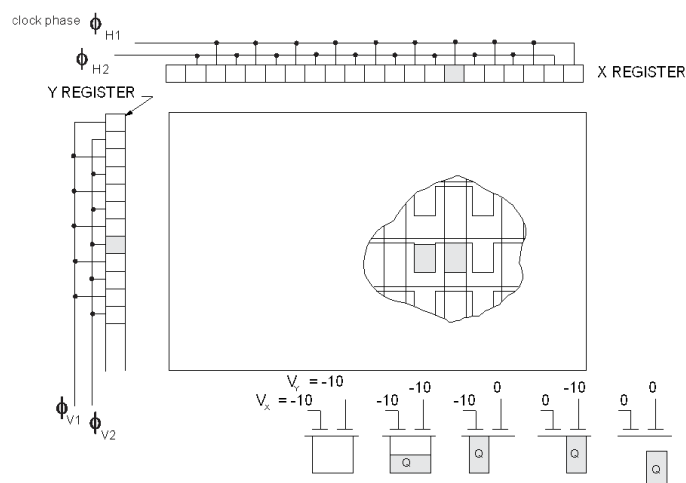

Figure 7-3. CID Operation (Source: Georgia Tech ITA course notes [1]).

each pad is held at a suitable negative voltage, which allows photo-induced charge (here positively charged carriers, or holes) to collect under the pads. When a pad is addressed, the negative voltage condition is canceled, and the charge collects under the other pad. If the voltage is removed from both wells, the charge is injected into the substrate where it is sensed as a current or voltage change, usually by an on-chip preamplifier. Since the particular x and y address of each charge is known, the detected output is a "video" signal. This technique differs from that of a CCD in that the pixels can be accessed either sequentially as is required in a CCD or randomly since sequential access to CID pixels is no longer needed.

One advantage of a CID is that it can be used to "window" smaller regions of an array to use a higher frame rate or lock out undesired regions of an image. Another advantage is that it mitigates blooming from bright sources because the structure offers no ready path for excess charge to overflow into adjacent pixels. A disadvantage of CIDs is that the cell capacitances are all in parallel, whereas in CCDs, the capacitances of each cell are isolated, so Johnson noise (proportional to capacitance) is much greater in a CID. However, background shot noise is so dominant in FLIRs that the internal noise in a CID ROIC is typically small in comparison. Both CCDs and CIDs have the disadvantage of not being able to use all of their surface area for charge storage since both require empty adjacent wells to keep the pixel charges separate. This requirement reduces the maximum charge they can store and limits their dynamic range. That is an unfortunate feature of both multiplexers since large storage capacity is required for charge storage devices when working in the IR because the high background pedestal¹² of IR scenes leaves little room for signal storage. This limitation was overcome by the invention of a metal-oxide-semiconductor field effect transistor (MOSFET) switch technology, which is described in Section 7.3.3.

¹² The term "pedestal," sometimes just called "background," refers to the fact that typical scene temperatures are near 300 K, but object "signal" is the difference between the object's temperature, say 302 K, and the 300 K background. So that background temperature makes the object look like it is riding on a pedestal. Most photoelectrons in a staring detector are obviously due to the pedestal, i.e., background flux. This pedestal flux is undesirable both because it uses up most of a staring detector's storage capacity and because that background contains quantum noise.

7.3.3 MOSFET Switch

The MOSFET switch was the third and last major multiplexer type as well as the one that became the most used of the three. These devices were often just referred to as simply "CMOS" (complementary metal-oxide-semiconductor) multiplexers after the basic CMOS architecture used in integrated circuits from which they were derived. CMOS devices were invented in the early 1960s at Fairchild Semiconductor and were widely adopted for integrated circuit design because they offered high noise immunity and low static power consumption.

To better understand MOSFET switch FPA multiplexers, it is helpful to understand what a MOSFET is and can do. It is a type of transistor with a current input node, a control gate node, and an output drain node as shown in the Figure 7-4 side breakout where the input node current comes from the detector's integrating capacitor. A voltage on the gate controls the flow of current through the gate region to the drain. The gate region is often referred to as the "pinch-off" region because selection of the proper voltage on the gate can either pinch-off the flow of current or allow it to proceed. Thus, it can operate as a simple switch. But it can also operate as

a current amplifier in the sense that a small gate voltage can control a large current flow. Likewise, it can be converted into a voltage amplifier by passing the current through a resistor since the voltage across the resistor will change with a change in current flow. Finally, the MOSFET can be made to perform AC coupling by inserting a bias voltage on the gate to change the level at which current can flow. Adjusting the bias above the DC level removes all but AC variations. The MOSFETs can be made to do other functions too, but those described here are most helpful in understanding their roles in MOSFET switch FPAs. As its name implies, the MOSFET switch multiplexer was developed from an array of MOSFETs. An example arrangement is shown in Figure 7-4.

The MOSFET switch multiplexer was organized much like the CID shown in Figure 7-3 with each pixel accessed by a row and a column connected to a vertical and a horizontal shift register, respectively. However, it differed from a CID in that each site consisted of a MOSFET switch along with the detector. The detector formed the MOSFET's photoelectron charge storage capacitor. But instead of injecting charge, the MOSFET switched the charge out of the site into the column shift register. Access to stored charge was gained only when

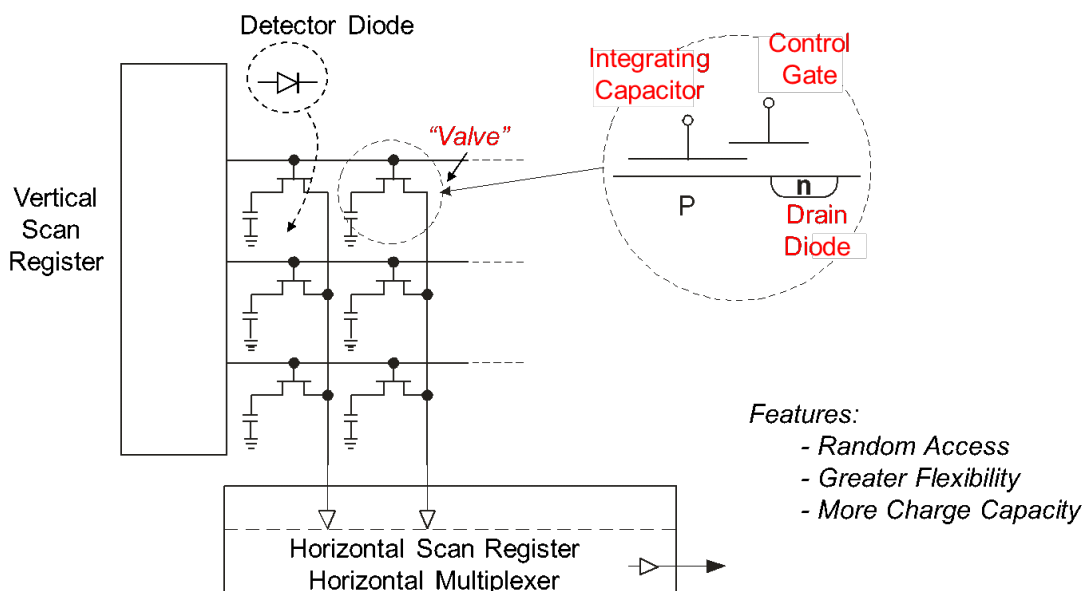

Figure 7-4. MOSFET switch device architecture (Source: Georgia Tech ITA course notes) [1].

the gate and drain contacts were simultaneously closed by the row and column address lines. These devices shared the random-access feature of a CID but, unlike either CIDs or CCDs, were able to use virtually all of the cell's surface area for charge storage thus doubling storage capacity. (Note that the surface area required for MOSFET feature sizes was so much smaller than the detector cell's active area that they virtually had no effect on the available surface area for photodetection.) Moreover, the architecture was convenient for adding more functionality to a site's MOSFET switch such as inserting a separate switch and access port for controlling charge integration time so that it was independent from the device's frame rate. This additional functionality was an important feature when, for instance, a FLIR needed to avoid cell saturation in viewing warm backgrounds or by accommodating more efficient collection optics by using a shorter integration time. It was also very useful when needing short integration times to minimize image smearing with electronic motion stabilization schemes. This flexibility, combined with the wide adoption of basic CMOS fabrication by the broader microelectronics industry, made the MOSFET switch the preferred multiplexer for FLIR FPA ROICs.

7.4 DEVELOPMENT OF GEN2 SELF-SCANNED FPAs

The invention of ROICs resulted in the emergence of self-scanned FPAs. ROICs were combined with detector arrays in various ways to mate the detection function with the read-out and multiplexing function to provide a serial output. That output needed to be compatible not only with standard displays but with various signal processors that worked best, in that era, on serial information such as trackers and automatic target recognizers. However, once ROICs were developed, their mating with detector arrays took different routes that depended on the various ways to both mechanically and electrically connect them. The challenge was to develop detector designs that were able to solve read out compatibility issues. These issues included charge storage limitations with high background flux, interconnection strategies for biasing the detectors, and signal access and grounding circuit designs for inserting the detector signal charge into

the ROIC. Most importantly, the challenge in FPA design included how to handle the large thermal mismatch between the more exotic materials needed to detect IR photons with the more common materials needed to make the ROIC such as silicon or GaAs. The problem was the different coefficient of thermal expansion (CTE) between detector materials and ROIC materials, which tended to cause separation when fabricated and stored at room temperature, but then operated and repeatedly cycled on and off to cryogenic temperatures. The next two chapters describe the history of FPA development first for cooled MCT (Chapter 8) and then for cooled InSb and other types such as room-temperature FPAs (Chapter 9).

CHAPTER 8. GEN2 FLIRS WITH COOLED MCT DETECTORS

8.1 INTRODUCTION¹³

Since MCT was the leading detector material for FLIR FPA application leading up to GEN2, it was also initially the leading material candidate for GEN2 technology. However, InSb was largely developed in parallel with MCT and was used in the eventual design and fabrication of the largest formats employed in IRFPAs. While the application to InSb is the focus of the next chapter, many comments regarding GEN2 applications to InSb are also covered in this chapter.

8.2 DEVICE STATUS IN THE EARLY 1980s

By the early 1980s, it was possible to build an amplifier-integrator in silicon and couple it with an IR detector: GE invented the CID (later adopted at Northrop and TI) and applied it to FPAs. HAC and TI implemented CCDs to permit integration and multiplexing on detector arrays. The first 2-D arrays with more than 10,000 detector elements were InSb arrays with silicon CIDs at GE. Meanwhile, TI maintained their totally "monolithic" MIS approach in MCT, so they fabricated both the CCD multiplexer and the detector from MCT. That approach put them at a temporary disadvantage in the development of GEN2 FLIRs due to the difficulty of working with MCT.

Among the most significant events in FPA development were the demonstrations of the indium bump interconnect at HAC SBRC and the via-hole interconnect at TI (also at Mullard in the U.K.). They provided a way to connect the dissimilar detector materials with their silicon readouts. These developments moved charge integration to the silicon multiplexers and quickly eclipsed the capabilities of the monolithic MIS

devices. This advantage resulted from the higher dynamic range (well capacity) of silicon as opposed to that of MIS capacitors made from the narrow-gap semiconductor detectors. The result of this progress was the introduction of the now widely used "hybridized" IRFPAs, which connected silicon multiplexer arrays with dissimilar detector arrays.

Note that at a very early stage, the Air Force approached GE in Syracuse, due to their proximity to Professor Henry Levinstein's IR materials group at Syracuse University, with an offer to become a center of excellence for IR detector technology. GE respectfully declined, as they could see little profitability in IR components, and so the Air Force chose HAC as the focal point for IR development. As a result, GE lost an important opportunity to play a larger role in IRFPA development.

The first advanced IRFPAs in limited (U.S.) production were InSb diode hybrids from HAC SBRC. This technology was principally developed through classified contracts from Lockheed Space in Sunnyvale, CA, and was employed in Cold War surveillance sensors. These early hybrid FPAs from SBRC eventually established InSb as a detector material of choice for Air Force and Navy longer-range airborne applications. The InSb mid-wave response was more desirable for the Air Force and the Navy because of improved diffraction-limited resolution and greater atmospheric transmission. MCT's long-wave response was preferred by the Army since their targets were engaged at shorter ranges but often required greater obscuration penetration to deal with battlefield smoke and dust.

The difficulties associated with the development and transition to production of the GEN1 Common Module family of detectors created the impression that MCT was a high-cost technology, and so the proposed move to second-generation FPAs, where the detectors would be photovoltaic diodes rather than photoconductors, was viewed with skepticism. Ways to grow uniform, low-defect-density MCT over large

¹³ This chapter is based mostly on extracts from Steve Jost's documents written for SENSICAC by request in 2013 [20]. Jost worked for just one organization, initially GE, during this period, but that same organization was purchased and managed in succession by Sanders, Loral, LMCO, and BAE.

areas, and then use it to create detector diodes, were needed to achieve the desired performance and low cost. Solid-state recrystallization, which had been employed for the Common Module effort was replaced by liquid phase epitaxy (LPE). With LPE, substrates of cadmium telluride (CdTe) or cadmium zinc telluride (CdZnTe) were immersed in either Te-rich or Hg-rich melts, and MCT films were precipitated out of the melt by controlled cooling. Molecular beam epitaxy (MBE), metal organic chemical vapor deposition (MOCVD), and isothermal conversion were also employed. But due to the relative maturity and low defect densities, LPE dominated.

8.3 MID-1980s FPA DEVELOPMENTS

As the mid-1980s approached, HAC SBRC's double-layer heterostructure¹⁴ diode was chosen over Honeywell's and Rockwell's ion-implanted homojunction MCT diode to become the LWIR detector design of choice in the United States. TI pursued an LWIR MIS technology that was initially chosen for the Javelin seeker and Command Launch Unit. When the Javelin seeker contract was transferred to HAC, TI took what they had learned from MIS and developed a competitive alternative to the double-layer heterostructure.

In the meantime, the Navy was looking at the MWIR band, as explained in Section 8.2, to provide improved resolution with smaller apertures and for better atmospheric transmission. MCT could be tuned to the MWIR band, but InSb was used due to its level of maturity and significantly lower cost. Amber Engineering cemented InSb's dominant role in staring technology by introducing an inexpensive (\$49,999) 128x128 camera engine in the mid-1980s. Prior to this lower-cost camera, a similar format custom MWIR FPA would cost between \$430,000 (GE InSb CID) and \$1.2 M (HAC MCT). Since that time, Amber, CE, FLIR Indigo, Santa Barbara FPA (Figure 8-1), and HAC SBRC produced many hybrid InSb FPAs on silicon MOSFET switches but HAC/Raytheon (Raytheon

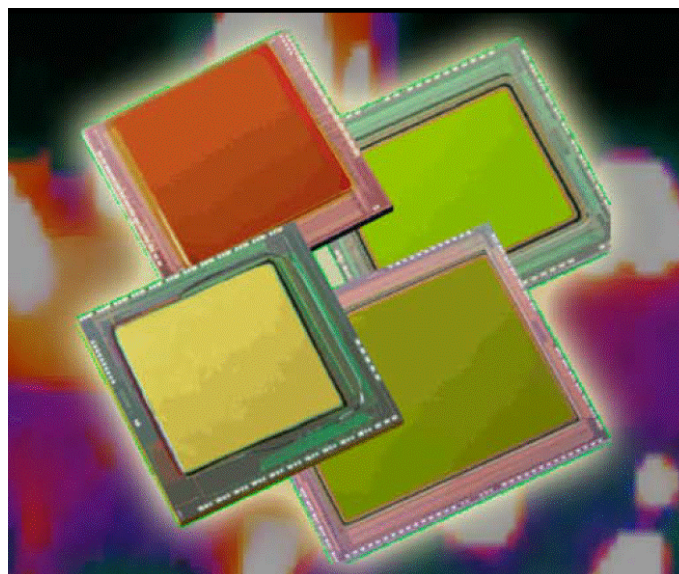

Figure 8-1. Several InSb FPA formats from Lockheed Martin Santa Barbara Focal Plane. Navy and Air Force staring FLIRs for targeting and navigation employed InSb FPAs in 480x640 format or larger. InSb dominated the large-format staring market with excellent performance at a reasonable cost (Source: Lockheed Martin Santa Barbara Focal Plane).

acquired HAC in 1997) dominated the military production of these FPAs.

Rockwell identified substrate availability and size as the principal cost drivers for MCT diode arrays and developed a producible alternative to CdTe epitaxy (PACE) where they grew modest-quality, single-crystal CdTe on sapphire by MOCVD followed by an MWIR LPE MCT process. By going to 3-in. sapphire substrates, Rockwell probably held a temporary cost advantage over their MCT competitors but failed to take the market away from InSb detectors, which required no epitaxy (matching of crystalline lattice structure) and offered similar wafer sizes. A significant investment was made in a similar technology for LWIR diodes, PACE II, where GaAs wafers served as the substrates, but the state of hetero-epitaxy (growing crystals of one material on the crystal face of another substrate material while maintaining the lattice

¹⁴ A heterostructure is a combination of heterojunctions where a heterojunction is the interface between two layers of dissimilar crystalline semiconductors that have unequal band gaps. A homojunction, in contrast, has two layers of similar material with equal band gaps but has different doping. In both hetero-junction and homojunction types, the interface is formed between an n-type and a p-type semiconductor to form a p-n junction. In a double-layer hetero-structure, a narrow-bandgap material is sandwiched between two wide-bandgap layers. In the case of MCT, the narrow-gap material, needed to absorb in the LWIR, can be surrounded by wider-gap material to prevent instabilities in the weaker, narrow-gap bonds.

structure and orientation identical to the substrate) for LWIR MCT in the United States did not equal the quality of competing technologies. This approach was eventually abandoned, although it was later resurrected.

Rockwell continued extrinsic¹⁵ silicon technology development and addressed the low quantum-efficiency issue by developing a clever detector structure where a layer of highly doped silicon provided enhanced absorption, and low dark currents were maintained with an undoped silicon "blocking layer." These blocked impurity band detectors still required more cooling than their narrow-gap semiconductor counterparts but pushed the competition to better uniformities. Perhaps the most expensive FPA ever built was based on extrinsic silicon technology: the "Teal Ruby" FPA.

During this period, Amber had become a merchant supplier for silicon ROICs, an increasingly important FPA component. GE, Litton, Martin Marietta, NERC, Rockwell and others all demonstrated second-generation FPAs that incorporated Amber designs. Once a competitive detector process was established, the readout became a significant discriminator.

8.4 MCT TECHNOLOGY TRANSFER FROM THE FRENCH

Difficulties with p-n junction photovoltaic diode fabrication presented an even greater challenge in MCT compared to the already difficult task of even making photoconductive detectors given the problems of working with MCT. A significant aspect of that difficulty was the need to passivate the detector surface after the junction was made. A detector needed surface passivation to be stable chemically, electrically, and thermally. Generally, this passivation required a surface coating that had a high electrical resistivity to avoid leakage currents and provided a good lattice match to avoid strains and flaw generation. Of course, the passivation material was also required to transmit well in the detector's spectral passband and potentially meet all the other requirements

simultaneously with both p- and n-type material depending on the device's configuration. Typically, detector manufacturers struggled to find a satisfactory working solution and, if they did find a solution, they naturally wanted to keep it proprietary.

For competitive reasons and the unavailability of LWIR MCT FPAs for sensor development, both GE and McDonnell Douglas licensed the French diffused MCT technology from the company SAGEM. This was the first production MCT diode technology with CdTe passivation. Before CdTe gained acceptance in the United States, many surface passivation materials were tried: anodic oxide, silicon oxide, zinc sulfide, and a range of organics such as epoxy. TI employed a biased gate, which controlled the surface potential and leakage currents; in spite of the extra processing required, it worked better than most surface passivation materials, but the French innovation prevailed.

As with any technology transition, there were aspects of the diode process that were not completely understood or appreciated. This lack of understanding, coupled with the language problem, complicated the transition to GE's laboratory in Syracuse.

Eventually, GE succeeded in manufacturing competitive scanning arrays, and they were incorporated into the first advanced U.S. LWIR MCT FPA production sensor, the Navy F-14D IRST (Figure 8-2). The significance of this success was the U.S. validation of CdTe passivation, which is now employed by the entire detector community even though McDonnell Douglas and GE were the only U.S. companies to license this critical technology from SAGEM. The GE team worked with both TI/DRS and Honeywell/Loral/Lockheed-Martin/BAE Systems in the development of their own CdTe passivation formulations. Without CdTe passivation, production MCT diode technology may not have been possible.

¹⁵ An extrinsic semiconductor is one that has been doped with trace elements of other materials to enhance certain properties as compared to an intrinsic semiconductor, which uses no foreign materials.

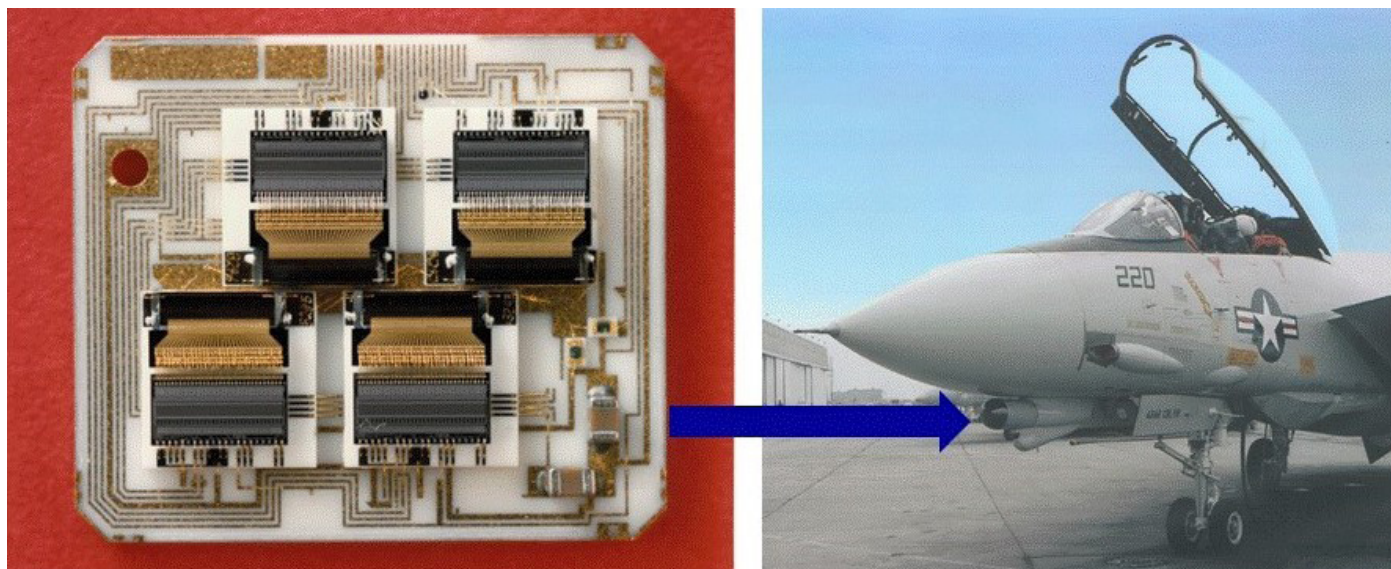

Figure 8-2. The F-14D IRST FPA consisted of four 64-element modules of LWIR MCT diodes and an Amber/GE designed readout. This was the first production LWIR diode-based FPA in a production U.S. sensor, circa 1991 (Source: General Electric).

TI pursued an LWIR MIS technology that was initially chosen for the Javelin seeker and command launch unit (Figure 8-3). Due to the high biases required to maintain acceptable dynamic range, the tunnel currents in the LWIR devices reduced FPA yield to near zero in spite of the fact that the prototype seekers had an excellent track record for hitting armored vehicles. This result may have been a case of over specification, but the low FPA yields caused significant concern at high levels in the Pentagon and almost caused the entire Javelin program to be cancelled. The Javelin seeker program was the first high-volume, advanced FPA production effort in the United States.

As a result of the low FPA yields, the Javelin seeker FPA contract was transferred to HAC. But TI took what they had learned from MCT MIS and developed a competitive, alternative FPA design to the HAC double-layer heterostructure design. TI developed this alternative with a mix of intrinsic and extrinsic doping in LPE MCT. Because of the demands placed on material perfection to minimize tunneling in LWIR MIS MCT, TI had developed what was arguably the lowest dislocation density MCT. This development translated into high diode yields with excellent uniformity.



Figure 8-3. The Javelin antiarmor missile has a staring seeker 64x64 LWIR FPA from Raytheon Vision Systems (RVS [HAC]) in the missile and a scanning sensor with a linear LWIR FPA from DRS (TI) in the command launch unit. The target is acquired with the command launch unit FLIR, which relays that information to the seeker, which tracks the target and determines the point of impact (Source: U.S. Army).

During this development, TI purchased scanning FPAs from the Sofradir Group (which employed a derivative of the SAGEM MCT diode process) for a main battle tank FLIR they developed for Turkey. This procurement strategy was at least partially responsible for getting Sofradir on a track to commercial success, because the "Turkey FLIR" was effectively the pathfinder second-generation production sensor.

To develop its own staring sensors, Martin Marietta (later to become Lockheed Martin) made a significant investment in quantum well IR photodetectors (QWIPs), which were based on a superlattice of GaAs and aluminum GaAs (AlGaAs). First developed at Bell Telephone Laboratories, the QWIP (Figure 8-4) leveraged existing microwave integrated circuit technology and fabrication facilities. The QWIP was inexpensive but required more cooling than LWIR MCT and exhibited low external¹⁶ quantum efficiency (QE). Had InSb staring FPAs not been developed when they were, QWIPs might have been used by the United States at least as mid-wave detectors. As of 2014, only the Europeans employed QWIP FPAs in a handful of operational, mid-wave military sensors, although QWIP FPAs were used in some LWIR commercial products.

Before the Army's GEN2 FLIR technology made the transition to production, DARPA invested more than \$100 million into LWIR MCT manufacturing technology to avoid the manufacturing issues associated with the original common module effort. Honeywell had adopted the double-layer heterostructure approach, and TI bid a newly developed via hole interconnected diode technology that was manufactured on 6-in. silicon wafers. Because HAC refused to sign on as a

merchant supplier for second-generation FPA technology, it was no longer a competitor. This refusal was the HAC sensor operation's attempt to employ its proprietary FPA technology as a system discriminator.

8.5 THE STANDARD ADVANCED DEWAR ASSEMBLY (SADA) SCANNING MODULE

The Army NVESD saw the potential of maturing second-generation LWIR scanning technology and initiated control of the industry by standardizing critical system components. This standardization led to the SADA modules, which were intended as an upgrade to the existing common module systems and, like the common modules, could be used across the battlefield. The program became known as Horizontal Technology Integration (HTI) where the term "horizontal" meant introduction to existing platforms without waiting for the introduction of new platforms to incorporate the new sensor. A family of TV-compatible SADA scanning modules were defined including 288x2 or 4, 480x4 or 6, and 960x4 or 6 (anticipating high-definition TV) but the latter was dropped, and a noninterlaced 480x4 or 6 emerged as the principal assembly.

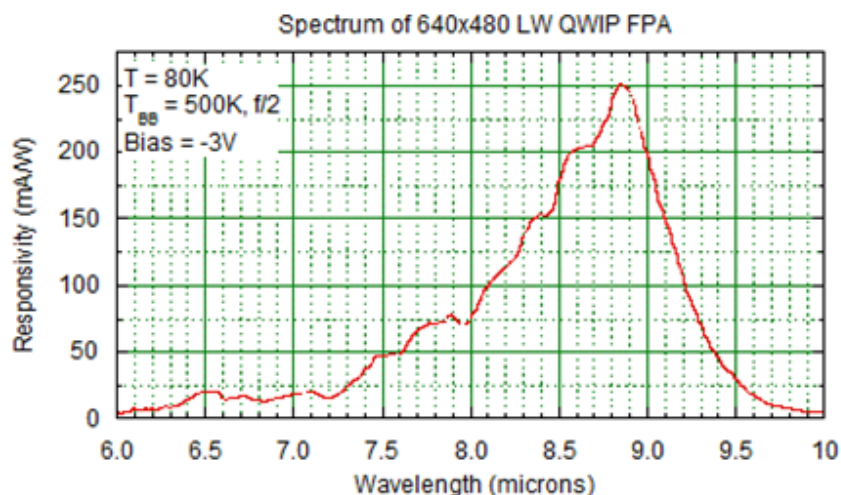
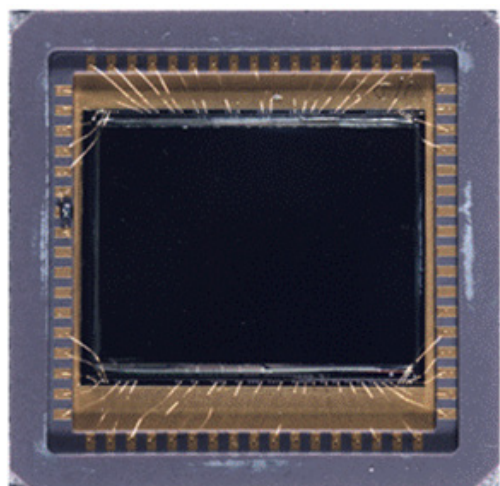

Figure 8-4. 480x640 QWIP FPA (left) and typical "peaked" spectral response curve (right). Perhaps the lowest-cost LWIR technology, the QWIP had low QE (< 10% external QE) and higher dark current (requiring an operating temperature usually less than 70 K) than comparable MCTs (Source: Lockheed Martin).

¹⁶ External quantum efficiency includes the effect of optical losses such as transmission and reflection.

Although GEN2 MCT was based on LPE MCT, DARPA also funded GE, HAC, Rockwell, and TI to develop MBE, which was initially developed at LETI-LIR in France in the late 1970s. This funding was one of the government's first attempts to get competing companies to work closely together during the precompetitive phase of an emerging technology (Figure 8-5). GE, Rockwell, and TI complied with the government's intent and, as a result, several key technical hurdles were overcome. But it would still take many years after this effort before MBE MCT would emerge as a production technology.

TI and HAC SBRC (in spite of the DARPA investment at Honeywell) emerged as the two sources for second-generation scanning FPA technology. Their 480x4 FPAs formed the basis for tank FLIRs and an upgraded fire control FLIR for Army rotary-wing platforms (Figure 8-6). A smaller version developed at TI was employed in the Javelin command launch unit. The GEN2 technology was more expensive than original estimates (some due to manufacturing cost and some to over-specification by the Army) and to encourage competitive cost cutting, the Army paid Sofradir (France) to become a qualified supplier [49]. Costs came down, but by

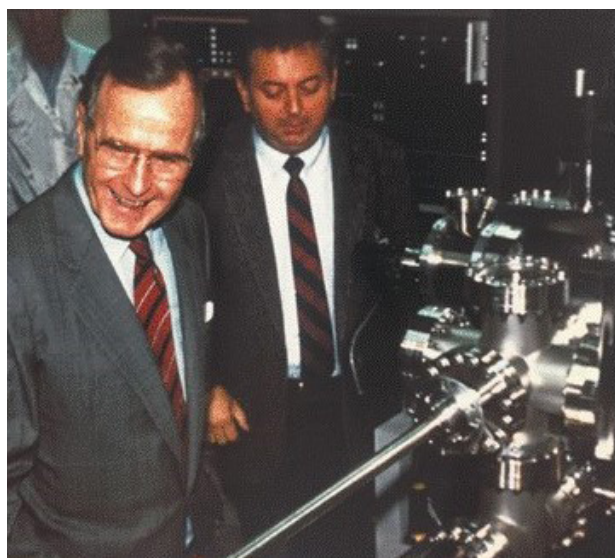

Figure 8-5. President George Bush learning the basics of MBE MCT from Professor Jan Schetzina from North Carolina State University (NCSU). This custom machine was an early U.S. attempt to explore this new technology funded by GE (later by DARPA) (Source: NCSU and BAE Systems).

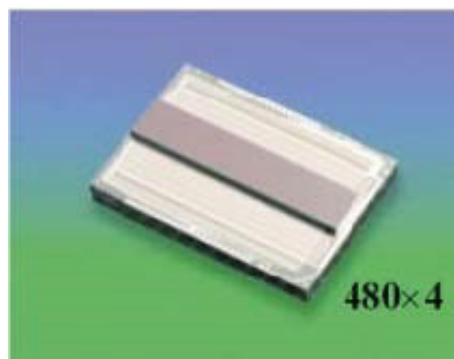

Figure 8-6. The principal GEN2 Common Module IDCA (Integrated Detector Dewar Assembly), (left), contained a 480x4 LWIR MCT FPA, (right), in a sealed Dewar with cryocooler and drive electronics. The additional pixels on target and TDI feature provided a significant range advantage over GEN1 imagers (Source: Laser Focus World [left photo] and Opto-Electronics Review [right photo]) [50].

now there was a French sensor technology with comparable performance and fewer export restrictions. Any U.S. thermal imaging technology advantage of GEN2 was lost before it was fully deployed. However, GEN2's improved recognition range was a significant advance for U.S. forces.

By the second Gulf War, a variety of U.S. platforms had been outfitted with FLIRs based on LWIR photovoltaic FPAs. Many of these FLIRs were used in combat, including the M1A2 Abrams tanks and M2A3 Bradley Armored Personnel Carriers (APCs) equipped with GEN2 480x4 LWIR MCT FPAs (Figure 8-7). In addition, F-16 and F-18 strike fighters were equipped with 480x640 MWIR InSb FPAs, and C-130 Spectre gunships were equipped with 240x4 LWIR MCT FPAs. Javelin missiles



Figure 8-7. Bradley GEN2 FLIR with 480x4 SADA II FPA. GEN2 was a significant improvement over GEN1 night sights and enabled engagement at longer ranges with improved probability of target identification (Source: DRS Technologies, Inc.).

and launchers were equipped with LWIR MCT 64x64 FPAs and LWIR 240x2 FPAs, respectively. The FLIRs on the M1 and M2s performed especially well, enabling U.S. forces to operate under very severe sandstorm conditions and black smoke from burning oil wells. However, few sensors were fielded due to their higher-than-expected manufacturing cost. It is noteworthy that the InSb FPAs in the Air National Guard's F-16 targeting pods had been produced in Israel, which was a strong signal that the U.S. dominance in IR technology was eroding.

The principal InSb imaging sensors included targeting pods for the Navy (Raytheon, formerly HAC) and the Air Force/ Air National Guard (Martin Marietta/Lockheed-Martin and Northrop Grumman). They included missile seekers, such as the Aim 9-X and others, by Raytheon/HAC and the Terminal High-Altitude Area Defense (THAAD) by FLIR Indigo. In addition, Raytheon provided the imaging tracker for the BAE Systems' Advanced Threat Infrared Countermeasures (ATIRCM) directed countermeasure. L-3's Cincinnati Electronics division provided large-format InSb FPAs for prototype surveillance sensors (Air Force and Navy) and the Joint Strike Fighter distributed-aperture sensor (DAS) for Northrop Grumman (Figure 8-8). A disadvantage of MWIR InSb was the requirement to operate at LN2 temperature, the same as for LWIR Common Module. MWIR MCT can achieve equivalent



Figure 8-8. F35 Distributed Aperture Sensor (DAS) employed multiple staring InSb-based FPAs. Larger-format arrays provided enhanced target acquisition range allowing weapons platforms to engage from the relative safety of higher altitudes (Source: U.S. Air Force).

performance at 120 K to 150 K, but as of 2014, the perceived cost differential favored InSb, and most U.S. production MWIR imagers and seekers remained InSb based.

8.6 SUMMARY

By the early 1980s, ROIC technology, including its hybrid mat- ing with photovoltaic detectors, was advancing rapidly. This fertile period began with a focus on MCT as the preferred detector material and, by the mid-1990s, successful 2-D scanning arrays of MCT were being manufactured. However, MCT was still a challenging material to work with, and greater success was being achieved in the design and manufacture of InSb staring arrays. The next chapter describes GEN2 FPA development with focus on the latter material, but it also describes the development of uncooled FPAs that used other materials including an entirely different detection mecha- nism. The result was the availability of several FPA types. This was a good outcome for the IR world since the various ma- terials and detector types all had application domains where their particular advantages were needed.

CHAPTER 9. GEN2 FLIRS WITH INSB AND UNCOOLED FPAS, AND SYSTEM PERFORMANCE MODELING ADVANCES

9.1 INTRODUCTION¹⁷

The availability of indium antimonide (InSb) for detectors enabled FLIR designs that were better optimized for airborne ground-targeting applications. InSb enabled smaller and lighter systems, lower costs, longer ranges in certain atmospheres, and larger format FPAs. Likewise, the emergence of uncooled, room-temperature¹⁸ FPAs had a major impact in opening ground applications such as driver aids and rifle scopes, but these FPAs also were well suited for small drones and unattended sensors. Their development was remarkable given the difficult struggle to accommodate cryocoolers in FLIRs. But uncooled devices were ultimately the product of GEN2 emergence since these devices would not have achieved practical sensitivity without the invention of the focal plane multiplexer, the key enabling technology for all GEN2 FLIRs.

GEN2 systems also required extensive improvement to existing models to make key design tradeoffs unique to GEN2 FLIR characteristics. Those improvements, gained from insights into human visual perception, allowed GEN2 FLIRs to realize their full potential.

The development of InSb detectors was much easier than that of MCT detectors. Section 4.5.2 described the pioneer-

ing work with InSb that led to its development by SBRC for application in the F-14 IRST. SBRC also developed InSb detectors for space-based sensors that, because of security, are still largely kept from public view. Presumably, spaced-based sensor development played a major role in maturing InSb technology. Nevertheless, there were other major contributors as well. Jim Wimmers, a principal founder of CE, which later merged with L-3, lived through the period of InSb advancement and chronicled many of the advancements made by CE and other companies for this history. His inside perspective, provided in this chapter, offers valuable historical insights into the emergence of InSb.

The development of uncooled FPAs is discussed following the Wimmers-based InSb history, and the discussion relies heavily on inputs from Marion Reine who was a close colleague of Paul Kruse, the inventor of microbolometric FPAs. Chapter 4 described Kruse's key contributions to FLIR development made possible by his MCT discoveries. However, his uncooled FPAs were another breakthrough with a vast impact on military uses but it also had civilian night vision applications as well.

Finally, the last section describes the efforts made in FLIR performance modeling and analysis. Many of the performance improvements promised by GEN2 FLIR technology were not realized when they were first invented because of the poor understanding of how human observers process fixed-pattern noise and by the failure of performance models to incorporate noise traceable to the human observer's eyes. These model improvements were needed to fully understand, exploit, and optimize the performance made possible by GEN2 FLIR technology.

¹⁷ This chapter draws from the following sources as well as other references cited in the text. Content from these sources has been heavily edited and merged by the authors.

- Excerpts from Jim Wimmers (AVCO/CE/L-3): "Document Written for SENSIAC by Request" (with photos, edits, and release approval obtained with the assistance of Mark Greiner) [51].
- Excerpts from Marion Reine (Honeywell/BAE/Infrared Detectors) with permission, "Paul W. Kruse (1927–2012), In Memoriam" [52].

¹⁸ Use of the words "uncooled" and "room-temperature" are often used interchangeably but often "uncooled" FPAs were actually cooled with small, low-power thermo-electric (TE) coolers attached to the focal plane to keep them at room temperature.

9.2 INSB FPA DEVELOPMENT [51]

9.2.1 Early InSb Detector Fabrication and Applications

Cincinnati Electronics (CE) had been involved in defense-related IR detector technology since the 1960s. At the time, it was part of the AVCO Corporation and had a systems group that dealt primarily in radar systems. The group's experience in radar sensors probably enabled it to receive a development contract from the U.S. Air Force to investigate the feasibility of using IR detectors as part of a Tail Warning System for the F-111 Fighter/Bomber. The program eventually became known as the Counter Measures Receiver Set and later was given the nomenclature AAR-34. It is believed to be one of the first major systems to use InSb detectors. It consisted of several InSb high aspect ratio detector elements placed end-to-end.

InSb detector fabrication was first developed in the 1960s by Ford-Philco, but the fabrication method was considered crude by almost any standard. An InSb boule was pulled using the Czochralski growth method from a molten mass of indium and antimony, with a small amount of tellurium to make it n-type. As the boule was being pulled from the melt, cadmium was added to the melt to make it p-type, so that the final boule had a hemispherical dome in the middle where the transition from n- to p-type occurred. The boule was cut lengthwise into planks, polished and electrochemically stained to identify the p-n boundary. The plank was cut into bars so that each had a p-n junction near the center, and five bars were mounted side by side to produce a five-element array.

After initially purchasing the devices from Ford-Philco, CE brought the process in house. Then in the late 1960s, a CE research team developed a more reliable, less labor-intensive method of fabricating arrays using closed-ampoule gaseous diffusion and photolithography techniques. The process was developed by a CE research team headed by Dr. Norrn Gri, who later worked at SBRC. Many of the processes developed are still used today in the manufacture of InSb FPAs. In closed-ampoule gaseous diffusion, n-type wafers (cut hori-

zontally from a Czochralski-grown boule, then polished) were sealed in a glass ampoule with a small amount of high-purity cadmium. Elevated temperatures would evaporate the cadmium, creating a partial pressure of cadmium vapor in the sealed ampoule, resulting in a highly compensated p-type layer on top of the n-type substrate. Chemical etch-resistant photo-resist was applied to the surface to create the desired detector shape and size. Similarly, photolithographic techniques were used to apply metal contacts to the individual elements.

Detectors from that late 1960s era did not have a well-defined active area. IR radiation could be absorbed 10–20 μm laterally displaced from the p-n junction itself, and the minority carrier that was created could diffuse to the junction and still create a photocurrent. This design gave the appearance of a wider, lower QE detector and limited how close detectors could be placed in an array without crosstalk issues. The early solution to this problem was to expand the contact pads to cover most of the semiconductor surface. This solution created other problems in that the contact pads could not be continuous for obvious reasons, and the gaps between them still allowed photons to enter the detector material. The area under the metal contact created a depletion zone with very high diffusion length. Consequently, minority carriers that previously would diffuse only 10–20 μm could move 100s of micrometers, creating signal spurs further away than the ones the design was trying to eliminate. Also, the added capacitance of the enlarged contact pad added to the thermal (kT , or Boltzmann's constant \times temperature \times capacitance) noise of the signal chain. Later, another solution was devised that would benefit large-format arrays. A grounded metal layer was constructed that covered the whole of the array, exposing only the top surface of the p-layers, thus creating well-defined, active areas with extremely uniform response. This was known at CE as the buried metallization technique.

Missile Applications. A later version of the original Sidewinder Air-to-Air Missile (AIM9-L) replaced lead salt detectors with InSb in the early 1970s. These were single-element

detectors used in a reticle scan seeker head. The detector was in a small, evacuated Dewar assembly, cooled by a Joule-Thompson cryostat. As of 2012, AIM9-L Sidewinder missiles were still used by the U.S. Navy.

Another large-volume program started in the late 1970s when General Dynamics Missile Division in Pomona (and later Rancho Cucamonga) began the Stinger Missile (FIM-92) program. In this program the detector was mounted on an unevacuated stem and cooled with a J-T cryostat. The seeker head was sealed and back-filled with dry nitrogen, so the detector could be cooled for short periods of time without moisture condensing on the detector surface. The earliest version of this missile seeker used a large-diameter InSb single-element detector and a reticle scan, although later versions would use a smaller-diameter InSb element combined with a UV detector and employed a rosette scanning technique. This program had detector assemblies built by both CE and Raytheon. Over 70,000 Stinger missiles were built. Programs such as Sidewinder and Stinger and the AAR-34 were responsible for expanding the industrial base for InSb detectors in the 1970s and 1980s, allowing more reliable, repeatable fabrication processes, and increasing the starting wafer size from less than 1 in. in diameter to several inches.

9.2.2 Near IR Mapping Spectrometer (NIMS) and Galileo

CE became involved in the IR astronomy community when the Jet Propulsion Laboratory (JPL) awarded CE a contract to build the NIMS Detector Assembly, an instrument that would fly on the *Galileo* spacecraft to Jupiter. Impressed with the stability and high R_0A ¹⁹ of CE's detectors, astronomers at Cal Tech began using them for Earth-based instruments as well. At the time, InSb detectors were used for radiometry, measuring the irradiance of stars at various wavelengths in the 1–5 μm range. With no need for small size or portability, astronomers could cool the detectors using liquid helium to 4 K. Prior to this time, InSb detectors exhibited an unusual

phenomenon, whereby when operated at 4 K for prolonged periods, the detectors' resistance-area (R_0A) product would gradually degrade, which would lead to higher output noise.

Keith Matthews, an astronomer at Cal Tech, developed a procedure of exposing the detector to 1.25- μm radiation before initiating measurements; this process was referred to as "J-lashing." He observed that this process increased the R_0A product of the detector by more than an order of magnitude. He speculated that the surface states at the termination of the p-n junction were causing a low impedance path around the main active area of the diode. Exposing the detectors to J-band radiation apparently emptied these surface states and improved the detector impedance. He also noted that over time the R_0A product would gradually decrease as the surface states filled up again.

However, CE InSb detectors did not exhibit this phenomenon of gradually lower impedance during operation. Moreover, they did not respond to J-flashing and had extremely high impedance without it and not only at zero bias. The detectors functioned well even in reverse bias, with low leakage currents for several hundred millivolts. It was concluded that because the grounded metal layer was being applied over the edge of the mesa where the p-n junction terminated, the nature of the surface states changed enough that they were either unoccupied or nonexistent. Further studies showed that biasing the metal layer rather than grounding it improved the reverse bias characteristics, although this would prove to be difficult to implement in large, multi-element arrays.

CE's contact at JPL, Gary Bailey, was interested to know how uniform the characteristics of linear InSb arrays would be as opposed to just single elements. He then commissioned a program to build an array of 0.008 x 0.008-in. elements as long as the existing wafer technology would allow, which

¹⁹ R-naught x A [or detector resistance (R_0) x area product (A)] is a performance metric wherein a high R_0A is desirable in photovoltaic detectors to provide high impedance.

was only about an inch. The resulting arrays demonstrated that 64-element arrays could be fabricated that had responsivity uniformity of a few percent and uniformly low leakage current in reverse biases of as much as 500 mV.

About the same time, Bailey became aware of a company named Spiricon that offered a product with 32 and 64-element multiplexed linear arrays of silicon photodiodes. The device was sold as a method to profile laser spots. Unlike more complex CCDs that were common at the time, these devices were "switched capacitor arrays" (capacitive discharge arrays). They relied on a single MOSFET switch to connect a single silicon photodiode (fabricated on the same substrate) to a common readout line, and a clocking circuit allowed each sequential MOSFET to connect its associated photodiode, or detector, to the common output. For each sequential connection, the detector was biased to a specific negative voltage, and then disconnected. For the period of time until the detector would be reconnected to the common output, incoming radiation generated a photocurrent that reduced the negative bias of the silicon photodiode. When the detector was again connected to the common output, the new voltage would be read and the voltage difference from the original voltage was almost linear with the incoming radiation. It is interesting to note that a whole

new nomenclature (reset voltage, integration time, leakage current, etc.) quickly developed that is commonly used today. Of course, nearly all modern commercial cameras for visible light use this switched capacitor technology in their FPAs.

Bailey quickly made the connection that this linear array readout device could be used with InSb linear arrays. A few test devices were made by wire bonding the InSb detector to an exposed contact near the silicon diode. The silicon diodes were small in comparison and had negligible leakage current in comparison to the InSb diode but, so long as the assembly was filtered to pass only IR radiation, the only photocurrent generated was from the InSb detector. This multiplexer that Spiricon sold was actually manufactured by another company, Reticon. CE and JPL approached Reticon and had a multiplexer made, eliminating the silicon photodiode and adding a bond pad to facilitate connection to the InSb array. The resulting hybrid structure demonstrated the efficacy of the switched-capacitor readout technique for uniform, high-impedance InSb detectors. Until this time, readout circuits were almost always discrete, transimpedance amplifiers. Each amplifier had individual junction gate field-effect transistors and feedback resistors for each detector channel, as in the 17-channel sensor package built for the NIMS instrument (Figure 9-1) on Galileo. CE sold several of these multiplexed

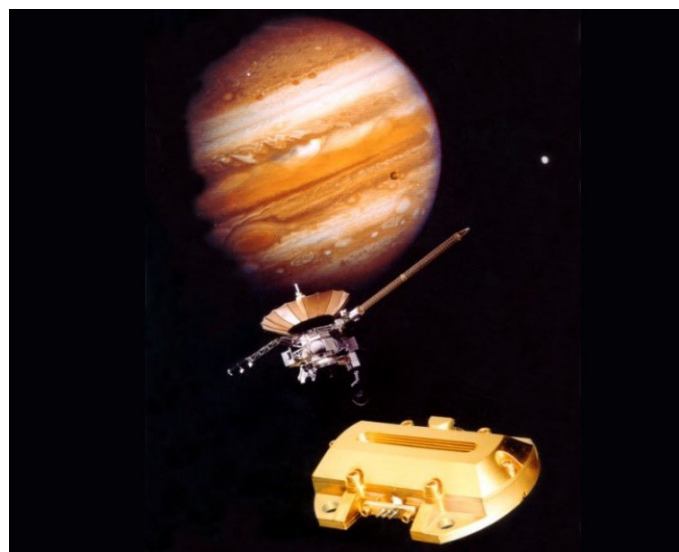
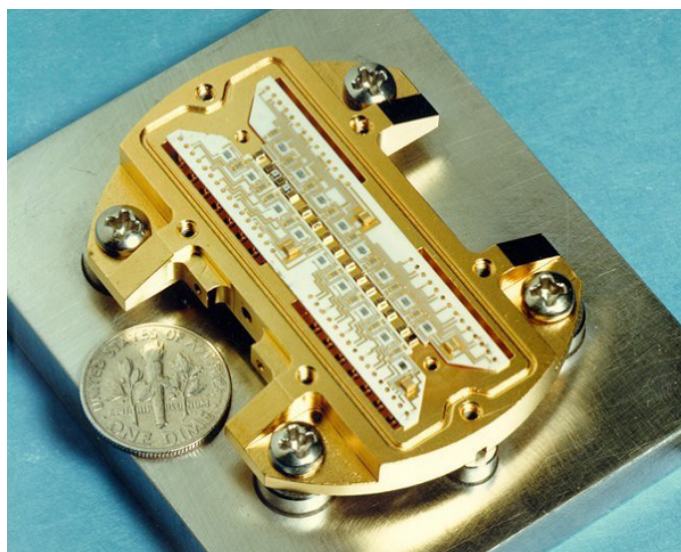

Figure 9-1. Galileo satellite with IR detector array for the NIMS (Source: L-3).

linear array devices as a standard product primarily for astronomy applications, and used the nomenclature integrated multiplexed hybrid (IMH) array or IMH-32, IMH 64, and IMH-128. JPL also contracted CE to build a 512-element switched capacitor array as the sensor package for the visible/IR mapping spectrometer (VIMS) instrument (Figure 9-2) that flew on the Cassini spacecraft that went into orbit around Saturn.

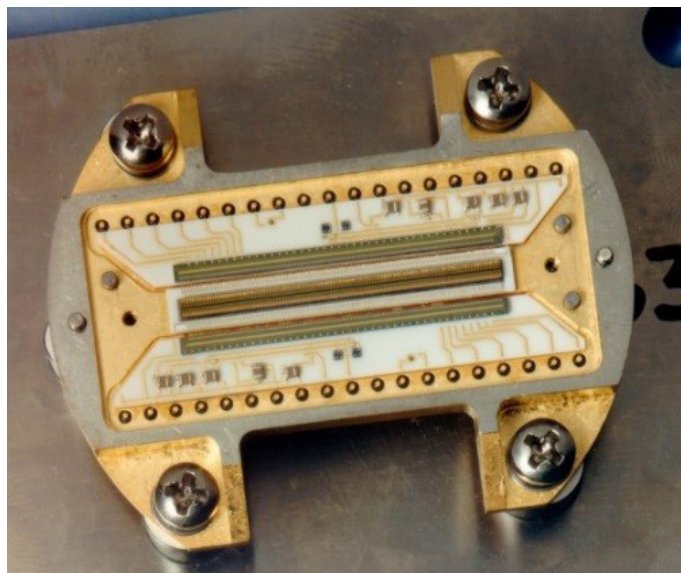

Figure 9-2. Multiplexed InSb detector array for the VIMS (Source: L-3).

The commercial viability of these linear array devices was short-lived, as the age of 2-D staring arrays was now beginning. Nevertheless, the demonstration of a direct input, switched capacitor technique would prove critical to CE's later successes.

By the late 1980s, a few of the larger companies (Rockwell, HAC SBRC, TI) began producing the first 2-D arrays. Several key technologies were required to build an array, and only this small group had the internal sources for these technologies. The capital equipment requirements were also prohibitive to small companies or small groups within larger companies. The most important element was a source for 2-D silicon multiplexers. Each of these three companies had internal silicon integrated circuit (IC) foundries (and in-house IC designers) that could develop and build the multiplexer.

Of course, each company had a detector capability as well, primarily MCT, since most military FLIRs were made of long wave MCT. Bump bonders were commercially available since they were being used in flip chip ICs, but they cost several hundred thousand dollars each. Similarly, arrays, once bump bonded, had to be thinned to a thickness on the order of 10 μm , so photons would not create carriers too far away from the p-n junction area, lest they recombine before being swept across the junction. The only available thinning technique at the time was diamond turning, and diamond turning systems cost between \$500,000 and \$1 million. The combined cost of those two systems alone was three to four times more than the annual capital budget of CE's detector group (CE's main line of business at the time was still military communications). CE had made inquiries to several of the major defense companies, but for obvious reasons they were unwilling to sell multiplexers to companies they viewed as competitors. CE did not see a pathway to participating in this new technology.

For several years, these companies dominated the 2-D IR industry. For the most part, the devices being developed were mid-wave and long-wave MCT arrays, since the funding source was primarily the U.S. Army. The conventional wisdom at the time was that mid-wave MCT could eventually be made to operate at high enough temperatures so that a cryocooler would not be required. SBRC made an InSb array, but its intended market for that device was IR astronomy and was operated at liquid helium temperatures (4 K). Then several events led to CE's entrance into the market:

1. The understanding of the importance of spatial noise.
2. The growth of a "cottage industry" of self-employed IC multiplexer designers.
3. The establishment of stand-alone silicon foundries.
4. The development of a novel front side illuminated array that did not require diamond turning as a thinning technique.
5. The availability of miniature, low-power cryocoolers.

9.2.3 Spatial Noise

Most of the technical conferences at the time were dominated by the major companies (Rockwell, HAC SBRC, TI), and the focus was primarily on improved sensitivity, measured by detectivity, or D-star (D^*). This was the common method of determining the quality of single-element and linear arrays. For at least a year, the performance of 2-D FPAs was shown at these conferences as a histogram of the individual D^* of each element. The quality of an array was represented by measurements such as the average D^* and the minimum D^* of 99% of all the elements. A few static images might be shown, but it would be a few years before real-time video processing would make video possible. For unlike silicon imaging arrays whose signal variation from element to element was less than a percent, the responsivity and offset values of each individual element in an IR array varied significantly and required each element to be corrected with a unique gain and unique offset value. There were no processors that could do this in real-time.

A group from Hanscom AFB, led by Dr. Freeman Shepard, had been working on an alternative technology—platinum silicide (PtSi). Their approach was to fabricate a PtSi Schottky barrier diode directly on the surface of the silicon multiplexer. The resulting structure produced an array with high operability and excellent uniformity, but with only ~1% quantum efficiency. It also eliminated the need for bump bonding and hybrid structures. So, while the MCT companies were reporting D^* values of $10E10$ and $10E11$, Shepard's group was showing only $10E8$ and $10E9$. Many competing groups did not consider the work competitive, and in some cases, it was derided. It was not until real-time imagery of higher D^* arrays was available and began to be reported that the real value of Shepard's approach was understood.

Wimmers [51] remembered the stunned silence in the room when the first PtSi video images were shown at an IRIS conference. Because of the purity of Si available for Si-based Schottky diodes, responsivity and dark current were exceptionally uniform and remained uniform over FPA operating

temperature variations as well. Clearly objects could be detected with the low-sensitivity PtSi array that could not be seen in MCT arrays with sensitivities sometimes two orders of magnitude greater. Normally the variation in signal of a single detector due to its electrical noise could be expressed as how much of a temperature difference in the scene would be required to produce the same signal amplitude. That metric became the standard noise equivalent temperature difference (NETD). Now it quickly became understood that a new method of determining the quality of an imaging array would be necessary. The "spatial noise" or variation in gain or offset between each element of an array was as important to consider as the electrical noise of each individual element. The new metric that would be used would be the "spatial noise equivalent temperature difference" or spatial NETD. Consequently, NETD due to individual detector/readout circuit noise was added in quadrature to the nonuniformity-based spatial NETD to result in a total NETD of the FPA. It was then easy to understand why the PtSi FPA imagery looked better than its MCT-based counterparts of the time. While the early MCT FPAs had very low detector-based NETD, that NETD was overwhelmed by the high spatial NETD due to nonlinear gain and gain drift with operating temperature. On the other hand, PtSi arrays had very low spatial NETD, and were limited instead by their detector NETD, which was lower than the spatial NETD of the MCT FPAs.

After array nonuniformity effects started to be understood, nonuniformity "correction" techniques began to be applied. One of the first techniques used to correct arrays was to place a uniform, low-signal source in front of the array, record the signal of each element, and repeat using a uniform, high-signal source. (In some cases, it was as rudimentary as using white and black pieces of cardboard.) The measured values for slope and offset were the equivalent of gain and brightness, and two corresponding constants for each element could be stored in memory and used to correct the output as each element was read out of the array. This process was referred to as a "two-point correction," as illustrated in Figure 9-3. While it eliminated the vast majority of the nonuniformities in the images, it had several limitations. Most impor-

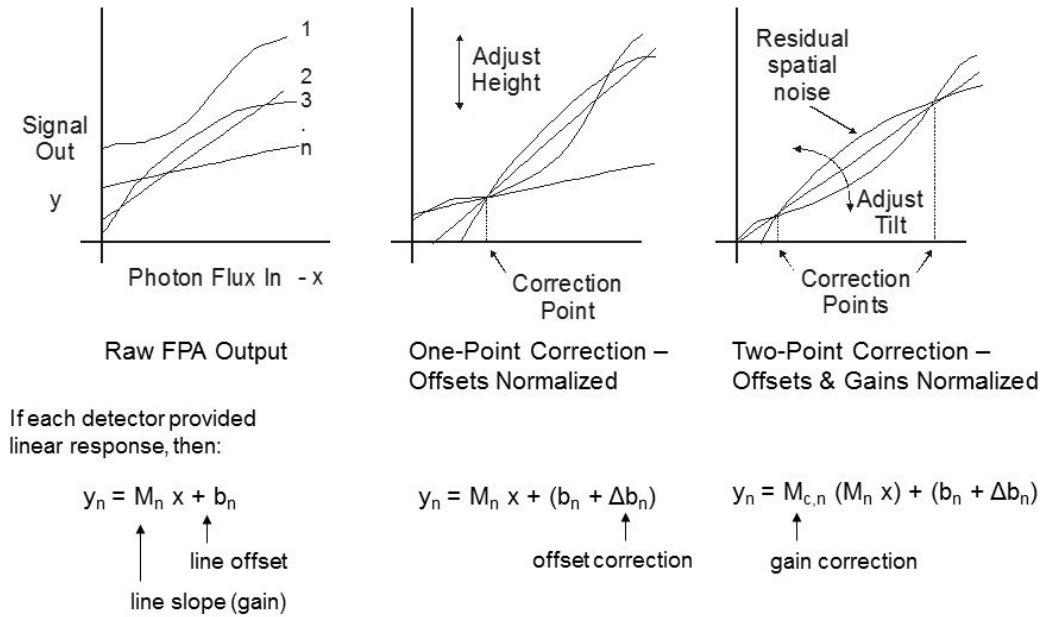

Figure 9-3. NUC Process (Source: Georgia Tech ITA course notes [1] as adapted from Metschuleit et al., Amber Engineering).

tantly, the actual gain (or slope) for most ternary and binary devices was not linear, so while an image might be corrected for a given scene, a slight increase or decrease in the temperature of the scene would immediately create very noticeable nonuniformities in the image. Also, slight variations in the operating temperature of the array would change the characteristics of the individual diodes and lead to the same result. The first video images of MCT arrays exhibited many of these limitations, with grainy images being the result, even with high D^* values. It was not until later, when calibration sources were mounted inside the FLIR and used for in-field nonuniformity correction (NUC) implementation and updates, did systems finally begin to control and limit fixed-pattern noise to levels reliably below detector temporal noise.

PtSi FPAs had another significant advantage at the time. Because they were monolithic devices, they were not affected by problems caused by the differential coefficient of expansion of silicon and the material from which the detector was made, whether MCT or InSb. As a result, PtSi FPAs were being made that were as large as 512x512, when the largest hybrid arrays were still 128x128.

However, the PtSi FPA technology was short lived. Only one major program used a PtSi FPA, the B-52 FLIR. Mitsubishi developed an imager using PtSi, which was an early commercial success. But the approximately 1% quantum efficiency in the mid-IR range was the limiting factor for PtSi-based FPAs, and they were overtaken in performance by other detector technologies once the spatial NETD issues were understood and solved. Nevertheless, the PtSi FPA performance showed the IR community that they needed to focus more attention on a heretofore never measured parameter, namely spatial NETD. And because InSb detectors were binary compounds and more well behaved than their ternary equivalent in the mid-IR (MCT), these merits would pave the way for InSb FPAs.

9.2.4 Multiplexer Designers and Si IC Foundries

As stated in Section 9.2.2, only a few defense companies had the internal resources to design and fabricate their own readout devices. But that situation began to change as companies such as Orbit Semiconductor, Inc. began to process designs for outside customers. At the same time, the Pentium microprocessor was making the custom, IC-design workstation obsolete. A single, high-end PC was capable of generating a circuit and mask set design for very complex

ICs. As a result, multiplexer designers that had been employed by larger, vertically integrated companies were no longer constrained by the significant capital investment of a design workstation. And, with the rise of semiconductor foundries, there was a demand for multiplexer designers' services outside of their present employer. Several multiplexer designers struck out on their own, formed companies, and a cottage industry for IC design developed. Several of the early companies included Walmsley Microelectronics, Augustine Engineering, Black Forest Engineering, and Valley Oak Semiconductor.

As CE was developing the design described in Section 9.2.5, they also contacted Charles Walmsley of Walmsley Microelectronics in Scotland and commissioned him to design and build a multiplexer based on the switched capacitor circuit that CE used in its linear multiplexed arrays (the design was based on the processing design rules for a foundry in a Marconi facility in England, but the identical design would later be fabricated by Orbit Engineering in the United States). The design and fabrication of the original batch run of these 64x64-cell multiplexers would cost very little and were completed in a few months from the time of the initial contract award.

9.2.5 CE's Novel 2-D FPA Design

Although multiplexed readout structures were becoming more available, CE's detector group still lacked the capital equipment necessary to fabricate the 2-D InSb detector array. The standard process then (still in wide use as of 2012) was to fabricate a 2-D array of photosensitive junctions, then indium bump bond them to the corresponding multiplexer device. The remaining space between the two materials (silicon multiplexer and InSb or MCT array) that was not filled with the indium bumps was backfilled with a rigid epoxy material to add mechanical rigidity and support. Then the InSb array was thinned to approximately 15 μm using a diamond turning machine. CE's detector group did not own and could not afford a diamond turning system. However, CE at the time had extensive experience with Logitech lapping and

polishing systems through their involvement with the Stinger program that used a UV detector that was thinned to a few hundred micrometers. CE personnel had tried unsuccessfully to use this equipment to thin InSb to the required thickness; uniformity across a single device could not be achieved. (The polishing process had only approximately 10- μm uniformity, and that was the required thickness of the end structure.)

Then one of CE's process engineers (Al Timlin) conceived of an approach, circa 1993, to resolve the polishing problem. He suggested epoxying a whole InSb wafer of 2-D arrays to a sapphire substrate, with the detector side facing the sapphire. Since both the epoxy and sapphire were transparent to most of the MWIR, the other side could be thinned to 40 μm using the lapping/polishing equipment. Then, the remaining material between the active elements could be selectively chemically etched, until all that remained were individual InSb p-n junctions each held to the host substrate by epoxy. (This meant that the InSb array would not have the thermal expansion/contraction properties of InSb at all, since the diodes were now mechanically isolated, but rather would have the properties of the host substrate, a fact that would be exploited in later years for very large arrays.) Another grid of "grounding lines" was applied using standard photolithographic techniques to electrically reconnect all the diodes. Figure 9-4 illustrates the overall configuration. So now instead of a p-on-common-n structure, the new device was n-on-common-p. The original attempt to implement this structure was performed on a 64x64 array of elements on 100- μm centers. It worked the first time. This first device was fabricated by Chuck Martin, a CE process technician. Mr. Martin would continue to develop 2-D array processes for CE over the next 25 years.

These first devices were built on sapphire substrates, not only because they were transparent in the MWIR, but also because it was necessary to be able to see the front side of the array for alignment during processing and bump bonding. This worked well enough for the original devices, but after 100 cryo cooling cycles, the arrays would begin to delaminate in the corners. This of course was due to the difference in

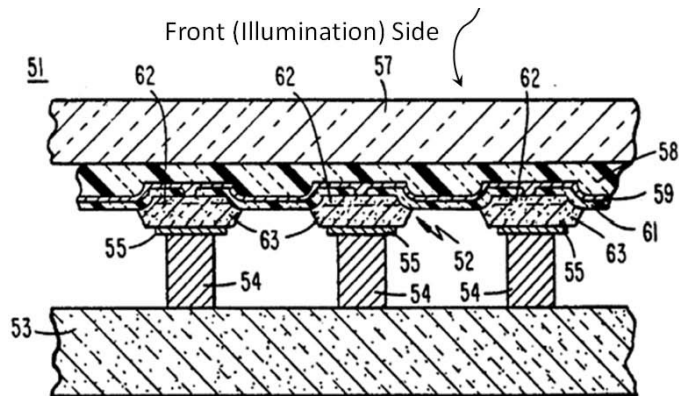

Back Side

KEY

- | | |
|-------------------------------|---------------------------|
| 51 - transparent backing | 58 - epoxy glue |
| 52 - detector diode array | 59 - metal grid connector |
| 53 - multiplexer IC substrate | 61 - oxide layer |
| 54 - Indium columns | 62 - P-type doped regions |
| 55 - metal contact pads | 63 - N-type doped regions |
| 57 - sapphire insulator plate | |

Figure 9-4. Front side illuminated and reticulated IR detector array from L-3 CE patent 5,227,656, 13 July 1993 (Source: L-3).

coefficients of expansion between sapphire and silicon. While it was a lifetime-limiting feature for the 64x64 arrays, it caused delamination immediately in the next-generation 160x120 element devices. It was clear to CE engineers that if the "Frontside Illuminated Array" process was going to work, the host substrate that the InSb was built on would have to have a much closer CTE match to silicon. The only real alternative was to use silicon as the host substrates. After finding a work-around for the alignment issues, CE began building all of its 2 D arrays with silicon substrates. Because there was now an exact match between the two materials on both sides of the indium bumps, CE's design was uniquely suited to extremely large arrays and would provide a strategic advantage in this market niche.

The original target market for the 64x64 array was IR astronomy, and the product was introduced as the IMH-64 and sold as an array only. It was not well received, as CE was too late to the market (SBRC had already developed and sold a 64x64 array to the astronomy community). Fortunately, around the same time, CE had developed a compact set of electronics with which to conduct its own imaging tests (IR astronomers

were notorious for developing their own custom drive and readout circuitry to minimize noise in low-background applications, so no market was envisioned for drive and readout electronics). At the same time, Diversified Optics (DIOP) was beginning to sell a low-cost, 50-mm IR lens (approximately \$2,000). CE found that it could mount the array in a relatively small LN2 test Dewar, attach the DIOP lens and the electronics it had designed for its own test and evaluation, and sell the resulting package as a low-cost IR camera. The first product was the IRC-64 and sold for less than \$17,000. CE sold enough of these cameras to demonstrate that there was a commercial market for 2-D IR cameras. The experience provided enough interest to convince CE to continue development of larger arrays that were introduced as the IRC-160 and the IRC-256. Note that the commercial market was important in the early days of InSb IR cameras, as the DoD had not yet shown an interest in this product.

9.3 DEVELOPMENT OF GEN2 UNCOOLED DETECTORS

9.3.1 Invention of the Microbolometer [52]

The development of MCT was not the only revolutionary development pioneered by Paul Kruse during his distinguished career at Honeywell Corporate Research Center. The second of Kruse's two revolutionary developments was the silicon-based microbolometer array. In the early 1980s, Kruse and his Honeywell colleagues pioneered the integration of silicon microbridge bolometer detectors with CMOS ICs to develop the first uncooled IR FPAs. The Honeywell Solid State Electronics Division, Honeywell's in-house silicon foundry, had developed silicon microbridge devices originally for gas flow sensors. In the early 1980s, Kruse recognized that the high thermal isolation of the microbridge architecture was exactly what was needed for a high-performance, uncooled bolometer IR detector. The early development of the uncooled microbridge IR detector is described in a book chapter by Kruse's Honeywell colleague and collaborator, Andrew Wood. The following quote from Wood's chapter, "Monolithic Silicon Microbolometer Arrays," describes the role that Kruse played in initiating the uncooled microbridge array technology in Honeywell [53]:

Kruse (1982) showed by calculation that Si micro-machined microbolometers could have a performance approaching the ideal performance for a room temperature IR sensor, and proposed their construction as two-dimensional staring focal planes for low-cost uncooled IR imaging.

Kruse and his Honeywell colleagues Wood, Bob Higashi, Bob Johnson, C. J. Han, and others pioneered the integration of silicon microbridge bolometer detectors with CMOS ICs to develop the first uncooled IR FPAs. Uncooled microbolometer FPA technology advanced rapidly, and eventually microbolometer FPAs entered high-volume production as the premier technology for low-cost thermal imaging sensors for a wide variety of both commercial and military applications.

9.3.2 Other Significant Historical Developments in Uncooled Detectors

For uncooled detectors, the key enabler for GEN2 devices was again the multiplexer, but there was also one very important breakthrough in detector design: the ability to isolate the detector from its surroundings. To work at their highest efficiency, the detectors needed to be thermally isolated from their immediate surroundings. The Honeywell microbridge approach discussed in Section 9.3.1, accomplished that isolation by micromachining a gap between the detection layer

and the underlying multiplexer circuit. That gap established the desired conduction barrier. Figure 9-5 illustrates the geometry including the legs that both support the detection layer and provide circuit access.

However, in addition to the Honeywell bolometer approach, a ferroelectric approach was also developed for uncooled thermal detector FPA design. It too exploited GEN2 multiplexer and mechanical isolation technology. So at least two uncooled thermal detector types were used: ferroelectric and bolometric. Ferroelectric detection used barium strontium titanate, which was developed in the 1970s at TI. It worked on the principle that a temperature change caused realignment of unbalanced charges in the material's structure and subsequently caused current flow. Bolometric detection, on the other hand, measured a resistance change caused by the temperature change. Bolometric designs ultimately provided better performance. In bolometer detectors (now called microbolometers) a layer of material that exhibits high resistance change with temperature (i.e., high temperature coefficient of resistance) was used for the detector layer. Temperature change was then sensed by pulsing a current through that layer to measure the resistance change. Most microbolometers used vanadium oxide, but many also used amorphous silicon as the temperature-sensitive layer.

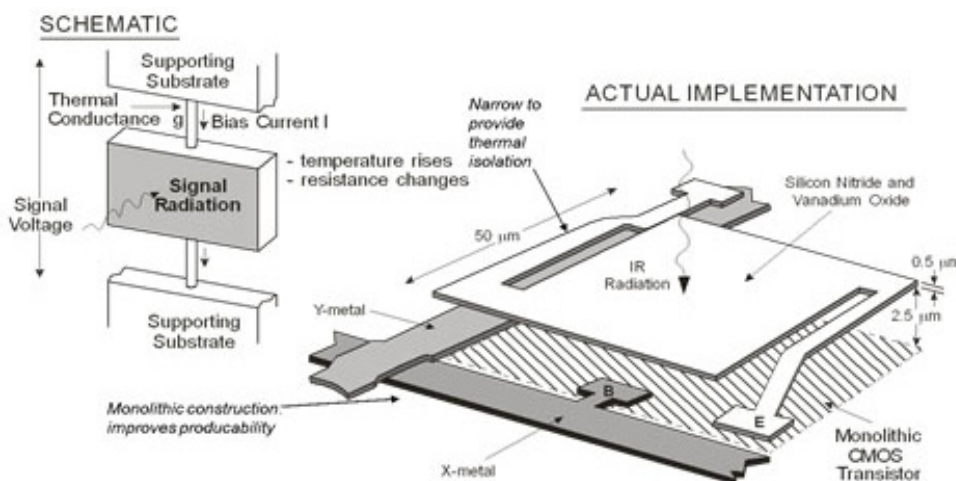

Figure 9-5. Microbolometer FPA showing microbridge design (Source: Georgia Tech ITA course notes [1] as adapted from R. A. Wood [53]).

Uncooled detector FPAs did not perform as well as cooled FPAs, but they offered lower cost in smaller, lighter packages and still provided performance comparable, or better than, GEN1 FLIRs with cooled detectors. Those features opened up a wide range of applications that would not have been as viable had cooled devices been the only option. Such applications ranged from man-portable rifle sights to night driver aids to missile seekers. Automobile manufacturers found them compelling enough that General Motors, circa 2000, offered them as a \$5,000 extra cost option on Cadillacs. Others followed, and commercial applications soon opened up ranging from security cameras to night vision devices for law enforcement.

9.4 ADVANCEMENTS IN FLIR MODELING AND ANALYSIS [1]

9.4.1 FLIR Modeling Developments Overview

The development of analytical tools to predict the performance of FLIRs played a significant role in both optimizing FLIR system parameters (focal length, aperture size, video bandwidth, display design, etc.) and focusing attention on key component technologies where improvement would provide the most system performance. This section addresses recent advances such as in optimizing GEN2 designs by understanding the important effects of fixed-pattern noise (FPN, also called spatial noise, as previously discussed in Section 9.2.3) display size/viewing distance, observer filtering of FPN, and the effects of observer eye noise. Without this understanding, as captured in FLIR performance prediction models, GEN2 FLIRs could not have reached their full potential. Finally, new FLIR designs and optimal utilization of past FLIR generations still in-service have benefitted from ongoing studies of the significant impact that background clutter plays in observer target acquisition. Those studies, with their findings and conclusions, are also addressed in this section.

9.4.2 System and Observer Noise Modeling for GEN2 FLIRs

As mentioned in previous chapters, Fred Rosell, Bob Sendall, and others pioneered the understanding of human visual

system psychophysical factors involved in viewing fast framing video information display. Their work was captured in an NVL computer modeling code by James Ratches [41] and his colleagues at NVL [25]. It was used extensively for optimizing GEN1 FLIRs including the writing of design manuals [46].

However, early models were not adequate for predicting the performance of GEN2 FLIRs. One problem was that GEN1 models were largely optimized for one-dimensional, horizontal-scanning, linear arrays, and not for 2-D, staring, FPA-equipped imagers. Moreover, the GEN2 FLIRs were so much more sensitive that their temporal noise levels were now comparable to those found in the human eye. Therefore, human eye noise levels had to be understood and included in the noise models. In addition, temporal noise was at first smaller than spatial noise until techniques were developed to suppress the latter and until criteria were developed to determine how much suppression was required.

Spatial noise was noticeable in scanned GEN1 FLIRs as well, but it was only in the vertical direction since each horizontal scan line was generated by a different detector. Even then detector/amplifier/LED response differences were largely compensated for by factory-set, field-maintainable, potentiometers that reduced channel imbalances. But residual imbalances still existed in the vertically arrayed raster lines due to drift over time, temperature changes, etc. More importantly, the pixel dwell time of the scanning detectors was much shorter than in GEN2 staring detectors so the former had less exposure to the background flux and thus correspondingly lower FPN. While the GEN1 vertical FPN was smaller, it was also less noticeable due to both the much higher apparent temporal noise of the GEN1 FLIR and the scan line raster structure itself. Finally, models only addressed GEN1 performance in the horizontal scanning direction so vertical FPN was not even accounted for.

Surprisingly, when early GEN2 FLIR performance was first measured in the field, it was found to be substantially less than what was predicted by existing models. The main reason was the poor understanding of the effect of FPN

on overall observer noise perception [54] and subsequent underestimation of its impact. That impact included the debilitating effect of amplifier boost or aperture correction, i.e., the process of preferentially increasing amplifier gain at higher frequencies to mitigate resolution roll-off due to such effects as optical diffraction and detector size. GEN1 FLIRs used high levels of boost but only applied it in the horizontal scan direction since that was all they could effectively do with horizontally scanned discrete detectors and analog electronics. So, there was no amplification of the FPN. Now, since GEN2 FPAs had nonuniform detector response in the horizontal direction as well, high-frequency gain also preferentially increased the FPN which, in turn, imposed a limit on how much gain was useful.

Human factors research conducted at the Army NVESD (formerly NVL) by John D'Agostino and Curtis Webb [54] provided the scientific basis for model improvements with assistance from Richard Vollmerhausen [private communication, circa 2006], Barbara O'Kane, Mel Friedman, and others. Ronald Driggers et al. [55] and many others at NVESD, ONR, and U.S. Army Training and Doctrine Command [25] captured and extended these later findings in greatly improved computer codes that allowed GEN2 FLIR designs to be further optimized and thus come closer to realizing their potential.

9.4.3 Background Clutter Modeling

A key gap in FLIR performance prediction analysis and modeling was recognized in the early 1980s when the Air Force initiated a program called the Tactical Decision Aid (TDA). While the program started in that period, it initiated a long series of research programs that were greatly expanded over the ensuing decades and were still ongoing at the time of this book writing. The goal of the TDA program was to provide mission planners with a prediction tool that would allow them to prebrief pilots on critical aspects of their targeting process. With the proliferation of airborne FLIR targeting systems, it soon became apparent that pilots and/or their weapons system operators (WSOs) needed help because their survival depended on it. The targeting process often

required pilots to fly at high altitudes so they had a clear line-of-sight to their targets, i.e., one not obscured by tree lines and hills or other masking obstacles. But then enemy radar and optical air defense systems could more easily spot and shoot them down. It was critical that pilots be able to quickly locate their targets to minimize their exposure to enemy defenses. Hence, it was important to not only know where to look, but to know what characteristics of the target to look for. For instance, was it positive or negative contrast? Would it have a strong, positive contrast signature, such as an armored air defense unit that had been exposed to solar heating all day? In the latter case, its heavy armor would retain heat long after a lighter foliage background cooled off at night. Or would it have a strong negative contrast, after the sun came up in the morning? In this case, it would take much longer for heavy armor to heat up than would the much lighter background foliage. Such information was even more critical for the mission planner because it would allow them, with the benefit of TDA software, to predict the range at which the pilot could detect the target so they could "popup" at that range and thus minimize the time they would spend exposed to enemy fire. Many phenomena had to be included in the TDA software such as weather predictions and their effect on signature generation and propagation. Of course, FLIR performance characteristics would be critical.

The Avionics Laboratory at Wright-Patterson AFB asked co-author David Schmieder if he and his employer, Georgia Tech Research Institute, could provide FLIR modeling help based on his industry experience modeling and designing FLIRs while employed at Martin Marietta, now Lockheed Martin. Schmieder accepted the assignment but realized that then-current performance prediction models were missing critical FLIR performance criteria necessary for the TDA. That missing criteria included the resolution required by a FLIR to allow the operator to perform target detection in varying degrees of background clutter. The venerable Johnson bar target equivalency resolution criteria for target detection did not control for background clutter, nor was there even a metric that could characterize and quantify clutter.

The Air Force Avionics Lab accepted a proposal from Schmieder and his colleagues to perform a human factors study using Georgia Tech students after target detection training to repeat Johnson's bar target equivalency measurements for target detection. The goal was to measure detection probability as a function of resolution for targets embedded in varying, but controlled, amounts of background clutter. To conduct the study, they had to first determine a clutter metric. Kowalczyk and Rotman described the outcome in Chapter 28 of Biberman's 2000 book, *Electro-Optical Imaging: System Performance and Modeling* [25] this way:

In the early 1980s a method based on the "average" scene radiance (or equivalent) standard deviation was proposed by Schmieder and his coworkers at Georgia Institute of Technology [56]. This method partitioned the image into square blocks (approximately twice the size of the target), calculated the variance of the pixel intensities within each block, then root mean square averaged the result over all the blocks. The authors called this the "rms clutter variance." Since that time others have referred to this as the "Schmieder Statistical Variance" (or SV).

...A combined measure called the signal to clutter ratio (SCR) was defined as the maximum (or, if negative, absolute) difference between the target and background mean radiance divided by the rms clutter radiance.

...The approach ... was a major advance since for the first time, it was possible to calculate a target transfer probability Function (TTPF) curve for a specific level of clutter in an image.

While the study results were immediately incorporated into Air Force TDA software, the study authors regarded their definition of both signal and clutter as merely an embryonic start on a long journey to refine the definition of both clutter

and signal as progress in image understanding science progressed. Moreover, the initial study only applied to natural backgrounds. A later study by Cathcart, Doll, and Schmieder extended the results to urban backgrounds [57]. Many studies subsequently followed as other researchers took up the quest. The result was ongoing continuous evolution in criteria for the resolution required for FLIRs when used for target detection as described in a 2015 Sandia report [58]. The Navy and Army soon also adopted TDAs as mission planning tools for their air crew mission planning needs.

9.5 SUMMARY

This chapter described the evolution and development of GEN2 FLIR technology up to approximately the mid-2000s to 2010. It focused on InSb as the material that resulted in the emergence of affordable 2-D staring arrays and their role in the development of large FPA formats. While MCT was the material of choice for ground-to-ground combat for various reasons including its better penetration through battlefield smoke and dust and its greater sensitivity in cold climates, InSb was better suited for airborne applications. This suitability for airborne applications was due to its shorter wavelength operating band which allowed for smaller apertures, with attendant reduction in SWaP-C, without sacrificing range. Moreover, aircraft could fly above the battlefield fray and did not need the better smoke and dust penetration as much as ground units. In addition, the emergence of FLIRs with uncooled FPAs opened a whole new realm of applications that were now practical because of their much lower cost and size. By the mid-2000s to 2010, FLIR technology had evolved to where it provided a robust solution to the historical demands of the battlefield, but this period was dynamic and was by no means nearing its full potential.

The optimization of GEN2 FLIRs demanded better modeling and analysis capabilities for their promise to be realized. Fixed pattern noise severely limited their performance until it was recognized and suppressed. Greater GEN2 sensitivity resulted in so much lower display noise that it rivaled the noise

inherent in observers. Thus, models had to now take observer eye noise into account to correctly predict "system-observer" performance.

Finally, the practical military need to plan missions for optimum air crew survivability led to factoring in the complexities of background clutter into the design of FLIR targeting systems. The variety and complexity of backgrounds led to new definitions of both clutter and target signature. These background considerations brought new insights into the psychophysics of the human vision system that is ongoing and likely to continue yielding new insights into FLIR design optimization.

CHAPTER 10. SUMMARY, CURRENT TRENDS, AND LESSONS FOR THE FUTURE

10.1 INTRODUCTION²⁰

IR technology has undergone a remarkable transformation over the last 50-plus years. As of 2016, it has played a critical role in U.S. defense capability by providing the day and night vision that gives U.S. forces a major advantage. Of course, the real value of any history is the lessons it holds for the path forward. To speculate on that path, this chapter first provides a summary of FLIR military history and then discusses current trends and apparent direction. The goal is to discuss FLIR technology as of the date of this book and to set a baseline for speculating on the path forward. Final conclusions offer thoughts on the path forward and on the lessons for guiding military FLIR technology on that path.

10.2 SUMMARY

The history of military FLIRs discussed in this book has focused on the key enabling technologies that contributed to their development. However, many more supporting technologies were required for FLIR development than were discussed in this book. Examples are advances in optical lens and coating materials, digital microelectronic integrated circuits, cryocoolers, and Dewars. Also important were phenomenology studies such as atmospheric absorption and scattering as well as scene and target signature studies that helped analysts predict FLIR performance. Those technologies and studies, with their impact on FLIR development, should not be minimized but their history is either left to others to write or have already been written and published in various books and journals.

With the above caveats in mind and for the purpose of a broad overview summary, the following chronology lists significant events leading to or directly addressing the history of U.S. FLIR technology development up to the early 2000s:

- 1800: Astronomer Sir William Herschel discovered the IR region of the electromagnetic spectrum.
- Mid-1930s: PbS photoconductive detectors were invented and used in early search systems.
- 1950–1960: Single-element detectors produced line scan images of scenes that enabled finding and tracking enemy dismount forces.
- 1954: Otto Schade introduced the concept of Modulation Transfer Function (MTF) as a metric for quantifying the resolution of image-forming systems.
- 1958: John Johnson introduced the concept of "bar target equivalency" as a metric for quantifying the resolution needed for varying levels of target acquisition.
- Late 1950s: William Lawson discovered MCT IR detector properties.
- Early 1960s: Paul Kruse and his colleagues at Honeywell discovered methods to fabricate MCT detectors.
- 1968: Robert Sendall introduced the aggregate FLIR metric Minimum Resolvable Temperature (MRT) that made it possible to optimize FLIR performance.
- Early 1970s: Common module building blocks for FLIRs were developed, thus enabling affordable, mass-produced, GEN1 FLIRs that were made from discrete-element, photoconductive MCT detector technology.
- 1970s–1980s: Analog multiplexers were developed that led to the fabrication of large-detector-count GEN2 arrays; MCT and InSb detector technology efforts focused on photovoltaic design and producibility.
- Mid-1980s: Paul Kruse and his colleagues at Honeywell invented microbolometer FPA technology and developed uncooled IR FPAs.

²⁰ The discussion of current trends and future projections includes excerpts from Teague and Schmieder's paper in the fall 2015 issue of the *DSIAC Journal* [59].

- 1980s–1990s: Significant progress was made on large, 2-D InSb FPAs and uncooled device technologies. MCT technology efforts focused on GEN2 scanning devices.
- 1990s–2000s: Initial technology development began on MCT dual-band devices; MCT, InSb, and uncooled 2-D staring devices were used widely in applications including targeting and surveillance systems, missile seekers, driver aids, and weapon sights.

Substantial government funds were expended to insert these now-proven IR devices into military payloads and missile seekers and later into commercial products. As a result of the success of military research and development programs, new applications were identified, and products were moved into production. Thermal imaging technology provided the ability to see and target opposing forces at night and across smoke- and dust-covered battlegrounds. These capabilities backed the Army's claim that "we own the night."

10.3 CURRENT TRENDS AND FUTURE PROJECTIONS

Urban Warfare Requirements. As a key military technology, FLIR development has always been driven by the evolution of the threat. A major concern has been threats that come from adversaries that employ unconventional tactics (i.e., terrorists and insurgents), but that does not mean adversaries that employ conventional tactics can be ignored. Traditionally, the U.S. military has chosen to avoid close combat in cities in preference to using its superiority in long range standoff weapons to defeat conventional forces. Yet, evolving world demographics coupled with political turmoil have drawn conflict into urban areas. That fact is especially true in those parts of the world that are becoming increasingly unstable due to the combination of terrorism and hordes of refugees attempting to escape violence and avoid starvation. These urban areas provide a hiding place for radical extremists where it is hard to deploy conventional weapons and tactics. This situation has led to warfare that is increasingly fought in urban environments. New kinds of high-performance IR imaging systems already play a critical role in this warfare, and the more advanced systems in development will likely play an even larger role.

Success in urban warfare largely depends upon the ability to accomplish the following (adapted from Carson [60]):

- Find and track enemy dismounted forces, even when their appearance is brief or mixed with the civilian population.
- Locate their centers of strength (e.g., leadership, weapons caches, fortified positions, communication nodes, etc.), even when camouflaged or hidden in buildings.
- Attack both light and heavy targets with precision, with only seconds of latency and little risk to civilian populations and infrastructure.
- Protect U.S. forces from individual and crew-served weapons, mines, and booby traps.
- Employ robots in the form of drones such as unmanned air vehicles and unmanned ground vehicles as well as unattended sensors.
- Protect our own forces and homeland infrastructure from these same drones, which in miniature, can fly in undetected while carrying miniature IR sensors that allow for precise day/night delivery of explosives.

Persistent Surveillance Systems. To meet these requirements imaging systems must provide persistent surveillance from platforms located almost directly overhead and from small, stationary, and maneuverable platforms on the ground. Also needed are imaging systems that perform targeting and fire control through haze, smoke, and dust. Overhead systems must have the resolution to recognize differences between civilian and military dismounts, and some of them must perform change detection based on shape and spectral features. Others must quickly detect and locate enemy weapons by their gun flash and missile-launch signatures.

Near-ground systems must have the resolution and sensitivity to identify individuals, at relatively short ranges, from their facial and clothing features and from what they are carrying. They must also be able to do it through windows and under all weather and lighting conditions. Some must be able to see through obscurations, such as foliage and camouflage netting. In most cases, collected imagery will be

transmitted to humans who are under pressure to examine it and make quick, accurate decisions. As such, it is important that imagery be highly intuitive and easily interpretable. This persistent, up-close, and personal sensing strategy requires many and varied platform types. Cost is an important factor due to ongoing budget constraints. Not only the sensors, but the platforms that carry them, must be affordable; but some must also be man portable. Accordingly, many sensors must be small and light.

Solutions to some of the surveillance requirements are being addressed with current persistent surveillance systems such as ARGUS-IS and ARGUS-IR (Figure 10-1). ARGUS-IS has an enormous array of 368 optically butted FPAs using four co-boresighted cameras. They combine for a total of 1.8 gigapixels that can provide separate images of 640x480 pixels to as many as 65 operators. The operators can then independently track separate ground objects or persons of interest within the ground footprint of the combined sensors with a ground resolution of approximately 4 in. at a 15-kilo-foot (kft) platform altitude. ARGUS-IS operates in the visible/NIR band and requires daylight, but the DoD is developing the more advanced ARGUS-IR to field comparable capability at night.

Microbolometers. Other IR surveillance technologies involve unattended sensors that can be covertly deployed in either urban or rugged country terrain. Figure 10-2 shows an example of how tiny uncooled LWIR microbolometers can be. When triggered in the field, for instance, by a change detection software, they can snap a picture of passing insurgents and feed that to the battlefield network for targeting. They have low SWaP-C, are expendable, and can run for a long time on batteries and solar power.

While the emergence of small surveillance drones has driven the need for lower-weight and lower volume payloads, often performance cannot be sacrificed, and microbolometers cannot always meet these payload requirements. For these requirements, there is an ongoing drive for small-pitch FPAs that operate at higher temperatures, often above 150 K. Overall

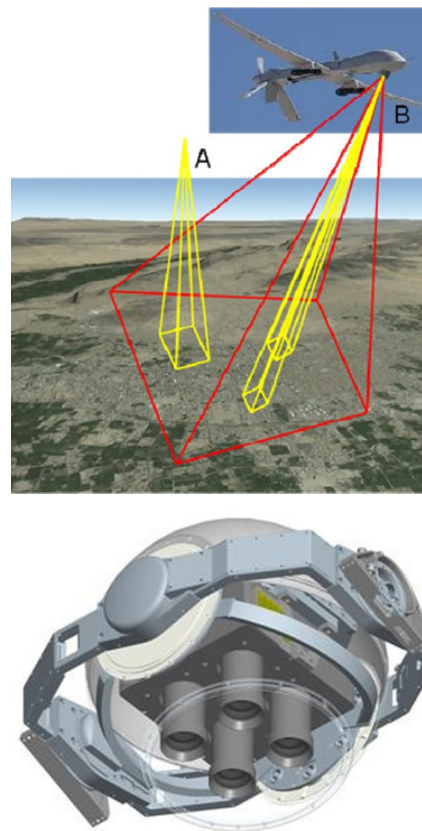

Figure 10-1. ARGUS-IS has 368 5-megapixel FPAs that provide 1.8 gigapixels on the ground with a resolution of 4 in. at 15 kft in the visible/near-IR band. One planned MWIR version (ARGUS-IR) would provide over 100 cooled FPAs each with 18 megapixels [61–63].



Figure 10-2. The Lepton microbolometer is an example of how small IR imaging sensors can be made. They can be used for covert, unattended operation in either remote or urban locations and connected to the battlefield network (Source: FLIR Inc.).

sensor size, for equal performance, scales with detector pitch as long as the aperture size is maintained. Smaller pixels allow for a reduction in the Dewar and cooler size and weight and for reduction of the optical focal length. Accordingly, package size and, to a large degree, package weight can be reduced in proportion to detector pitch. The current trend appears to be moving to 10–8- μm pitch for MWIR sensors, but some LWIR FPAs are being made with the pitch as small as 5 μm .

Emerging systems are being designed to counter the proliferation of IR imagers in the hands of the insurgents as well. Readily available commercial microbolometers are potentially a major threat. Although these imagers typically have lower resolution and sensitivity than what advanced technology can provide, adversaries can effectively use these cheap, low-resolution sensors and still fire at U.S. forces at long ranges. To counter this threat, the Army's desire for increased standoff range resulted in development of a third generation (GEN3) of staring sensors with both MWIR and LWIR capability. The shorter MWIR wavelength offers nearly twice the range of the LWIR band in good weather, but the LWIR band excels in battlefield smoke and dust and provides greater range in cold climates.

GEN3 Technology. Currently, GEN3 technology is expensive. The high cost is associated with both low detector yield and complex optics. Detector cost is being addressed on two fronts: alternate substrates and new detector materials. A GEN3 detector is made by placing MWIR detector material behind LWIR material so the two bands occupy the same space in the focal plane. Currently, only two materials offer this potential: MCT and superlattices. MCT is most easily made on CdZnTe substrates because the lattices match well, thus providing higher yield. However, lower-cost GaAs and Si substrates are being explored with considerable success. The other front exploits the potential for a radically different material type called a superlattice. Superlattices exploit nanotechnology to engineer materials from the III-V columns of the periodic table to make alloys such as indium arsenide antimonide (InAsSb) and indium arsenide (InAs). In principle,

they have many favorable characteristics such as strength, stability, and low cost. However, they have wide band gaps. To detect low-energy MWIR and LWIR photons, they have to be fabricated in thin, alternating layers to form quantum wells. Superlattices have the additional benefit of being compatible with another breakthrough in detector design called negative-barrier-negative junctions. The latter have an advantage over traditional positive-negative junctions (such as are commonly used in commercial solar cells) in that they can better suppress the dark current that arises from latent heat in the material. This characteristic, in turn, offers the potential for higher-temperature operation. Current success is so far largely in the MWIR region, but success is expected in the LWIR region as well. It remains to be seen if it will be a better solution than MCT.

The dual-band GEN3 approach is actually a subset of multispectral and hyperspectral imaging. The latter offers additional modalities and is often best exploited with sensor fusion techniques. But it faces challenges and is still in development. Multispectral images must be displayed or processed simultaneously in each band to extract target information. In addition, for operator viewing, they must be combined into a single, composite image using a color vision fusion approach. The best way to accomplish that fusion and display it to an operator is still being investigated. However, results have shown impressive reductions in false-alarm rate and probability of missed detections when, for instance, searching for targets hidden in deep tree canopies and/or under camouflaged nets.

Passive/Active Fused Sensors. Airborne and Naval platforms have taken an entirely different approach to gaining extended-range target identification. Their approach can, in principle, triple the range of existing targeting FLIRs. They are adopting passive/active hybrid systems consisting of passive IR imaging for target detection in combination with active lidar (light detection and ranging, analogous to radar as "radio detection and ranging") for high-resolution identification. Figure 10-3 shows an example of this imagery provided by BAE. The principle is that lidars can image with much

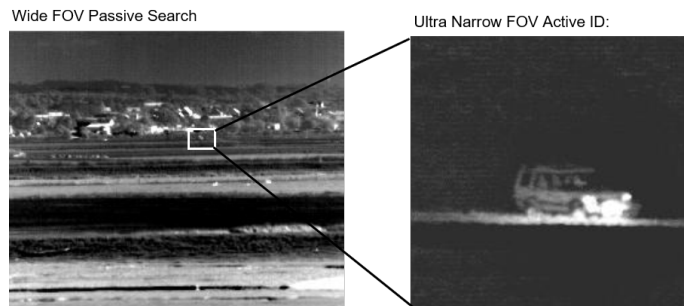

Figure 10-3. In a passive/active targeting system, the FLIR is used for passive target detection and the lidar is used for active identification [64] (Source: BAE, UK).

shorter wavelengths, near $1.54\text{--}1.57\ \mu\text{m}$, to greatly reduce the diffraction blur diameter of the optics with a corresponding increase in range. Moreover, this choice of wavelengths is eye safe. These systems have just recently been fielded on aircraft and ships (Figure 10-4).



Figure 10-4. The U.S. Air Force LITENING G4 pod uses active imaging for extended-range target identification (Source: USAF).

However, perhaps the biggest breakthrough is about to be achieved: It has long been the *Holy Grail* of imaging systems to provide their own ability to not only see, but to understand what they are seeing. For instance, drones are merely flying platforms that are useless without their data link to a remote operator who pilots it, views its imagery, and selects targets. In future combat, data link survival is not assured. In the near future, lidars are expected to help solve the challenge of image understanding in autonomous systems by advancing to 3-D shape-profiling of targets. Current 2-D “automatic target recognition” technology has yet to accomplish that [65] despite millions of dollars and over three decades of research. But if targets can be profiled in 3-D and then compared to a stored library of 3-D wire-frame target models, the goal might finally be achieved. It would be highly unlikely to mistake an object for a false target when it is accurately compared in 3-D and when it is presented with an appropriate FLIR thermal signature as well. Ultimately, hybrid 3-D lidar/FLIRs, together with advancements in artificial intelligence (AI) (discussed in the next subsection), will likely open up the battlefield to a portentous and controversial transformation: the replacement of human warriors on the battlefield with autonomous robot warriors.

AI. AI advancements are starting to come at a pace in the software world that is complementary to and synergistic with advancements in microelectronics. This pace in AI advancements is due to the fact that AI requires enormous amounts of computational power and data storage. A major AI area that is particularly promising for battlefield application is “deep learning” with artificial neural networks (ANNs). ANNs mimic biological networks by providing layers of cross-connected parallel connections. Recent advances in graphical processing units (GPUs) have resulted in parallel structures that have been found to be adaptable as artificial ANNs. When ANN processors are exposed to large amounts of data, they can “learn” to detect patterns that exceed that of human analysts. For military application, AI processors can be exposed to a wide range of scenes with target-like images and can then classify objects by feature association without human intervention. When programmed to detect particular

targets, they can eventually learn to recognize subtle differences that reduce their false-alarm rate to acceptable levels, given learning databases that are sufficiently large. This process has the advantage of being adaptive, i.e., amenable to continuous learning, as target features change with continuing exposure to the evolving battlefield. Such capability, when coupled with both passive and active IR sensors, promises to reduce false target identification rates to acceptable levels. This advancement has the potential to allow armed, autonomous battlefield robots to function alongside friendly forces and civilians without fear of unacceptable collateral damage.

Digital ROICs (DROICs). Finally, there is at least one more transformative, emerging IR technology, DROICs, and they are already being tested [66]. Recall that all GEN2 and GEN3 FLIRs as well as many lidars are enabled by analog ROICs. These devices provide the critical capability required to multiplex millions of parallel detector signals into a serial output signal placed onto a single wire. A major problem they have is the lack of charge storage capacity. IR scenes produce enormous "background" flux, and the desired signal is only a very small percentage of that flux. Existing ROICs cannot store the resulting charge in their pixels and must instead shorten their integration time to throw that charge away. Of course, the signal then gets thrown out too at the expense of sensitivity.

However, DROICs are changing all that because they "count" the photoelectrons as they are being generated before they throw them away. This breakthrough capability is the result of Moore's Law in microelectronics. It is projected that an entire Intel 8086 microprocessor will fit within a single, 30 μm^2 pixel by 2018 when 7- μm feature sizes are expected to become available. In addition, both sensitivity and signal processing are expected to improve. With so much process-

ing power embedded in each IR pixel, it will be possible to implement such space- and power-consuming off-chip tasks as image stabilization, change detection, passive ranging from optical flow²¹ calculations, super resolution,²² and time delay and integration. Lidars will be able to perform range measurements within each pixel to high accuracy. That capability will enable them to measure the shape of even very small objects, which would improve their ability to identify hand-held threats such as handguns. It is apparent that these capabilities are on the verge of yielding still more transformative changes in IR technology.

10.4 CONCLUSION

IR technology has produced sensors that have become an essential component of U.S. defense systems. It is hard to imagine how the United States would defend itself without the benefit of IR surveillance and targeting systems. However, like all technologies, it is diffusing throughout the world. Clearly the ability to sustain the rate of technical advancement in military FLIR technology is critically important. That rate should be sustainable if the U.S. retains the policies that have enabled these advances. They include the obvious need for adequate DoD funding, but funds are always limited and must be wisely leveraged. In the past, that leverage has been obtained through a close working relationship among government laboratories, industry, and academia.

Particularly important have been the roles of IRIS and its later replacement, MSS, in sponsoring regular meetings. Those meetings promote technical exchanges at a level that helps all participants but does not undermine the benefits of healthy competition. Leverage has also been successfully applied through large, collaborative programs such as the DoD-funded Vital Infrared Sensor Technology Acceleration (VISTA) program, which seeks to develop a baseline of

²¹ Optical flow refers to the capability to compute range based on the phenomenon that objects closer to an imaging sensor move outward from the image center faster than do more distant objects.

²² Super resolution refers to the capability to improve image resolution by computationally deconvolving sources of optical resolution loss such as lens diffraction and detector pixel size.

shared technical knowledge and fabrication infrastructure. Thus, each participating company does not have to make a separate, redundant investment in those critical underpinning capabilities. Yet those companies can add value by the way they manage the products and innovate beyond that framework.

So far, advances in IR technology have been driven by advances in materials, in microelectronics, and in understanding human visual perception. However, also important, have been the intangible benefits of the close working relationships among government laboratories, industry, and academia. Microelectronics feature sizes have been shrinking exponentially by Moore's Law. But even if this pace slows, advancement can be expected to be rapid going forward given the synergy between microelectronics and software such as AI. Moreover, microelectronics has room to advance in ways that do not necessarily depend on ever-smaller feature sizes. Examples are structural improvements in chip design such as those in GPUs and in 3-D chip configurations down to the transistor level. While such advances are inexorable, it can be argued that building upon the lessons of the past will lower the cost, help sustain, and may even speed up the rapid pace of transformative changes in military FLIR technology that brought it to where it is today.

REFERENCES

- Schmieder, D. E. "Infrared Technology and Applications." Course Notes, Georgia Institute of Technology, 2015.
- Schmieder, D. E., and G. Walker. *The Infrared & Electro-Optical Systems Handbook*. Vol. 7, Chapter 2, 1993.
- Rogalski, A. "Infrared Detectors: An Overview." *Infrared Physics & Technology*, vol. 43, pp. 187–210, 2002.
- Herschel, W. "Experiments on the Refrangibility of the Invisible Rays of the Sun." *Philos. Trans. Roy. Soc. London*, vol. 90, pg. 284, 1800.
- Wikipedia, "Thermographic Camera." https://en.wikipedia.org/wiki/Thermographic_camera, accessed 16 June 2016.
- Barr, E., and E. Scott. "Historical Survey of the Early Development of the Infrared Spectral Region." *American Journal of Physics*, vol. 28, pp. 42–54, 1960.
- Arnquist, W. N. "Survey of Early Infrared Developments." *Proceedings of the IRE*, September 1959.
- Hudson, R. D. *Infrared System Engineering*. John Wiley & Sons, Inc., 1969.
- Smith, W. "Effect of Light on Selenium During the Passage of an Electric Current." *Nature*, vol. 7, pg. 303, 1873.
- Bose, J. C. "Detector for Electrical Disturbances." U.S. Patent No. 755,840 A, filed 30 September 1901, issued 29 March 1904.
- Case, T. W. "Infrared Telegraphy and Telephony." *Journal of the Optical Society of America*, vol. 6, pp. 39–406, 1922.
- Rogalski, A. "History of Infrared Detectors." *Opto-Electronics Review*, vol. 20, no. 3, 2012.
- Sturdevant, R. W. "From the Pied Piper Infrared Reconnaissance Subsystem to the Missile Defense Alarm System: Space-Based Early Warning and Development, 1955–1970." American Institute of Aeronautics and Astronautics (AIAA) Space 2010 Conference, Anaheim, CA, 2010.
- Lovell, D. J. "Some Early Lead Salt Detector Developments." Air Force Office of Scientific Research (AFOSR)-68-0264, University of Michigan, 1968.
- Johnson, T. H. "Lead Salt Detectors and Arrays PbS and PbSe." *Proceedings of the International Society for Optical Engineering (SPIE)*, vol. 0443, 9 December 1983.
- Lovell, D. J. "The Development of Lead Salt Detectors." *American Journal of Physics*, vol. 37, pg. 467, 1969.
- Williams, R. "The Last Panther in Pomerania." http://www.missing-lynx.com/articles/dio/rwpanth/rwpanth_solutions.htm, accessed 14 July 2017.
- Johnston, S. F. *A History of Light and Colour Measurement: Science in the Shadows*. IOP Publishing Ltd, 2001.
- Sendall, R. "Documents Written for SENSIAC by Request." Hughes Aircraft Company (HAC), Raytheon, 2014.
- Jost, S. "Documents Written for SENSIAC by Request." General Electric (GE), Sanders, Loral, Lockheed Martin Corporation (LMCO), BAE, 2013.
- Taylor, K. "Documents Written for SENSIAC by Request." Texas Instruments (TI), DRS Technologies, Inc., 2014.
- Hudson, R. *IR Systems Engineering*. Wiley, 1969.
- Communications-Electronics Research, Development, and Engineering Center (CERDEC). "History of Army Night Vision." https://www.cerdec.army.mil/inside_cerdec/nvesd/history/, accessed 19 August 2015.
- Wolfe, W. L. (editor). *Handbook of Military IR Technology*. Naval Research Laboratory (NRL), 1965.
- Biberman, L. M. (editor). *Electro-Optical Imaging: System Performance and Modeling*. SPIE Press, ONTAR Corp., 2000.
- Wolfe, W. L., and G. J. Zissis (editors). *The IR Handbook*. NRL, Environmental Research Institute of Michigan (ERIM), Infrared Information Analysis Center (IRIA), 1978.
- Accetta, J. S., and D. L. Shumaker (editors). *The IR & Electro-Optical Systems Handbook*. ERIM/SPIE, 1993.
- Kruse, P. W., L. D. McGlauchlin, and R. B. McQuistan. *Elements of IR Technology*. Wiley, 1962.
- Ponomarenko, V. P., and A. M. Filachev. *Infrared Techniques and Electro-Optics in Russia: A History 1946–2006*. SPIE Press, 2007.
- Lawson, W. D., S. Nielson, E. H. Putley, and A. S. Young. "Preparation and Properties of HgTe and Mixed Crystals of HgTe-CdTe." *J. Phys. Chem. Solids*, vol. 9, pp. 325–329, 1959.
- Kruse, P. W., M. D. Blue, J. H. Garfunkel, and W. D. Saur. "Long Wavelength Photoeffects in Mercury Cadmium Telluride." *IR Physics*, vol. 2, pp. 53–60, 1962.
- Elliott, T. "Recollections of MCT Work in the UK at Malvern and Southampton." *Proceedings of SPIE*, vol. 7298, 2009.
- Talley, R. "A History of Santa Barbara Research Center." Santa Barbara Research Center (SBRC)/Raytheon Vision Systems, July 1995.
- Hunt, G. R., J. W. Salisbury, and W. E. Alexander. "Thermal Enhancement Techniques: Application to Remote Sensing of Thermal Targets." *Res. Appl. Conf. Proceedings*, Office of Aerospace Research, Washington, DC, pp. 113–120, March 1967.
- Harris, D. E., and C. L. Woodbridge. *National Electronics Conference*. Vol. 18, 1962.
- TI. www.ti.com/corp/docs/company/history/timeline, accessed 21 April 2016.
- Johnson, J. *Image Intensifier Symposium*. Fort Belvoir, VA, October 1958.
- Schade, O. H. "A New System of Measuring and Specifying Image Definition." Symposium on Optical Image Evaluation, NBS Circular, 1954.
- Rosell, F. A. "Limiting Resolution of Low-Light-Level Imaging Sensors." *J. Opt. Soc. Am.*, vol. 59, no. 5, pp. 539–547.

40. Sendall, R. L., and F. A. Rosell. "E/O Sensor Performance Analysis and Synthesis (TV/IR Comparison Study)." Air Force Systems Command, 4950th Test Wing PMMA, Wright-Patterson Air Force Base (AFB), OH, November 1972.
41. Ratches, J. A., W. R. Lawson, L. P. Obert, R. J. Bergemann, T. W. Cassidy, and J. M. Swenson. "NVL Static Performance Model for Thermal Viewing Systems." U.S. Army Electronics Command (ECOM)-7043, April 1975.
42. Lloyd, J. M. *Thermal Imaging Systems*. Plenum Press, 1975.
43. TI. www.ti.com/corp/docs/company/history/timeline, accessed 30 August 2015.
44. Coltman, J. W. and A. E. Anderson, "Noise Limitations of Resolving Power in Electronic Imaging." *Proc. IRE* 48, pp. 858–865, 1960.
45. Hanson, C. "Documentation Written for SENSIAC by Request." U.S. Army Night Vision Laboratory (NVL), TI, DRS, 2014.
46. Martin Marietta. *FLIR Common Module Design Manual*. OR-14118-REV-1, Orlando, FL, March 1978, DTIC Rept. # AD A118043.
47. Elliott, C. T. "UK patent application no. 51498." filed 1974, publication no. GB 1488258, published 1977.
48. Amelio, G. F. "Charge Coupled Devices." *Scientific American*, February 1974.
49. Nichols, C., D. Grogan, and R. Schmidt. "The Role of Foreign Comparative Testing Programs In Army Modernization." *Acquisition Review Quarterly*, Fall 2001.
50. Norton, P. "HgCdTe Infrared Detectors," *Opto-Electronics Review*, vol. 10, No. 3, pp. 159–174, 2002.
51. Wimmers, J. "Document Written for SENSIAC by Request." AVCO, Cincinnati Electronics (CE), L-3, 2012.
52. Reine, M. "Paul W. Kruse (1927–2012), In Memoriam." *Proceedings of SPIE*, vol. 8704, 2013.
53. Wood, R. A. "Monolithic Silicon Microbolometer Arrays." In *Uncooled IR Imaging Arrays and Systems*, vol. 47, pp. 45–122, edited by P. W. Kruse and D. D. Skatrud, New York: Academic Press, 1997.
54. D'Agostino, J., and C. Webb. "3-D Analysis Framework and Measurement Methodology for Imaging System Noise." *Proceedings of SPIE*, vol. 1488, 1991.
55. Driggers, R. G., E. L. Jacobs, R. H. Vollmerhausen, B. O'Kane, M. Self, S. Moyer, J. G. Hixon, G. Page, K. Krapels, D. Dixon, R. Kistner, and J. Mazz. "Current IR Target Acquisition Approach for Military Sensor Design and Wargaming." *Proceedings of SPIE*, vol. 6207, 2006.
56. Schmieder, D., and M. Weathersby. "Detection Performance in Clutter with Variable Resolution." *IEEE Trans. on Aerospace & Electronic Systems*, vol. AES-19, no. 4, July 1983.
57. Cathcart, M. J., T. J. Doll, and D. E. Schmieder. "Target Detection in Urban Clutter." *IEEE Trans. on Systems, Man, and Cybernetics*, Vol. 19, No. 5, September 1989.
58. Sjaardema, T. A. C. S. Smith, and G. C. Birch. "The History and Evolution of the Johnson Criteria." Sandia Report SAND2015-6368, 2015.
59. Teague, J. R., and D. E. Schmieder. "History, Trends, & Future of IR Technology." *DSIAC Journal*, vol. 2, no. 4, Fall 2015.
60. Carson, K. R., and C. E. Myers. "Global Technology Assessment of High-Performance Imaging Infra-Red Focal Plane Arrays." Unpublished draft, Institute for Defense Analysis, October 2004.
61. Maenner, P. F. "Emerging Standards Suite for Wide-Area ISR." *Proceedings of SPIE*, vol. 8386, May 2012.
62. Defense Advanced Research Projects Agency (DARPA). "Autonomous Real-Time Ground Ubiquitous Surveillance – Infrared (ARGUS-IR) System." DARPA-BAA-10-02, 2010.
63. Maxtech International. "Infrared Imaging News." July 2010.
64. Baker, I., S. Duncan, and J. Copley. "A Low Noise, Laser-Gated Imaging System for Long Range Target Identification." *Proceedings of SPIE*, vol. 5406, pp. 133–144, 2004.
65. Ratches, J. A. "Review of Current Aided/Automatic Target Acquisition Technology for Military Target Acquisition Tasks." *Optical Engineering*, vol. 50, no. 7, July 2011.
66. Schultz, K. I., M. W. Kelly, J. J. Baker, M. H. Blackwell, M. G. Brown, C. B. Colonero, C. L. David, and D. B. Tyrrell. "Digital-Pixel Focal Plane Array Technology." *Lincoln Laboratory Journal*, vol. 20, no. 2, 2014.

APPENDIX A.

Interview with Paul W. Kruse on the Early History of Mercury Cadmium Telluride (HgCdTe) Conducted on October 22, 1980 [1]

Marion B. Reine

Consultant on Infrared Detectors

Cambridge, Massachusetts 02138

July 2, 2014

I interviewed Dr. Paul W. Kruse (1927–2012) of the Honeywell Corporate Research Center, Bloomington Minnesota on his recollections of the early history of the development of mercury cadmium telluride (HgCdTe). The two-hour interview was conducted in my office at the Honeywell EO Division in Lexington, Massachusetts on October 22, 1980. The two cassette tapes were in my desk drawer for the next 33 years, until last spring when I wrote and presented a memorial paper [2] on Paul Kruse's career for the 2013 International Society for Optical Engineering (SPIE) meeting in Baltimore. At that time, I had the audio tapes transcribed into text, and recently I edited the text to reduce it by about a third, eliminating some material that, although interesting, was not relevant to the topic. What follows is the edited text of that interview.²³

There were two main areas that I wanted to cover in this interview. One had to do with a story of how the HgCdTe research came about, what choices were made and when, what technical challenges were overcome and how. The other had to do with the organization, culture, environment, and personnel at the Research Center that made the HgCdTe research programs so successful in the early 1960s.

My questions to Paul are shown in italics. Following the transcript is a list of papers that Paul referred to during the in-

terview. I inserted reference numbers within brackets where appropriate in the interview text.

The Honeywell HgCdTe effort began in 1960 at the Honeywell Research Center, a corporate research facility that was then located in Hopkins, Minnesota. In 1965, this HgCdTe technology began to be transferred to the Honeywell Radiation Center, an operating division of Honeywell located in Lexington, Massachusetts. Both of these organizations underwent name changes and other changes in the years just before, and subsequent to, the 1980 interview, but in this interview text they are simply and consistently called the Research Center and the Radiation Center.

The Beginning of HgCdTe at Honeywell

REINE: How did the HgCdTe work start at Honeywell, and when? You were there at the beginning?

KRUSE: In about 1960 we began, at the Honeywell Research Center in Hopkins, Minnesota, an internally-funded research effort to look for an 8-12 micrometer intrinsic IR detector working at liquid nitrogen temperature, to look for a material that would be suitable for that. The state-of-the-art was such that 8-12-micrometer detectors were desired for airborne earth mapper systems. But there was no material that worked at liquid nitrogen temperature. There were doped germanium detectors, for example mercury-doped germanium was the most useful one, that worked in the 8-12-micrometer region, but that operated at below 30 K.

There was a zinc-doped germanium detector called a ZIP, zinc impurity photoconductor, that was developed at the Naval Research Laboratory. That was a 40 micrometer detector, operated at four degrees Kelvin. There was copper-doped germanium, which went out to 25 micrometers. Then mercury-doped germanium was developed, and mercury-doped germanium was most useful because it worked in the 8-12 micrometer region, didn't go out much further than that in

²³ Note that the transcribed text has not been edited by DSIAC.

wavelength, and therefore had the highest operating temperature, which was like 30 degrees Kelvin.

The mercury impurity in germanium was first experimented with at Syracuse University in Henry Levinstein's group.

I wouldn't be surprised; a lot of that stuff was done there.

Seb Borrello [3] may have himself measured the activation energy of mercury-doped germanium and found it to be suitable. But because all of Henry's work was funded by the Air Force, they were also concerned with practical applications, and 8-14 micrometers was certainly one of them.

Then, if you look at it from the other point of view, from an intrinsic detector, operating at liquid nitrogen temperature, what was available at the time was lead selenide, and some work on lead telluride...lead telluride never was as good as lead selenide, but that was also a 3-5 micrometer detector. And then the thing that had come along in the 1950s was indium antimonide. Indium antimonide at that time was the best 3-5 micrometer material. The best intrinsic material was indium antimonide because that was a true single-crystal semiconductor, whereas the lead salts were all polycrystalline, difficult to understand the carrier transport and recombination mechanisms in them. So, you had the 3-5 micrometer intrinsic liquid nitrogen temperature detector and, you had the 8-12 micrometer extrinsic 30 degree Kelvin detector. We obviously wanted the combination of the two, the intrinsic 8-12 micrometer detector.

Was it clear, before you started to look for this detector material, that you could get 8-12 micrometer BLIP (Background Limited Infrared Photodetector) detection at temperatures around 77 Kelvin?

Yes. The BLIP theory had been underway. There had been people that had looked at the background limit, including myself. It was understood that, from that point of view alone, it should be possible to get 8-12 micrometer 77 degree Kelvin operational. Although that didn't tell anything about the material; that just told you that if, say, operating in the

photoconductive or the photovoltaic mode at liquid nitrogen temperature, you could achieve a real high D^* in the 8-12 micrometer region.

There was a general appreciation of the fact that intrinsic detectors required less cooling than extrinsic. Although that wasn't really quantified until about 1968, by my Honeywell colleague Don Long. There were two articles that he wrote [4, 5], and he was the one that quantified it. But there was a general appreciation of the qualitative aspect of it then, that extrinsic detectors required more cooling.

Early Infrared Detector Research Efforts and Personnel at Honeywell Research Center

And, of course we had worked on indium antimonide at the Research Center. Actually, that started with work I did on the PEM (PhotoElectroMagnetic) cell when I first went there in 1956. I had met a fellow by the name of the I. M. Ross [6], I think it was, who had visited IT&T where I had worked previously and brought around a PEM cell, an indium antimonide PEM cell, and it was quite fascinating. And so, when I got to Honeywell, basically my first research project was to... I went to work for Don McGlauchlin... was to develop an indium antimonide PEM detector. Don and I just decided casually that would be a nice thing to work on, because he was building up an infrared detector group.

Who else was in the infrared detector research group at that time?

Well, Rich McQuistan. Rich McQuistan and Don McGlauchlin and I and Frank Simon had all come from IT&T. It was called Farnsworth, and then it was called Capehart Farnsworth, and then Farnsworth Electronics, and then IT&T, and we'd all been there. We all came to Honeywell at different times, but during the year of 1956 we all came, first Don and me, then McQuistan and then Simon. We'd all been in the same group back at Farnsworth, back at IT&T. So we knew about lead telluride detectors, we had worked on them. When he got to Honeywell, Don McGlauchlin started working on lead telluride.

Early Effort in Indium Antimonide Infrared Detectors at the Research Center

And then I started on indium antimonide. Indium antimonide and the III-V's were not very old at the time. There was this paper by a German fellow, Herman Welcher. He had shown in 1952 that the III-V's were semiconductors, and he began to synthesize them. Mostly the ones he looked at, if I recall correctly, were indium antimonide and indium arsenide. In fact, he patented the III-V's. He's got the famous Welcher patent that nobody pays attention to, but everybody that makes a gallium arsenide device violates the Welcher patent. Westinghouse tried to collect money from everybody; they were the licensee in the United States. Nobody would pay them anything for it.

But we started working on the PEM cell first. That meant we had to grow indium antimonide. We had pure indium and pure antimony, and we did a Czochralski growth, and we did zone refining on one of the materials.

Then that became a Honeywell product, the indium antimonide PEM cell, and I did that [7]. Well, then Charlie Butter and Don McGlauchlin, I think, began working on a photoconductive indium antimonide detector, which was about 1958 or 1959. They went to zone leveling crystal growth if I recall, and that was successful. The Honeywell Radiation Center in Lexington, Massachusetts had a contract with HRB Singer (Haller, Raymond and Brown - Singer) to deliver a single element, indium antimonide photoconductive detector for the mapper that went in the Army Mohawk aircraft [8].

I'm jumping ahead a little bit when I talk about the indium antimonide photoconductive detector manufacturing that went into the mapper. But the reason I say that is that it laid the ground work for the Honeywell Radiation Center later on, in getting contracts with HRB Singer to substitute photoconductive mercury cadmium telluride for photoconductive indium antimonide.

Early Research on Tellurium at the Research Center

So, Don McGlauchlin and Charlie Butter were working on the photoconductive indium antimonide, and also were looking at photoconductivity in tellurium because we were growing tellurium at the laboratory too.

At our laboratory at that time, there was a lot of interest in tellurium, and we were the foremost growers of tellurium. That wasn't the department that I was in, that was the department that had John Blakemore and Allen Nussbaum and some other people, and a fellow by the name of Tom Davies [9] who was our crystal grower for the laboratory. He managed to grow tellurium crystals in large-diameter ingots by, I think, Czochralski, and prior to that people had just been growing tiny crystals by a Bridgman process or something. Honeywell at that time had become the foremost in the world, I believe, in growing crystals of tellurium [10].

What was the interest in tellurium then? Was it infrared detection or basic research?

No, it was not infrared detection, but basic research. People were interested in tellurium because its electrical properties were not isotropic, and it was a new semiconductor material. After all, at that time you really only had germanium, and people had hardly started to work on silicon, a little bit. Then the III-V's, and that was it. Well, here's tellurium... another material.

Origins of the Infrared Detector Research Group at the Research Center

How did Don McGlauchlin come to set up an infrared detector group at the Research Center?

First, Don McGlauchlin had been a manager of a vacuum tube lab at IT&T. He had a large group of people reporting to him doing development and manufacturing. The tubes were image converters and high-current photomultipliers and things like that. He was hired by the Honeywell Research

Center in April of 1956, April or May, into a group at that time that was called Primary Sensors. The idea was to develop sensors, radiation being one type of sensor, but pressure... what have you. The man that was head of that group hired Don and hired me, and quite soon he left the lab.

Don McGlauchlin became the manager of the department, and it was still Primary Sensors, and we were looking at things other than radiation detection. But my background was in radiation detection, and the other sensors kind of fell by the wayside. As McQuistan came into it, within a year or so it was primarily infrared detection technology.

So, in the absence of some strong divisional thrust, this infrared group developed out of a general interest, a corporate interest in sensors?

Yes.

Mainly because of the people they hired more than...

Yes. It was a "bottoms up" effort rather than a "tops down."

Finn Larsen was the Director of Research. Prior to 1954, when people like Don Long and Karl Nomura, John Blakemore, and Allen Nussbaum were hired, the Research Center was sort of an engineering group, and there weren't any scientists as such, and there were just a few engineers. Then Finn Larsen came and began to look for people with PhDs who were scientists, particularly solid-state people, and so he hired that group and then it expanded. Since they had no history at all, they were trying to do some very good scientific research and at the same time began to think about some potential products for the company.

Incidentally, at that time Honeywell owned a division, the Semiconductor Products Division down in Riviera Beach, and they were manufacturing germanium transistors. The germanium work had originally been done at the Research Center by Nussbaum, Blakemore, Nomura, and Long. They were standing in support of the Riviera Beach division, and Riviera Beach was making germanium power transistors and

was sort of the foremost company to do that, but they were never a successful business enterprise.

Internally Funded Research Project for an Intrinsic 8-12 Micrometer Infrared Detector Operating at 77 K Began in 1960

About 1960, then, I started a research project, which I referred to at the beginning of this interview, to look for an intrinsic 8-12 micrometer material. We also appreciated at that time that you'd like to have a direct gap semiconductor.

As opposed to germanium, which is indirect gap. Why was that?

We went through this analysis of lifetime in our book [11], which was being written at the same time, *Elements of Infrared Technology* by Rich McQuistan, Don McGlauchlin and myself. I wrote the last half of the book, the last five chapters. There I was looking into the theoretical concepts for radiation detection and trying to understand this competition between various recombination mechanisms, and talking with John Blakemore, maybe the world's leading expert in this lifetime on semiconductors.

Was Blakemore's book already written at the time?

He was writing it or just had... it was published in 1962 [12].

Through him being there, with all the lifetime measurements he was making and the analysis he was making and so on, we were getting an appreciation of the fact that there are different lifetime mechanisms, like Auger. We were one of the first ones to talk about Auger recombination.

We find that, in the book, the competition between Auger and radiative lifetime. Of course, we didn't want a Shockley-Read type of mechanism, we would like to have really a fundamental mechanism. You will see a chapter in the book where there is a hypothetical 8-14 micrometer intrinsic material and there is a figure in there that shows the lifetime as a function of temperature, for both n and p type, for both radiative and Auger lifetime (Chapter 9, Figures 9.18 and 9.19,

pages 380-381). Going from room temperature to 77 K or something like that, maybe a little below 77 K. I made some of those calculations and Blakemore made some, I don't remember exactly.

Once you know the lifetime mechanisms then you can predict what the noise would be, and then you can see the noise essentially begin to compete with background noise, and then develop a criterion for BLIP.

There was a general feeling that, in order to get to the BLIP limit, you should have the dominant recombination mechanism be radiative, that was a general feeling. That had come out of this paper by Petritz [13] back in 1954, or maybe it was a 1959 issue of the *Proceedings of the IRE*. There's a *Photoconductivity Conference* volume in 1954 which had the Rittner paper [14] in it, and I think Petritz had a paper in it too, and there was the 1959 issue [15] of the *Proceedings of the IRE*. Between those two, people were beginning to get an appreciation of how detectors really worked and how to optimize them. So then, we started the project then in about 1960, I think.

The direct gap would have the stronger radiative recombination.

Yes. The radiative recombination in an indirect gap material is very weak.

So that ties into why you were looking for a direct gap.

We knew that in transistors, you'd like to have an indirect gap because you wanted to have a long lifetime to get a large gain. That was sort of generally appreciated, germanium is an indirect gap, silicon is an indirect gap. But we believed that in photodetectors you wanted to have it radiative lifetime limited which required a direct gap. Indium antimonide was a direct gap, and so on. So, the question was, how could you get an 8-12 micrometer direct gap material. So, then it switches from a theoretical point of view to a materials point of view.

Candidates for an Intrinsic Semiconductor with a 0.1 eV Bandgap

The candidate materials at that time were mercury selenide...which was our first choice..., mercury telluride, an alloy of indium antimonide and indium arsenide, grey tin, a ternary called copper iron telluride, I think CuFeTe_2 , and so on. There was magnesium tin, magnesium lead $\text{Mg}_2\text{Sn-Mg}_2\text{Pb}$. And of course, mercury cadmium telluride.

And other candidates were thallium antimonide and indium bismuth, and also an alloy of thallium antimonide and indium bismuth.

How did we get at these? Well, take them one at a time. There were some literature reports on mercury selenide that indicated it was a tenth of an electron volt semiconductor, there was just one paper in the literature or something. There was another paper in the literature that indicated that mercury telluride had an energy gap of 0.02 eV. In other words, 20 millielectron volts, one paper on that. Very little in the literature.

And of course, the band structures of both of these materials were still unknown?

Completely unknown band structures.

We weren't the only people, incidentally, that were looking for this. There was an Army contract with Battelle, and there was a Navy contract with Eastman Kodak, and they started about the time we got our Air Force contract, which I'll get to in a little bit. The magnesium tin - magnesium lead alloy work was done at Battelle, because there had been some indication that that was a small gap material. Small gap, by definition at that time, was like a tenth of an electron volt. There was some indication that that material was a semiconductor.

That ternary I mentioned, like copper iron telluride I think it was, that came out of one of Henry Levinstein's reports.

Henry Levinstein was writing annual reports on his Air Force contract. In one of them about that time, he had this list of candidate, small gap materials, semiconductors, candidate semiconductors, small gap materials, that might be useful for infrared detection, and somewhere he got this idea of copper iron telluride. When I asked Henry about it later, he wasn't sure where it came from. I think it came from the Russians. Maybe from a Russian paper translated by the AIP (American Institute of Physics). Henry had in the table that it had a tenth of an electron volt.

Now, the indium-bismuth-thallium-antimony alloy was a rather obvious thing when you go down the III-V's. We knew in general that you'd like to be close to the center of the periodic table because the III-V's are covalently bonded, but the II-VI's and I-VII's were generally ionic bonded. There was a feeling that you wanted to have a covalent material. So, it was rather obvious.

We looked at thallium-bismuth too.

So that was a candidate. Then there was the indium-arsenide, indium-antimonide alloy. There was a report in the literature that when you made the alloy of those two materials, the energy gap, instead of lying between them, went to a minimum at some intermediate point. It was reported that the long wavelength limit would be like 8 or 9 micrometers.

So, when we looked this list over, what did we start working on? Here, I'm not exactly sure which part was done under the contract and which was done not under the contract, prior to the contract.

Is this 1960 or earlier?

This was 1960.

Honeywell Research Center Wins an Air Force Contract to Develop an Intrinsic Semiconductor Detector with a 0.1 Ev Bandgap Operating at 77 K

Let me jump ahead a little bit. Late in 1960, maybe October or something like that, the Air Force came out with an RFP to

do exactly what we had intended to do under our in-house efforts. Exactly the same requirements: 8-12 micrometer intrinsic infrared detector operating at the highest possible temperature, hopefully liquid nitrogen temperature.

When the RFP came out, we had been working three to six months on this project. It was a competitive procurement. I was told later there were 30 companies bidding. We obviously wrote the winning proposal. It had a lot of this theoretical analysis. It had a list of candidate materials. It had a lot of the theoretical analysis as why you might expect an 8-12 micrometer detector to work. I was the proposal manager and other people worked on it.

That contract began in February of 1961. Air Force Contract 336167901. Thad Pickenpaugh was the contract monitor.

How did the Air Force get the idea for the RFP, do you think? Was it Thad's idea, or was it someone else?

They were interested in mappers. I think they supported the mercury-doped germanium work, which Texas Instruments was doing. Maybe some other places, too. Henry Levinstein had done the original development on mercury-doped germanium. The Air Force had been supporting Henry all along. So, the Air Force was interested in detectors. They went out to industry for this contract.

We won the contract. I can't remember exactly when we actually started growing materials, whether it was right at the beginning of the contract or whether we already started the in-house materials growth efforts just before we won the contract.

HgSe and HgTe were the First Two Candidates to be Looked at Experimentally

Somewhere around the first of 1961 we began to work on mercury-selenide. I think it was before we got the contract. Don Blue was working with me on the contract, and I think Charlie Butter or Jim Garfunkel. We grew crystals of mercury-selenide, and selenide and began to measure their electrical properties and look for an absorption edge. We put

them in a spectrometer and looked for an absorption edge and looked for photoeffects. What we found was that the samples were n-type. We measured the Hall coefficient as a function of temperature for different samples. They were highly opaque, out to 14 micrometers, maybe even farther, I can't remember how far out we looked. We got photoeffects. We looked at both photoconductivity and the PEM cell.

About that time, I got these photoeffects and they were suspicious from a variety of points of view. You could get a PEM signal and you could get a photoconductive signal, except that I began to worry about thermal effects because they had a fairly low-frequency roll off. Of course, we had expected about a microsecond or so from our experience with indium antimonide and from this idea of radiative lifetime and what it should be. Instead, we were getting like a millisecond, which was very unusual.

I then considered what thermal effects you could get, that would give rise to a voltage. I found that if you just looked at it fairly simply, in the PEM configuration, that was also the same configuration for a Nernst effect, a thermally excited Nernst effect. And in the photoconductive configuration, that was also the same configuration for a bolometric effect. It was great to get the photosignals, great to get Hall effect data, but we were a little bit suspicious.

Don Blue and I analyzed it and wrote a paper [16], which was published in *J Phys Chem Solids*, on the electrical properties. Blue, Garfunkel and I published a second paper [17] in *Journal of the Optical Society of America*. There, we began to consider HgSe to be a degenerate semiconductor. The photoeffect data we explained in terms of thermal effects rather than true photon excitation.

Our second choice was mercury telluride. Mercury telluride was similar to, and just about as easy to grow as, mercury selenide. That was thought to be a 0.02 eV semiconductor. We grew some mercury telluride. I'm sure we did. That was worse than the mercury selenide in terms of the number of free electrons at any given temperature, but you could get

nominally photoeffects out of it, which at that time we were convinced were thermal effects. Very quickly, we decided that mercury telluride was a semi-metal also.

Somewhere along the line, we looked at, for a short time, indium bismuth and thallium antimony, and also the alloy of indium bismuth and thallium antimony. We were doing crystal growth at the time. I think Tom Davies was doing it. The problem with those materials was that they didn't form any kind of compounds. We didn't spend a lot of time, but when we would react indium with bismuth, we'd get an ingot that had indium in it and had bismuth in it, but no reaction products. Maybe, if you work at it for a long time, you could solve that problem. I don't know. The same with the thallium antimony. It just didn't react. So, we abandoned that.

Attention Shifts to HgCdTe

After looking at mercury selenide and mercury telluride, we decided we wanted to work on mercury-cadmium-telluride. The reason we decided that was that there was a paper [18] in the literature, the famous one by Lawson, Nielsen, Putley and Young published in *J. Phys. Chem Solids* in 1959, that indicated that mercury-cadmium-telluride was a semiconductor, at least over part of the composition range. They had a plot in their paper that showed the energy gap as a function of the alloy composition parameter x , where x is the fraction of cadmium telluride in the alloy. I don't remember what temperature it was for. In fact, I'm not even sure they specified the temperature. From that, it looked like you wanted to have a 10% alloy, that is, 10% cadmium-telluride, 90% mercury-telluride. That would get you a tenth of an electron volt.

Obviously, it was a fairly complicated material to work with because of the problem of explosion. You knew right away, that when you're working with mercury, first of all, it's hard to work with. You knew right away that you couldn't heat it up in an open tube. Second, that even if you put it in some sort of ampule it explodes.

After we'd looked at mercury-selenide and mercury-telluride, our third choice was mercury-cadmium-telluride. I can't remember the indium-bismuth-thallium-antimony approach. I don't remember just exactly where we had that on the list.

We wrote a letter to Thad Pickenpaugh. We were writing contract reports. Maybe it was in the contract report or maybe it was a letter. We listed eight or ten candidate materials. We'd already looked at the first two. We wanted to start working on mercury-cadmium-telluride. We got a letter back from the Air Force to the effect that they didn't want us to work on mercury-cadmium-telluride, because that was already under investigation by the British.

So, I talked to whomever it was that was doing our contract marketing at the time. He wrote a formal legal-type of letter back to Thad, or the Air Force, or whomever it was, saying that we would not be responsible for the technical success of the contract unless we could pick our materials of choice. And then the Air Force wrote back, and they said that's fine. Go ahead. So, our third material was mercury-cadmium-telluride.

HgCdTe Growth Effort Begins in Early 1962

So, we began to grow mercury-cadmium-telluride around the beginning of 1962.

Now, there was some general interest in mercury-cadmium-telluride at other places at the time. My recollection was that a fellow at Eastman Kodak, whose name I think was Don Morey [19] had worked on the lead sulfide detectors at Eastman Kodak. Don Morey had tried to evaporate mercury-cadmium-telluride, because that's the way he was making lead sulfide, by evaporation. He had a Navy contract that he worked on during the early 1960s. He was entirely unsuccessful in terms of any kind of good results. He was trying to evaporate mercury-cadmium-telluride, if telluride if I recall correctly.

The Battelle group, the Army effort, was working on magnesium-tin, magnesium-lead alloy, I think. We, under the Air

Force contract, were working on mercury-cadmium telluride by bulk crystal growth. There was some effort at the MIT Lincoln Laboratory at the time by Alan Strauss and Ted Harmon, I believe. At least Ted was involved, and I think Alan was, too. I'm not sure that they were interested in it at the time for infrared detectors. Alan had been at Chicago Midway Laboratories around 1956, 1957. He was growing indium-antimonide there. He was looking at photoeffects in it, I think, studying the semiconducting properties of it, not interested in a detector *per se* though. Then he went to MIT Lincoln Laboratory and started working with Ted Harmon. They were generally interested in mercury-cadmium-telluride, and telluride and were trying to grow crystals of it.

I think there was some other work going on, too. I think the French work had started about the time we did, too. Madam Verie and coworkers.

There were also some early Polish papers in the early '60s talking about mercury-cadmium-telluride.

About 1960 or 1961, the American Institute of Physics (AIP) began to translate the Russian journals. And by gosh, there were a lot of Russian papers. By a lot I mean maybe half a dozen of them on mercury-cadmium-telluride. But, they never went to a small gap composition. Their compositions that they reported in their scientific journals were always about 70% and up. They were looking at photoresponses in the 1 to 2 micrometer region. I presume it was for security considerations that they didn't report their other work. I can't imagine they didn't work on it for the same reason we did.

We began to try to grow mercury cadmium telluride crystals. We started out right away by having to put them in a sealed ampule, a quartz ampule. I think we started out right away with a 12.7 mm inner diameter. I called it at the time a modified Bridgman method. What we were trying to do was to drop the crystals slowly, at a very slow lowering rate, through a very steep temperate gradient, because we knew about the problem of constitutional supercooling. I think that Harmon and Straus were talking about this at the time, or somebody

else, in general terms, not specifically for mercury-cadmium-telluride. It was important to lower the crystal very slowly through a very steep temperature gradient. Otherwise, you had a bi-stable phenomenon in which you could get two different x-values freezing out. That would give rise to a dendritic structure. That was called constitutional supercooling. We realized you had to get a very steep temperature gradient and a very slow growth rate. So, we were dropping the crystals through a freezing plane.

These had already been compounded?

Yes, my recollection is, we started right from the very beginning with the rocking furnace idea for compounding. We would compound it in an ampule. Then we would take that ampule out of that furnace after it came back down to room temperature. We would have an ingot in there. But it was polycrystalline. Then we would try to drop it through a freezing plane in a vertical furnace, a Marshal Products furnace. We even went so far as to actually have at the very bottom of the furnace a pool of water. Maybe it was oil. Anyway, it was some liquid that was at room temperature. The ampoule would actually lower into that.

There was also the idea of freezing from a large volume. That idea was in the literature. Ted Harmon was trying to follow that procedure. I can't remember what the paper was at the time. We knew of course that we wanted to get a uniform x-value. We had some knowledge of the idea of the phase diagram and the fact that there was a solidus and a liquidus that were separate from each other, and therefore, that as you tried to freeze, you would segregate. We knew that general concept. We knew that therefore you just had a non-uniform composition along the longitudinally, to say nothing of laterally.

We looked into this whole business of freezing from a large volume, where the volume was so large that you could always replenish the excess cadmium in the first-to-freeze part. I think the idea was to make kind of a long, tall ampule, if I recall. We worried about the mixing. We worried about tem-

perature distributions a lot. We bought a Marshal Products furnace that I think we had designed with a large number of taps on it, like 12, so with resistance elements or with Variacs we could profile the temperature within the furnace. We were very concerned about getting the steep temperature gradient. We had models for heat transfer through the quartz tube and up the liquid and solid. We got into that a lot.

Very quickly, as soon as we began to make the material, even though the material wasn't very good quality, we began to look at photoeffects. We began to see them. In fact, we saw some that extended past the 8 to 12 micrometer region.

We were measuring absorption edges, and they were very, very strange. They had all sorts of non-smooth shapes. That was due to the fact that the spectrometer looked at fairly broad region of the sample in which there was a varying composition.

But response times were short?

Yes. We wrote a paper in *Infrared Physics* in early 1962 [20] in which we talked about mercury-selenide, mercury-telluride, and mercury-cadmium-telluride. We talked about this competition between the thermal and photo mechanisms. We were able to show that in mercury-selenide and mercury telluride, the only thing you got were thermal effects, but here in this work with mercury-cadmium-telluride, we got a true photon effect. We published that in 1962. That was just a little sample from one region of a crystal that happened to go beyond 12 micrometers, I think. Maybe it went to 14 or 15 micrometers. That we did at helium temperature. We of course were doing resistivity and Hall also besides transmission. We were doing that down to helium temperature.

We were looking at photoconductivity. We had sort of abandoned the idea of looking at the PEM effect.

Then, because the electron mobility was so high, we began to worry about the μB products (the product of the carrier mobility micrometer and the magnetic field strength B) and

the way you looked at Hall coefficient data. You get magnetoresistance and you get a magneto Hall effect. You had a field dependence of these parameters, which are nominally resistivity and Hall coefficient, which are nominally field independent. You had a field dependence in them. That dependence depended upon what the mobilities were and their ratio, and what the composition was. You had all these strange effects that were showing up when you began to take your Hall data. The Hall coefficient at low fields would be field independent and then start dropping. We were doing a lot of modeling to try to fit and estimate. We didn't know what the mobility values were or anything like that. You're doing it at various temperatures, and you're trying to fit these complicated models that had field dependences in them.

Then, of course, we had these strange things for just the Hall effect in itself. In p-type material, you had the double cross-over type of stuff. In n-type material, instead of just going up and flattening off, instead the Hall coefficient would go up to a peak, come down a little bit and go back up again. Real strange effects. So, it was a very weird and complicated material we were working with.

Explosions All the Time

And then we had the explosions. Explosions all the time. We started out with our first furnace contained in a plywood box. Warren Saur was working as a technician on the thing at that time. We had one monstrous explosion that blew the plywood box apart at the screws. It was screwed together. It pulled the sheets apart. The darn mercury went all over the laboratory. This was in the basement of the old Research Center. Of course, the laboratory was contaminated with mercury. It took us about two weeks to a month to clean that out. It was just like entering Three Mile Island. You could go in there for a few minutes. When you did that, you'd raise a mercury dust. It was embedded in the paint and in the floor and all over. We had a mercury monitor just like radiation monitor. You'd go in there and then you'd start stirring up that dust, and the mercury monitor started to indicate a mercury concentration beginning to rise in there. You could do a

little bit of cleaning, but then you had to get out. Eventually, the only solution to it was to repaint all the walls. We covered up the mercury by repainting.

After the explosion in the box, we went to this steel well-casing. Warren found the original container for the furnace. Incidentally, the ampules, I don't think originally were within a steel pipe within the furnace. That meant that you'd destroy the furnace when the thing went. These are the rocking furnaces I'm talking about. They were homemade, so we could rewind another furnace pretty quickly. But the whole thing was then put inside this big well-casing with the end plates. We vented it all the way up to the roof. So when one of them exploded, it would not destroy anything in the laboratory. The gas vapors would go out on the roof and presumably disperse around there.

True Photoeffects Seen Almost Immediately in HgCdTe

We got photoeffects almost immediately, from the first crystal, I think. Very exciting, because we had a black body set up there and we had a wave analyzer. You used the wave analyzer tuned to the chopper frequency. I can still remember seeing that first needle begin to pin when we opened the shutter. For the first good far-infrared detector, 8-12 micrometer detector, the needle went all the way over to the right. When we started turning the range switch, it was still all the way to the right, until we went a number of orders of magnitude. I think the first detector probably came just a few months after we started looking into mercury-cadmium-telluride.

Bernice Johnson had not gone to college, had no technical training, but she'd worked as a lab technician. She was a person who was really dedicated to whatever she worked upon. One of the things we noticed right away, when you cut into these ingots, was the fact that there was a color cast to them. She was able to associate the "good material" with a pinkish color. She could see it well and I could see it sometimes. Nobody else could see it. We tried to do reflection measurements to actually try to see that region in a spectrometer.

We were never able to actually detect it, but there was very clearly a pinkish cast to it. So, Bernice very quickly got to know where the good material might be in an ingot.

Incidentally, we were looking for 10% material, because of the Lawson, Nielsen, Putley and Young article [18]. We weren't looking for 20%. We didn't know that. We didn't know mobilities. We had these weird effects that had to do with μB products. That was really a difficult thing to work on. We originally thought we needed 10% material, but of course we were working with other compositions, plus the mercury cadmium telluride itself had a great variation.

We were trying to understand what the x-value actually was in a given piece. We were looking at X-ray measurements, and trying to measure the lattice constant, and that was not very sensitive. There was this paper [21] on density in the literature by John Blair and Roger Newnham. Maybe their paper was the first x-ray data. We tried to use electron beam microprobe analysis. We eventually came up with density as being the most reliable method of determining alloy composition. We had to get calibrations on all this. The whole thing was a very iterative procedure.

Once we started on the mercury cadmium telluride we pretty much concentrated on that, and as we began to get photoeffects that clearly extended through the 8 to 12 micrometer region, we really saw we were on to something then.

Interestingly enough, the British had dropped their work completely, and I talked to Putley, I think, about that later. He said, well, their original results were so negative and the doped-germanium looked so attractive that the English efforts switched over to, I think, mercury-doped germanium. They dropped their effort on mercury cadmium telluride, right after that paper apparently. I think that was their only paper on it until later when they restarted their mercury cadmium telluride effort.

We were growing many, many ingots. We were measuring a lot of detector properties and we were reporting these

results at the IRIS meetings. As soon as we got any kind of detection that looked at all promising, we got a Confidential stamp on our work. We could not publish anything in the open literature on the photoeffects. I think we could still publish on the electrical properties. We began to give talks at IRIS meetings and write for Proceedings of IRIS. A lot of our earlier papers, maybe three or four of them, are not in the open literature. They're just in the IRIS proceedings. This would be the '62, '63, '64 timeframe.

Happy Accident in 1964

Well, we have that one magic ingot, of course, 6-18-64, where we name them by the date on which they were compounded, June 18, 1964 in this case. We were growing 6-18-64 over the weekend. We had compounded it in the rocking furnace and put it in a Marshall Products furnace, which is a vertical furnace. We were trying to drop it through a steep temperature gradient.

Over the weekend, one of the Variacs burned out, and the upper part of the ingot was supposed to be molten. Instead it underwent a high temperature anneal. By Monday morning, maybe half the ingot had gone through the freezing plane. The upper half, which had been previously compounded, because the Variac fuse had blown, the upper part of the ingot had not remained in the molten state. When we found this accident had happened, we took the ingot out and simply set it aside, and did not look at it anymore.

Later on in the year, it was five or six months later, Bernice Johnson said that she would like to take a look at that ingot. We had cut into it, I think, or something like that, and she saw some of this pinkish cast. I think maybe she had cut into it on her own, seeing some of that pinkish cast. So, she said she would like to look at that half of it, and we made some detectors out of it. Suddenly, we had a D^* in the ten to the ninth, and it had the right x value. Happened to have the right x-value and had a D^* in the ten to the ninth range. Well, that was very exciting then. We knew we were onto something pretty good.

We were in communication with the Honeywell Radiation Center in Lexington, Massachusetts at the time during this whole thing. They had been manufacturing indium antimonide detectors. Somewhere along the line, I can't remember when, probably in late '64, we gave them a HgCdTe detector, a liquid nitrogen temperature detector, a single element detector which they could compare with the indium antimonide detectors.

Under the HRB Singer contract?

Right, and HRB Singer got quite excited about it and gave the Honeywell Radiation Center a contract to develop an advanced version of the Mohawk Mapper. Mercury cadmium telluride was to be the detector in the advanced version. Honeywell Radiation Center got a contract to develop a single element, mercury cadmium telluride, liquid nitrogen temperature, photoconductive detector for the advanced version of the HRB Singer mapper.

Pivotal Detector Meeting at NRL in Dec. 1964

In December of 1964, there was a fairly significant meeting called by Henry Shenker at Naval Research Laboratory for all the detector companies. Now, the established companies that were in the detector business Santa Barbara Research Center of Hughes and Texas Instruments. Other work was being done at RCA and Westinghouse. Honeywell was sort of an outsider in a certain sense. We didn't have much of an effort going really. We had the one Air Force contract at the Honeywell Corporate Research Center and the one contract with HRB Singer at the Honeywell Radiation Center.

The other established companies were basically working on the extrinsic germanium, mostly mercury-doped germanium. There was this meeting. It was to look at 8 to 12 micrometer detectors. It was a classified meeting at the Naval Research Laboratory. We presented our data on the mercury cadmium telluride. I can remember that the efforts of the established extrinsic detector companies, mostly TI and Santa Barbara, were trying to put our work in disrepute basically. In other

words, they said there was no future to mercury cadmium telluride and the real wave of the future lay in the mercury-doped germanium.

The services were represented, and the established extrinsic detector companies said that's where the services should put all their money, in mercury-doped germanium, not this mercury cadmium telluride. Mercury-doped germanium detectors at that time had a detectivity of maybe a factor of ten higher or something like that. They were starting to make arrays of them. Of course, they were long thin columns sticking up because of the low absorption coefficient. But they believed that and they were trying to beat our work.

Well, anyway, it didn't do them any good. We continued to work on it, continued to get contract support. DARPA became interested, and we got a DARPA contract, I think in about '65. We then had two contracts. We had an Air Force contract and a DARPA contract. The Air Force contract kept on for many years and various versions.

Transition of HgCdTe Technology to the Honeywell Radiation Center Begins in 1965

We were always interested in trying to transfer technology out of the Corporate Research Center to the Honeywell Radiation Center. In late 1964, early 1965, Ray Russell from the Radiation Center came out to the Research Center and spent a week with us and learned how to prepare sensitive elements from pieces of mercury cadmium telluride, single elements, how to lap and polish the material.

These early detector elements had soldered leads. We were mounting them on, I think, germanium substrates. There was a question of how you make the Dewar too. The Dewar was a single element Dewar, liquid nitrogen temperature, standard style, with the Kovar weld rings, but we had to find a new window. We had spent quite a bit of time looking at window materials... germanium, synthetic sapphire, some of the Irtran materials that were just coming out at that time ... and window sealing techniques. We were epoxying them down,

but that was not thought to be a very good method. You really wanted to have a glass-to-glass seal, a standard procedure like that. We were looking at frets for putting between the window material and the barrel of the housing. So, there was work going on in the detector Dewar fabrication area too under the contract.

Ray Russell came out, in I think probably '65, early '65, and spent a week with us and took back to the Radiation Center these methods of making the detector elements and making the Dewars. We started supplying material to the Radiation Center. Jack Lennard was head of the Detection Sciences Group at the Radiation Center at the time. I think we gave the Radiation Center most of the good part, the back...it was 50 to 100 mm...of Ingot 6-18-64 at the time. Jack Lennard coined the term 'tenderloin' for that. Supposedly it was locked up in a safe.

High-Temperature Anneal Becomes Standard Part of HgCdTe Crystal Growth Process

After we realized that this accident, which made good detectors, had resulted in high temperature anneal, and we learned right away that the dendrites were gone from that annealed region, we immediately then began to do a compounding step followed by an annealing step in the Marshall Products furnace. Compound in the rocking furnace, take the ampule out, place the ampule in the Marshall Products furnace and, instead of dropping it through a freezing plane, simply heat it up to 650 degrees and let it sit there. That was a lot better.

We had this lowering mechanism which was an old drill press stand. We had the water underneath it. It was very difficult to do that. This compound/anneal procedure turned out to be a much simpler thing. Somewhere along the line, we realized that 20% was a better estimate than 10% for the 8 to 12 micrometer material. We knew that, and we were then annealing the material instead of trying to lower it through a freezing plane, through the high temperature anneal.

Some of the other stuff was beginning to fall into line. We were beginning to get parts of the material that were sufficiently uniform, so we could begin to make sense out of some of the Hall effect data and other electrical data. We began to get numbers for mobilities that we had some confidence in, particularly for n-type material. P-type material still, of course, had a lot of problems with interpretation of electrical data. It wasn't until Walter Scott came to work at the Research Center and began to look at it that p-type material began to be better understood. In '69 he came up with the idea of lightly doped p-type material, where it actually had an n-type skin. That then began to explain some of these really strange effects we'd been looking at in the p-type material.

We began to get numbers for majority carrier lifetime from frequency response measurements for the photoconductive signal. In '65, '66, '67, we began to get a much better understanding of the material.

In 1964, I got a second contract, a completely different contract from the Army, on what was called a Thin Film Image Converter. Dick Schulze came to work for Honeywell about 1963, and he and I worked together on this contract. So, I was working on two contracts in '64 and '65. The Army contract required a quarterly report, and the Air Force a monthly letter and a quarterly report, or *vice versa*, so I spent an awful lot of time writing reports. It was very aggravating, all the report writing.

I was dividing my time between these two contracts. In '65, I think, Joe Schmit, I don't remember the exact sequence, but basically, Joe took over the direction of the effort in about '65.

It was somewhere around that time that I remember talking to Don Long and listing all the possible things we could publish, in principle, that we had enough information to publish on. Don, I think, was the department manager by then. What happened was Don McGlauchlin got promoted. He became an Assistant Director of the laboratory, Assistant Director of Research.

I was asked to take over that department. I said I would rather not, since I, by that time, was a staff scientist and I felt, at the time, I preferred to do that. They had this dual-ladder structure, whereby supposedly you could get promoted up that side, about equally well as the other side. Supposedly, the perks and everything like that on both sides were equivalent. I emphasize the word supposedly. I told them I'd rather not become the department manager, and Don Long became the department manager. Called acting, but he was acting for a long time.

I wrote this memo to Don Long where I listed all the possible things we could publish, and we discussed it. It was decided that a lot of that material, even though maybe unclassified, was proprietary. The only thing I could publish was the paper [22] that I did publish in *Applied Optics* which was a special issue, if I recall, devoted to infrared technology. Later on that situation eased up a lot. The secrecy order was removed from the Air Force contract. After Joe got well into it, they allowed him to publish a lot of the stuff [23, 24, 25]. Then Warren Saur published a paper [26] in '67 or so, in which he showed a photoresponse at helium temperature going out to 40 micrometers for a low x material like 17% or 18%.

Don Long Systematically Analyzes Fundamental Mechanisms in Infrared Detectors

When did Don Long begin to get involved with mercury cadmium telluride?

I think it was after he became the department manager, which was 1965. He always did things other than pure management. He was always spending maybe 25% of his time doing technical work. He was not doing laboratory work, but he was doing analyses. After he got to be manager of a group whose responsibility was basically electro-optical effects, I think probably called Electro Optics department at that time, most of the things going on were related to infrared detectors.

Don Long started a series of seminars. He was doing his own analysis. He'd start it from very, very basic ideas and build up a body of knowledge in his own mind which he was publishing in these seminars. Others of us were giving parts of the seminar too, but he was building up the whole idea of how infrared detectors work, and others were contributing to it too. He was developing his own feel for this whole thing [4, 5].

Of course, Don had been a solid state physicist, so the solid state part of it came naturally to him, but the photo effects part was something new to him. The whole business of the background limit and things like this, and the competition between recombination mechanisms, and intrinsic versus extrinsic, and so on. He started publishing in this area in about '68 or '69 [4, 5, 27-29].

Walter Scott came aboard and he started working in this area too. He originally tried to look for photo emission from a piece of mercury cadmium telluride by optically pumping it. If it's radiatively limited, you should see that radiation. He was UV pumping and looking with a spectrometer. He was never able to see anything.

It sounds like the idea of having to be radiatively limited to be BLIP persisted for some time?

Yes. It was never thoroughly understood, but that certainly was an idea that was around for a long time.

HgCdTe Gains Momentum at Both the Research Center and the Radiation Center

After about '65, the whole thing gathered an awful lot of momentum. The Radiation Center became very much more involved with the Research Center. The efforts at the both the Research Center and the Radiation Center greatly expanded.

Bob Lancaster grew his first crystal here at the Radiation Center in 1967.

Yes. We transferred the crystal growth technology in '67, and transferred the detector fabrication technology in '65. A lot of people got involved with it at the Radiation Center. The Radiation Center began to gather up a lot of momentum. Our effort at the Research Center became a little bit larger, but very quickly you surpassed us in terms of the number of people working on it. We began, at the Research Center, to get other contracts. Joe Schmit was basically the guy that was the principal investigator, and he began to look at other wavelength regions, such as shorter wavelengths.

There was a lot of interest in three to five micrometers. The fundamental studies part got a lot more expanded. We got the FTS spectrometer. Walter Scott ran that. He began to look at the optical absorption in the material [30]. Ernie Stelzer got involved with it. Obert Tufte got involved in 1966 or '67. Obert was a staff scientist, and we got a contract from ARPA, I think, to try to develop an epitaxial method of growth. Obert was working with Ernie Stelzer, and they worked on this so-called close space transport method [31] in a sealed tube where you had the source piece and the cadmium telluride substrate very close to each other. You heat them up in a furnace and you get some source material transporting over to the substrate. They began to make layers there, which it turned out were very uniform laterally, but very nonuniform away from the surface, but otherwise they were working on that in '67 and '68, in that timeframe.

It takes a long time before you can transfer a technology, and there weren't that many examples of things that were transferred out of the Research Center. When we transferred the mercury cadmium telluride detector technology to the Radiation Center in '65, that was looked upon very favorably, and I got a H. W. Sweat award for that. That was awarded in '66, which was the first year. There were three Sweat awards given out of our laboratory in 1966 for work done in '65.

You can see that there must have been a pretty positive attitude at that time toward the work, because it was something that was beginning to pay off basically, for our laboratory. There were other things that were being done there too, a lot

of good magnetics work that was paying off to the Honeywell Avionics Division in Florida, such as magnetic plated wire memory. It was looked upon quite favorably.

HgCdTe Rapidly Gained Acceptance in the Army Common Module FLIR Applications

When did you join the Army Scientific Advisory Panel?

1965.

All along, of course, the mercury cadmium telluride technology was proceeding and becoming more and more entrenched. And, once you got the idea of the Common Module FLIR, which was developed... TI began to develop that in the early 70s under contract.

Incidentally, Manny Gale and I suggested that concept to the Army. We suggested it in about 1970.

We had a meeting with Pat Daly and Don Loft. Manny Gale is a civilian and a part of the army staff. He and I set up a meeting at which we called in Don Loft and Pat Daly to the Pentagon and suggested the concept of a modular way for FLIRs so that you could use them in different applications as a way of going to volume, and met with a very negative response from Daly and Loft at the time. But, it must have taken hold in their minds because about a year or two later they let the contract to TI. TI developed the Common Modular FLIR technology beginning at about '72.

Once the Army began to see the first FLIRs, they just fell wildly in love with them. The Army, I mean the users, the important people who are out there using the equipment, and they're the people that can, say, go back and say to DARCOM, the developer, "Hey, that stuff is just marvelous." Once you began to see that, then you knew that this whole thing was going to take off. Not only that, but you knew mercury-cadmium-telluride was then very deeply entrenched. Not only that, but you knew that second generation technology was a long way off, a long way off from a user point of view. Might

be fairly close to being here from a technology point of view but, if you understand the way that the Army system works, in which you go through all these ASARCs and DSARCs to get something, a product, and it takes close to 10 years to get the product out in production.

The so-called IOC, Initial Operational Capability, typically takes 10 years, and the thing stays in production for at least 10 years, 10 or 15 years. The way that changes are made is not to throw away something and replace it but rather product-improve it. It happens in all major weapon systems, and you begin to adopt the point of view that says that when you've got billions of dollars invested in this FLIR technology, Common Module FLIR technology, there's no way that you're going to make stepwise changes. You can only make product improvement type of changes.

This means that it's very hard to introduce second-generation technology, which is staring arrays ... I'm talking about staring array technology... into those existing applications, which are the Tank Thermal Sight (TTS), the Advanced Attack Helicopter's (AAH) Pilot Night Vision System (PNVS) and Target Acquisition Designation System (TADS), and the TOW night sight, the Dragon night sight, and things like that. Second generation technology really belongs in missile seekers and sensor fused munitions where you don't have an existing product that you have to displace. Rather now, you've expanded the applications sphere and now you've got a new application and you're looking at something maybe that will not be put into production until 1985 timeframe and therefore you can ... maybe later than that. Therefore, you can make your decisions now as to the best available technology. You don't have to displace anything.

So that's I think where second generation's going to fit.

APPENDIX A REFERENCES

1. Reine, M. B. "Interview With Paul W. Kruse on the Early History of HgCdTe, Conducted on October 22, 1980." Cambridge, MA, 2 July 2014.
2. Reine, M. "Paul W. Kruse (1927 – 2012), In Memorium." *Proceedings of The International Society for Optical Engineering (SPIE)*, vol. 8704, 2013.
3. Borrello, S. R., and H. Levinstein. "Preparation and Properties of Mercury-Doped Germanium." *J. Appl. Phys.*, vol. 33, pp. 2947–2950, 1962.
4. Long, D. "On Generation Recombination Noise in Infrared Detector Materials." *Infrared Physics*, vol. 7, pp. 169–170, 1967.
5. Long, D. "Generation Recombination Noise Limited Detectivities of Impurity and Intrinsic Photoconductive 8 μ Infrared Detectors." *Infrared Physics*, vol. 7, pp. 121–128, 1967.
6. Hilsun, C., and I. M. Ross. "An Infra-red Photocell based on the Photoelectromagnetic Effect in Indium Antimonide." *Nature*, vol. 179, no. 146, 19 January 1957.
7. Kruse, P. W. "Indium Antimonide Photoelectromagnetic Infrared Detector." *J. Appl. Phys.*, vol. 30, pp. 770–778, 1959.
8. Reine, M. B. "History of HgCdTe Infrared Detectors at BAE Systems." *Proceedings of SPIE*, vol. 7298, 2009.
9. Davies, T. J. "Growth of Tellurium Single Crystals by the Czochralski Method." *J. Appl. Phys.*, vol. 28, pp. 1217, 1957.
10. Blakemore, J. S., D. Long, K. C. Nomura, and A. Nussbaum. "Tellurium." In *Progress in Semiconductors*, vol. 6, pp. 39–84, edited by A. F. Gibson, London: Heywood & Company Ltd., 1962.
11. Kruse, P. W., L. D. McGlauchlin, and R. B. McQuistan. *Elements of Infrared Technology: Generation, Transmission and Detection*. New York: Wiley, 1962.
12. Blakemore, J. S. *Semiconductor Statistics*. Pergamon Press, 1962.
13. Petritz, R. L. "The Relationship Between Lifetime, Limit of Sensitivity, and Information Rate in Photoconductors." In *Photoconductivity Conference*, pp. 49, edited by R. G. Breckenridge, B. R. Russell and E. E. Hahn, New York: Wiley, 1956.
14. Rittner, E. S. "Electron Processes in Photoconductors." In *Photoconductivity Conference*, p. 215, edited by R. G. Breckenridge, B. R. Russell and E. E. Hahn, New York: Wiley, 1956.
15. Petritz, R. L. "Fundamentals of Infrared Detectors." *Proceedings of the IRE*, vol. 47, no. 9, pp. 1458–1467, September 1959.
16. Blue, M. D., and P. W. Kruse. "Preparation and Electrical Properties of Mercury Selenide." *Journal of Physics and Chemistry of Solids*, vol. 23, no. 6, pp. 577–586, June 1962.
17. Blue, M. D., J. H. Garfunkel, and P. W. Kruse. "Long-Wavelength Photoeffect in Mercury Selenide." *J. Optical Soc. America*, vol. 51, no. 12, pp. 1408–1410, 1961.
18. Lawson, W. D., S. Nielsen, E. H. Putley, and Y. S. Young. "Preparation and Properties of HgTe and Mixed Crystals of HgTe-CdTe." *J. Phys. Chem. Solids*, vol. 9, pp. 325–329, 1959.
19. Morey, D. R., and S. Sheldon. "Optically Immersed Photoconductive Cells." U.S. Patent 3,239,675, Eastman Kodak Company, Rochester, New York, 8 March 1966.
20. Kruse, P. W., M. D. Blue, J. H. Garfunkel and W. D. Saur. "Long Wavelength Photoeffects in Mercury Selenide, Mercury Telluride and Mercury Telluride-Cadmium Telluride." *Infrared Physics*, vol. 2, pp. 53–60, 1962.
21. Blair, J., and R. Newnham. "Preparation and Physical Properties of Crystals in the HgTe-CdTe Solid Solution Series." In *Metallurgy of Elemental and Compound Semiconductors*, vol. 12, pp. 393, Wiley Interscience, 1963.
22. Kruse, P. W. "Photon Effects in Hg_{1-x}Cd_xTe." *Applied Optics*, vol. 4, pp. 687–692, 1965.
23. Long, D., and J. L. Schmit. "Mercury-Cadmium Telluride and Closely Related Alloys." In *Semiconductors and Semimetals*, vol. 5, edited by R. K. Willardson and A. C. Beer, New York: Academic Press, 1970.
24. Kruse, P. W., D. Long, and O. N. Tufte. "Photoeffects and Material Parameters in Hg_{1-x}Cd_xTe Alloys." *Proc. Third International Conference on Photoconductivity*, pp. 223–229, edited by E. M. Pell, New York: Pergamon Press, 1971.
25. Schmit, J. L., and E. L. Stelzer. "Temperature and Alloy Compositional Dependences of the Energy Gap of Hg_{1-x}Cd_xTe." *J. Appl. Phys.*, vol. 40, pp. 4865–4869, 1969.
26. Saur, W. "Long Wavelength Mercury-Cadmium Telluride Photoconductive Infrared Detectors." *Infrared Physics*, vol. 8, 1968.
27. Long, D. "Photovoltaic and Photoconductive Infrared Detectors." In *Topics in Applied Physics: Optical and Infrared Detectors*, edited by R. J. Keyes, Berlin: Springer-Verlag, 1980.
28. Long, D. "Calculation of Ionized-Impurity Scattering Mobility of Electrons in Hg_{1-x}Cd_xTe." *Phys. Rev.* vol. 176, pp. 923–927, 1968.
29. Long, D. *Energy Bands in Semiconductors*. New York: Wiley, 1968.
30. Scott, M. W. "Energy Gap in Hg_{1-x}Cd_xTe by Optical Absorption." *J. Appl. Phys.*, vol. 40, pp. 4077–4081, 1969.
31. Tufte, O. N., and E. L. Stelzer. "Growth and Properties of Hg_{1-x}Cd_xTe Epitaxial Layers." *J. Appl. Phys.*, vol. 40, p. 4559, 1969.

APPENDIX B.

Eyewitness Account of FLIR Development²⁴

This appendix provides Kirby Taylor's account of both the FLIR technology development history and the working culture of the times. Taylor was a major contributor to FLIR development at TI and had many experiences as a field support engineer during the Vietnam War.

B.1 FIRST FLIR

As this development was underway in 1964/1965, our boss, Jim Crownover loved to bring visitors to the lab to show off the new technology. One of the notable visitors was Lucien Biberman from the Institute of Defense Analysis. He wanted to talk to engineers and technicians to get the real "skinny" as he said. Lots of questions for us in the lab and he appeared satisfied. Then he wanted to see at more distance, so we rolled the breadboard sensor on a lab "gurney" out into the nearby hallway. Luc turned to me and said, "Now tell me when you cannot see my hands anymore." With that he walked down the hall waving his arms, until I called him to stop. Then he walked back saying, "Well you can see a human hand at 150 feet." I don't remember the distance exactly, but it doesn't matter. That visit started a friendship that lasted for many years.

Later in the summer of 1965, we conducted flight tests and demonstrations in Dayton for the Air Force customer, Merle Carr, at the Avionics Lab, now AFRL, and for others who were interested. The original Wright Field was still in use, now closed, and we could taxi almost to the customer's office. A number of Air Force personnel took turns in groups of five or six to see the airborne demo. We used a pre-World War II vintage DC-3 as our flight test and demo vehicle. After a number of takeoff and landings in this old bird, one of the

janitors in a nearby building saw the activity and thought we were showing off the old airplane. He came to me and asked if he could also have a ride in the old antique.

A few days later we were in Washington, DC at National Airport for more demonstrations. There we met Mr. Biberman once more. Our Washington staff had contacted many others in the customer community and had so many to sign up to fly that scheduling was necessary. Well, Luc saw all this and put his name on multiple flights, day and night. Most of the territory we covered was city with buildings, streets, river/land contrast and other easy infrared scenes. He was very pleased, asking questions, suggesting different flight routes and other such requests.

That series of demonstrations lasted two days and one night. As I remember we made 21 flights. National Airport was not the same after that. Upon our departure we were asked if this was our last takeoff for the day. Then the controller said, "Don't come back soon."

Continuing on to Fort Monmouth, New Jersey we planned to land at Monmouth County Airport. The pilot could not contact the tower, so we landed anyway. What a surprise there! The charts showed a 5500 foot runway, but we discovered it was about half that length. Apparently, some construction project was underway and the airport was essentially closed. Quick reaction by our pilot, Joe Truhill, saved our day. He ground looped the DC-3 and quickly re-applied power to keep us from going over a cliff. Taxiing back to the control tower we discovered not only was it not manned, but the windows were broken out!

We were invited to Eglin AFB in Florida to evaluate the system as a candidate to be installed on an AC-47, Puff the Magic Dragon, for evaluation in Vietnam. There was a comparison with another FLIR sensor and the TI system was selected. Things moved fast then. TI and the Avionics Lab customer

²⁴ Note that this personal account was not edited by DSIAC.

both were against deploying a breadboard, but the flight demonstrations in Washington, DC and other locations had gotten a lot of positive attention.

The in-country evaluation named Red Sea revealed a lot of performance requirements that should be addressed. Sensitivity and resolution improvements were foremost. Environmental issues were also important. A breadboard system in a leaky airplane during the Southeast Asia monsoon season was a real problem. Installation constraints with the sensor pointed forward and the guns pointing to the side certainly conflicted.

All these issues provided good lessons for future systems in the AC-130 Gunships. The AC-130 Spectre became a major contributor to the war effort and is still an important weapon platform today.

B.2 AC-130 SPECTRE FIRE CONTROL SYSTEMS, AN/AAD-4, AN/AAD-6, AN/AAD-7

A hurry-up program to build and deploy the first AC-130 Gunship systems generated a few problems. Some design errors along with imperfect documentation made the equipment support difficult. The first three aircraft were deployed to Ubon Royal Thai Air Force Base in Thailand. A new weapon system, new sensors, and limited operator experience made for a perfect storm.

I was selected to go to Ubon and correct the problems. Before leaving I met with our Senior Vice President, Ray McCord. He told me his expectations and I told him I would do my best, but I had never had the cover off a system of this design. His reply was, "That qualifies you."

Upon arrival in Bangkok I contacted the TI tech rep at Ubon. He said to be at the military side of the Bangkok airport and they would pick me up at 8:00PM. I did as directed and checked in with the NCO at the military desk. He asked my business and I told him I was to meet a C-130 at 8:00PM. He told me that the courier plane had already arrived and left

for the day and would not return until the next day. It was fine with him if I wanted to wait there and sleep on the hard bench.

Well, just as planned, there was a roar of engines outside at exactly 8:00PM. The NCO jumped up and ran to the door just in time to see a Spectre Gunship taxi into place with all the guns pointed at his office. Then two civilians got off and helped me with my bags. You should have seen the look on his face!

We got airborne and the pilot, Lt. Col. Kinninger, who was the squadron Executive Officer came back and introduced himself. He said, "Mr. Taylor, your equipment does not work, and we will take a little trip over some of Laos to show you just how it doesn't work." That certainly emphasized the issues for me. I saw very poor, almost unusable, performance. We finally landed at Ubon and I found a place to sleep. Early next morning, Lt. Col. Kinninger called, saying, "Good morning Mr. Taylor. You have been on this base for 6 hours now. What is your progress?"

At the flight line I discovered three Gunships with three broken FLIRs. We needed to do a lot of trouble shooting and desperately needed spare parts. I was batting 0.000, 0 for 3. A rumor said another Spectre was due from the US in a few hours. Good, that would now be 1 for 4, batting .0250. It arrived and guess what? The cryogenic cooler had failed. Back at 0.000, 0 for 4.

Long hours, some good luck, and we got two birds airworthy. Next, we discovered that the operators had not seen any trucks during missions up to that time. Quite a problem since the mission was predominately traffic interdiction to stop supplies from the north. I decided to fly a few missions to help the operators, and to try to understand the airborne problems. Improvements began to happen. Messages back and forth to TI Dallas helped identify problems and solutions. We got a team together to support the program at Ubon and progress was fast.

Lt. Col. Jim Krause was assigned to the program as operator/instructor. He made so much difference in training others and operating the equipment. His experience with the earlier FLIRs in other programs was so valuable. When I first arrived, no trucks had been detected. After the support team got into place, and the operators became proficient with the equipment, we began to account for up to 400 trucks per month, confirmed kills.

I returned to Dallas and joined the team assigned to redesign and flight demonstrate an improved system. A lot of the problems had to do with a very early application of integrated circuits for the parallel amplifiers. Grounding problems, wiring problems, temperature sensitive electronics all together presented quite a set of problems.

Along with other engineers I advocated that we abandon the integrated circuits and replace them with more conventional electronics: transistors, resistors, and capacitors. There was just one problem – not enough room for 400 channels of amplifiers. We had sold the system based on 400 channels,

so customer buy-in was necessary.

Our senior vice president, Ray McCord addressed the problem head on. He said, "I don't care about all the theory that says 400 is better than 200. If you can't make 400 work, then it is not better." This "new theory" took a bit of time to persuade the analysts and system engineers. Ray called all the team together one Saturday morning in his big conference room. He stated his theory simply, and told us that we had to decide as a group what the solution should be, and be unanimous. "Oh, by the way", he said, "no one can leave this room until a decision is made. No coffee break, no restroom break, no food." The decision was rapid. We went to work. In three weeks we flew for the first test.

Optical design changes eventually provided more than enough sensitivity improvements to overcome the channel-count losses, and the program became very successful.

APPENDIX C.

First FLIR Optics and Scanner Configuration

This appendix describes the optical design of the first airborne FLIR used in combat for ground object targeting in about 1965 during the Vietnam War. As explained in Chapter 5, prior infrared imaging systems were down-looking line scanners, or "mappers," used for intelligence collection. They

were not suitable for real-time targeting because they did not provide fast-framing, real-time imagery and were not directable. For infrared imaging systems to work for targeting, they had to overcome these limitations. This situation posed challenges for the optical design because of the constraints posed by the multiplexing electronics, detector limitations, and displays of that era. Figures C-1 through C-4 illustrate the optical configurations used to be compatible with these constraints. Their role in the development process of the first FLIR was described in Chapter 5.

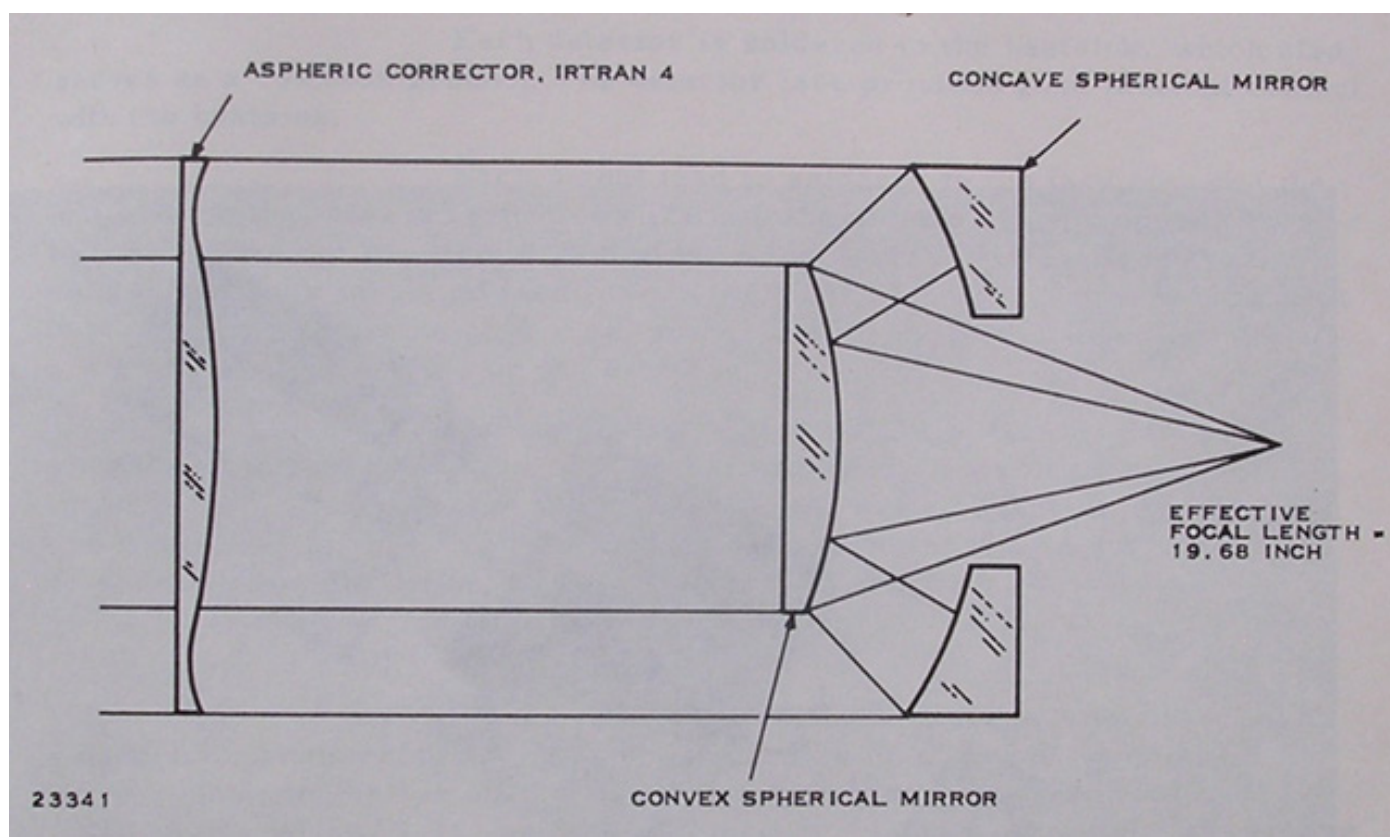

Figure C-1. FLIR I Objective Lens Design – Schmidt-Cassegrain (Source: Kirby Taylor).

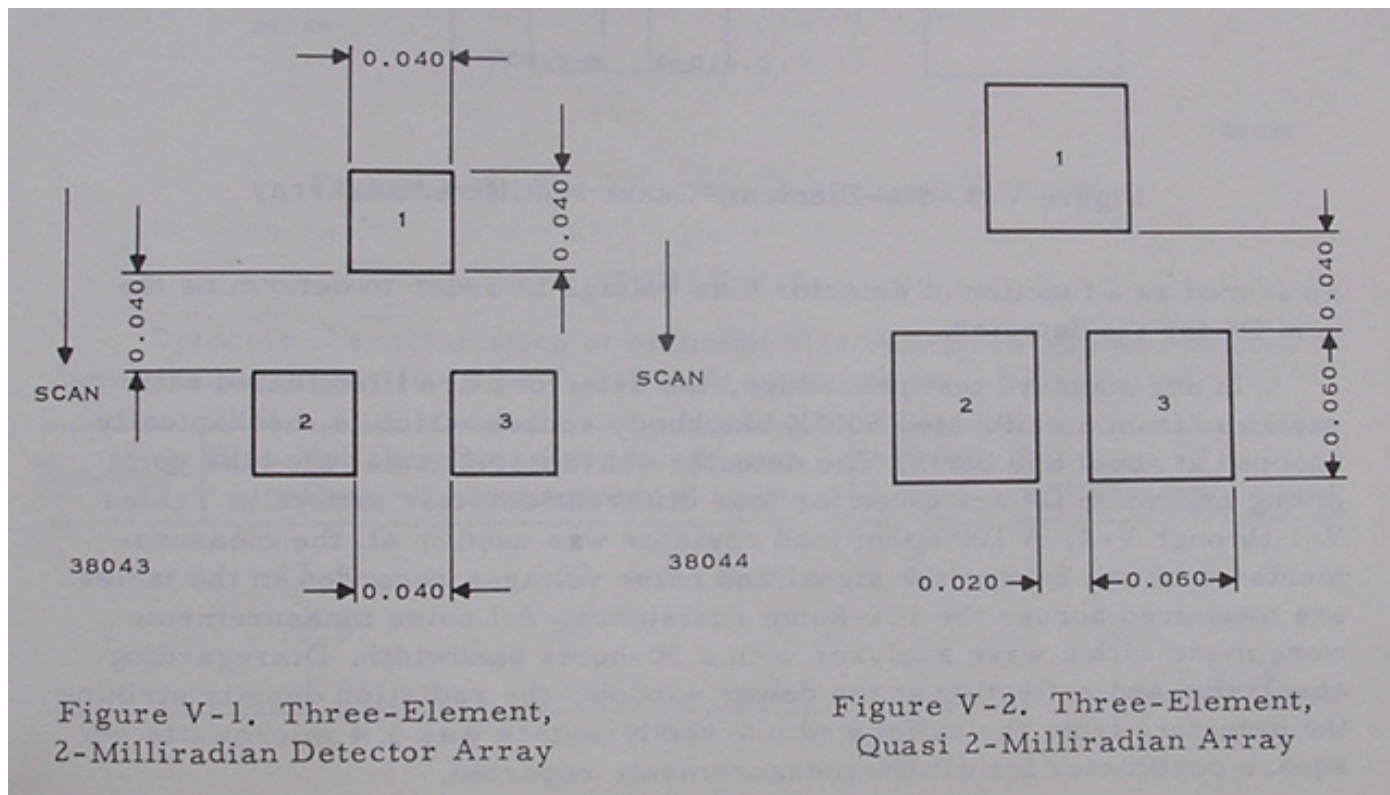

Figure C-2. FLIR I Three-Element Staggered Detector Array (Source: Kirby Taylor).

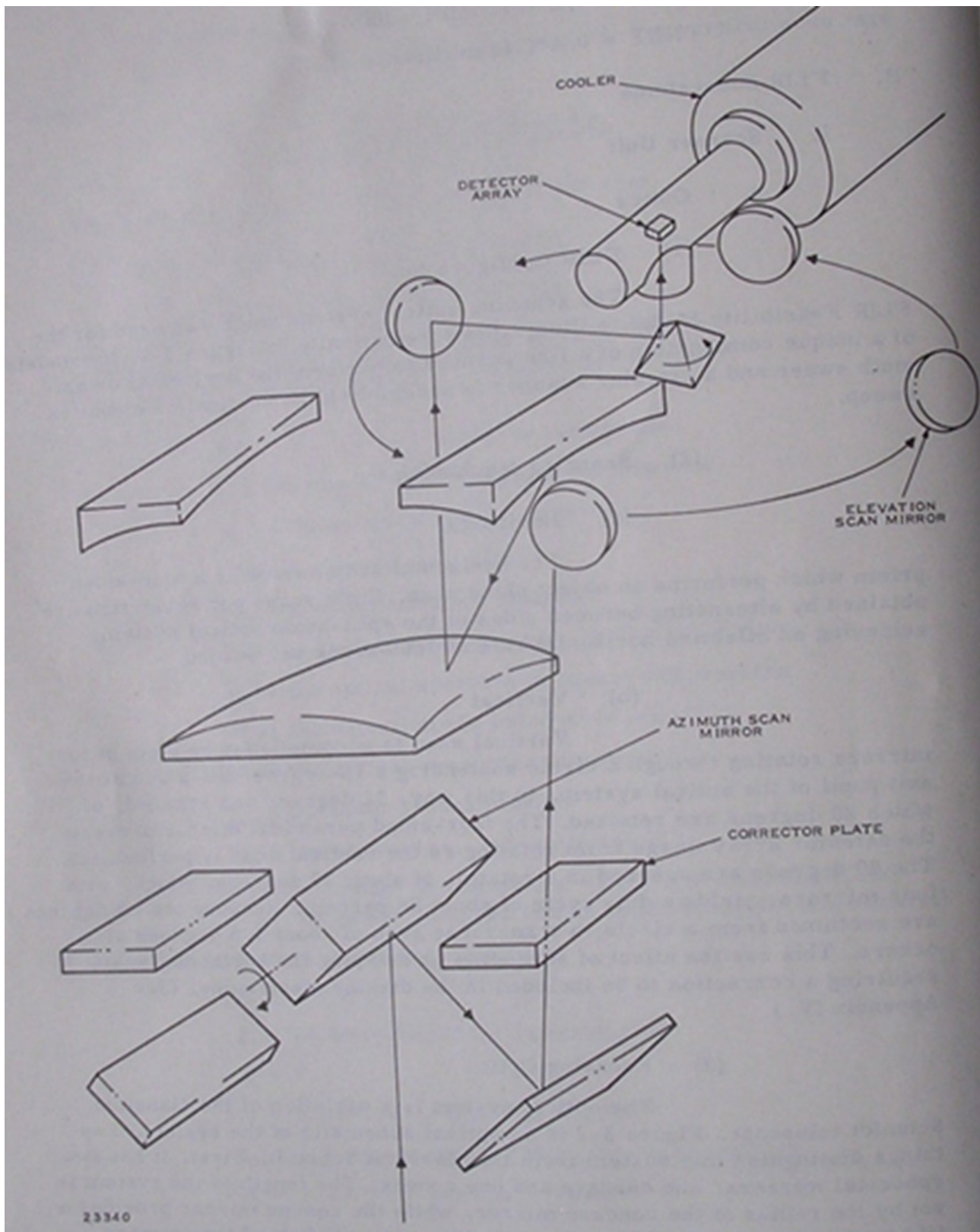
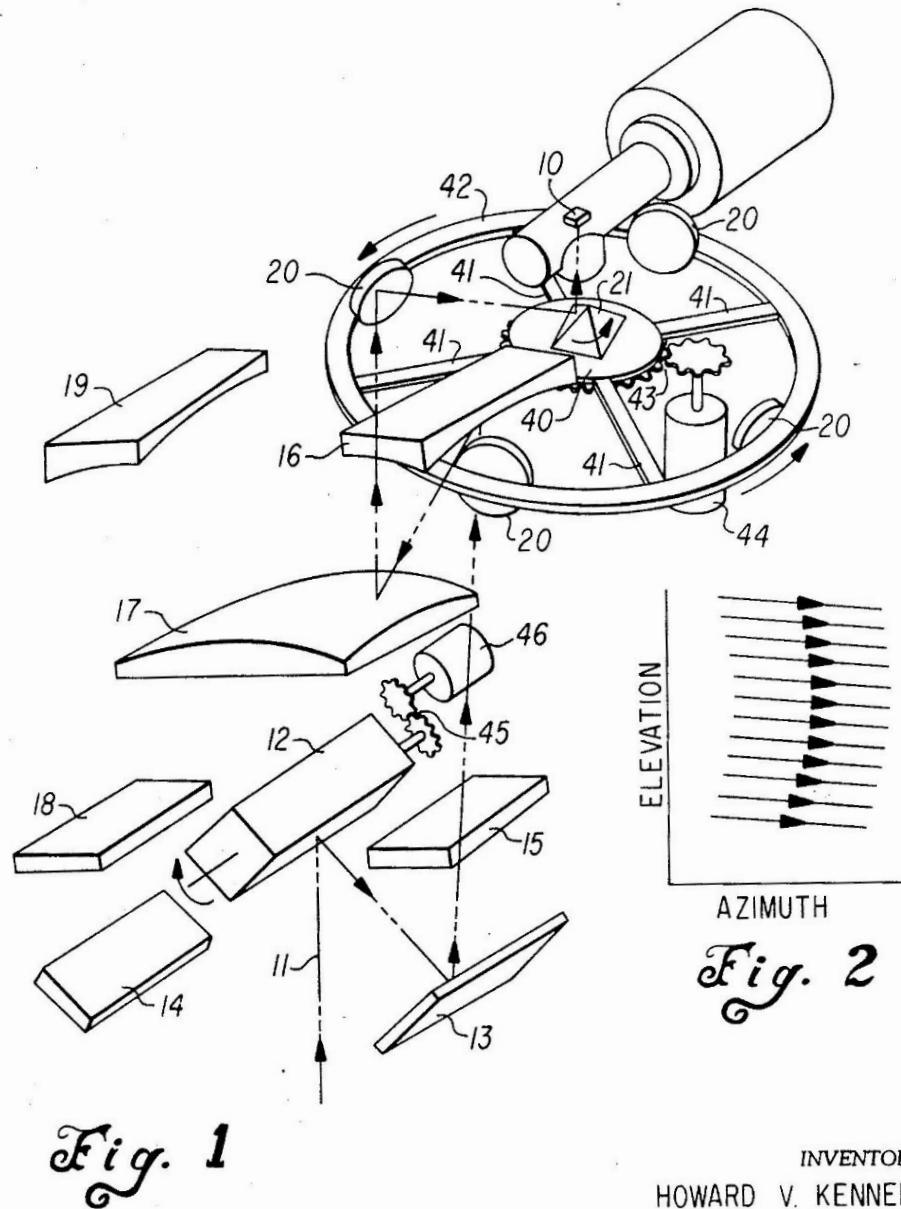

Figure C-3. FLIR I Kennedy Scanner Implementation (Source: Kirby Taylor).

INFRARED OPTICAL SYSTEM UTILIZING CIRCULAR SCANNING

Filed May 3, 1966

2 Sheets-Sheet 1



INVENTOR
HOWARD V. KENNEDY

René E. Gossman
Attorney

Figure C-4. Kennedy 2-Axis Scanner Patent Drawing (Source: U.S. Patent 3,554,628; applied for in 1966).

APPENDIX D.

GEN 1 Common Module Description²⁵

This appendix contains a detailed description of the GEN 1 common modules as provided by Charles Hanson. Hanson witnessed their development as a member of the Army NVL common module development and qualification team.

The detector was a linear array of photoconductive HgCdTe elements on 4-mil centers. The pixels were initially as 2-mil × 2-mil, but it was found that performance and image quality could be improved by changing the sensitive area to 1.6 mils wide (in the scan direction) and 2.4 mils high. The reduced width improved the MTF but reduced the signal-collecting area and, therefore, the responsivity. The increased height made up for the lost area and also made a more pleasing image because pixel overlap resulting from scan interlace reduced the streaking that resulted from poorly corrected response nonuniformity. The electrically-active width of the pixel was significantly wider than 1.4 mils, but the excess width was masked to avoid IR absorption, as illustrated in Figure D-1. The purpose of the masked region was to increase the minority carrier lifetime, which increased the photoconductive gain. Electron-hole pairs created by photon absorption in the optically-active region would spread by diffusion, and they would also be swept to the electrodes by the applied bias field – holes to the cathode and electrons to the anode. Recombination at the electrodes reduced the effective lifetime. Since holes were less mobile than electrons, the expanded region was less in the direction of the cathode. The detector material – both the optically exposed area and the masked area – was coated with ZnS, which served as a passivation layer and as an anti-reflection (AR) coating.

The Dewar was glass with a glass cold stem for receiving the cold finger of a cryogenic cooler. Gold leads, one for each pixel plus a few grounds, ran down the cold stem, each to

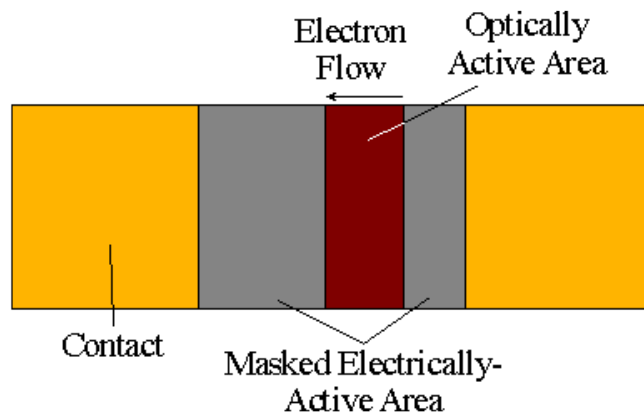

Figure D-1. Layout of Common Module Detector Pixel. (Source: U.S. Army)

a feed-thru at the warm end of the stem. The outside top of the Dewar was a germanium window, metalized on its perimeter and soldered onto a matching metalized ring. The window was AR coated on both surfaces for best transmission in the 7.5micrometer to 12.75micrometer spectral band. The AR coating contained thorium, which included a radioactive isotope, and which, at the time, was a material necessary for the fabrication of durable LWIR coatings. As a result, Common Dewar Modules Dewars were marked for disposal as radioactive material.

There was quite a bit of discussion concerning the location of the bias resistors. Locating them on the preamplifier boards made for an easier implementation, but then the preamp boards were matched to a Detector/Dewar Module, and neither could be replaced without replacing all. The final decision was to make them a part of the Detector/Dewar Assembly. The resistors were trimmed to optimize the signal-to-noise ratio for each element.

The Detector/Dewar Modules came in three versions: 180×1, 120×1, and 60×1. The 180-element modules were used mostly for airborne application, the 120-element modules for ground-based vehicular applications, and the 60-element modules arrays for man-portable applications such as anti-ar-

²⁵ Note that Hanson's description of GEN1 Common Modules was not edited by DSIAC.

mor missiles and night observation devices. The 60-element man-portable detector array is shown in Figure D-2. Figure D-3 shows the larger Common Module Detector/Dewar Assembly with the cover removed. The same Dewar was used for both the 180- and the 120-element arrays.

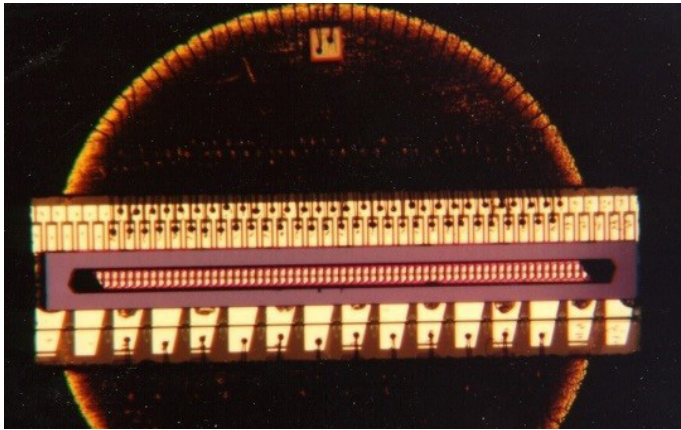

Figure D-2. 60-Element Common Module TOW Detector Array. (Source: U.S. Army)

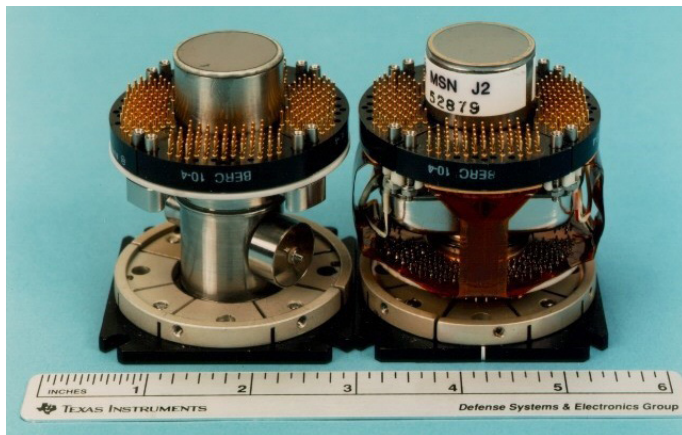

Figure D-3. Common Module Detector/Dewar with cover removed. (Source: U.S. Army)

The Common Module Cryocooler was a Stirling-cycle machine with an included compressor moving orthogonally to the cold finger, which contained the regenerator. The regenerator was a hollow polyimide cylinder containing a stack of stainless steel wire mesh discs randomly rotated. The cooler housing was a low-porosity cast aluminum alloy, except for the cold finger, which was stainless steel. Bearings for the

compressor piston and the regenerator were originally splitting Rulon washers, but later versions improved reliability by using more robust materials. The cold finger mated with the 180-element Dewar by means of a thin corrugated copper cap, the corrugations producing a flexibility that prevented the pressure of the cold finger from breaking the bottom of the Dewar cavity. The cooling capacity was nominally 1 Watt at 77K.

The 60-element Detector/Dewar initially mated with a Joule-Thomson cryostat that was not part of the Common Module set. A smaller, ¼-Watt cooler was soon developed for use with the smaller Detector/Dewar.

Figure D-4 shows the Common Module One-Watt Cooler. The motor is contained in the finned compartment labeled "Motor Housing". The compressor piston is located below the label "P Axis", and the cold finger (without the copper interface cap) protrudes to the lower left. The Dewar attaches to the flange at the warm end of the cold finger. Figure D-5 shows both Cooler/Dewar Assemblies - the 1-Watt cooler with a 180-element Detector/Dewar Assembly attached and the ¼-Watt Cooler with a 60-element Detector/Dewar Assembly attached.

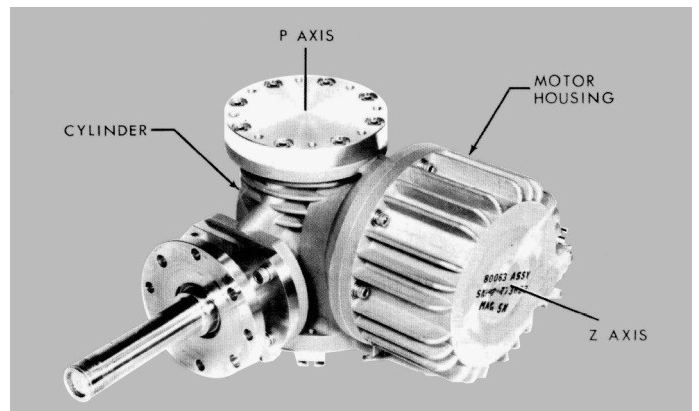

Figure D-4. Common Module One-Watt Cryocooler. (Source: U.S. Army)

The scanner had a single flat mirror, optimized for IR on one side and for visible on the other. It was bidirectional, with the option of a slight tilt between the two directions to provide

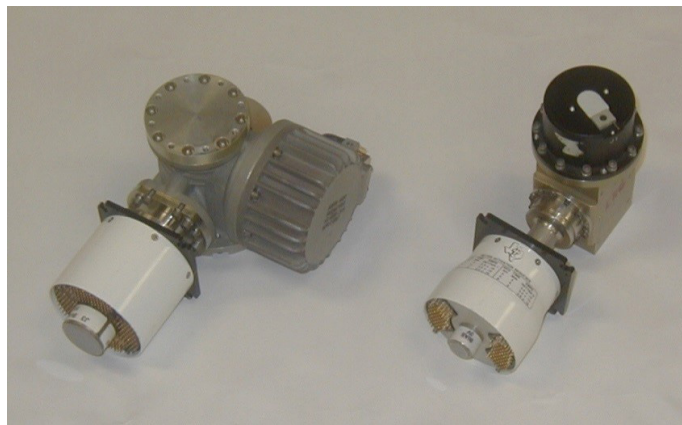

Figure D-5. Common Module Detector/Dewar/Cooler Assemblies for the 180-element version and the 60-element version. (Source: U.S. Army)

interlace. The normal operating speed was 30 Hz, producing two fields during each cycle, but it could also operate at up to 60 Hz / 120 fields per second. The scan angle could be adjusted to provide a 2:1 field of view for any of the detector/Dewar options. The scan efficiency was nominally 70%. The scanner had four optical interfaces. The detector looked at the IR side of the mirror and into the IR imager. Opposite the detector was the LED array, which emitted into the visible collimator and into the visible side of the mirror, where it would reflect into either a system-specific eyepiece or the electro-optical multiplexer. Because of the electronic delay between the detector array and the LED array, the image was slightly offset horizontally when viewed through the scanner. When the scanner reversed directions, the offset was also reversed, producing a horizontal misalignment between the two fields. The visual channel of the scanner included a phase shift lens that moved slightly between fields to keep them optically aligned.

The IR imager was designed to receive collimated IR radiation and focus it onto the detector array. Its focal length was 2.67 inches, resulting in a 0.75 mrad instantaneous field of view (IFOV). The vertical field of view was 5° for the 60-element array, 10° for the 120-element array, and 15° for the 180-element array. The scanner was adjusted differently for each array in order to produce a horizontal field of view that doubles the vertical. The IR imager was intended to interface

with a system-level a-focal telescope which, when combined with the IR imager, would produce the net focal length required for the specific application.

The Light Emitting Diode Module was a 180-element array for all applications. Its elements were very narrow, 1.25 mils, for improved MTF. The height of each element was 3.25 mils to improve the uniformity of the display. The spectral emission was red, in the 620-650 nm range. The balancing resistors for the LED array were contained within the LED Module.

Between the LED Module and the Scanner Module was the visible collimator, which collimated the light from the LED Module and reflected it off the visible side of the scanner mirror. From the scanner mirror, light was directed into either optics for direct view or into an electro-optical multiplexer.

The Preamp Module included 20 channels of bias resistors and first-stage amplification for the detector. By breaking the preamplifier function into 20-channel circuit cards, the boards were a manageable size given the technology of the day, and they could be assembled in multiples to match the number of detectors in whichever array option was being used. The bias resistors were trimmed according to the specific Detector/Dewar Module being used to normalize the responsivity of the detector elements. This meant that the Preamp Module boards were not interchangeable once they were normalized.

The PostAmp Module was also implemented in 20-channel circuit cards. Since the detector bias resistors were trimmed to optimize the signal-to-noise ratio for each element, and since the LED array was itself normalized, the task of normalizing responsivities was left to the PostAmp Module. It was implemented by means of a potentiometer for each channel. This adjustability permitted the free interchange of PostAmp boards, although doing so required a normalization procedure.

BIBLIOGRAPHY

- Barr, E. S. "The Infrared Pioneers – I. Sir William Herschel." *Infrared Physics*, vol. 1, 1961.
- Barr, E. S. "The Infrared Pioneers – II. Macedonio Melloni." *Infrared Physics*, vol. 2, 1962.
- Barr, E. S. "The Infrared Pioneers – III. Samuel Pierpont Langley." *Infrared Physics*, vol. 3, 1963.
- California Institute of Technology. "Thermoelectrics: Caltech Materials Science." <http://www.thermoelectrics.caltech.edu/>, accessed 4 September 2012.
- Cool Cosmos. <http://coolcosmos.ipac.caltech.edu>, accessed 27 August 2013.
- Earth Observatory. "Samuel Pierpont Langley (1834-1906)." https://earthobservatory.nasa.gov/Features/Langley/langley_2.php, 3 May 2000.
- Herschel, W. *The Scientific Papers of Sir William Herschel*. London, England: The Royal Society and the Royal Astronomical Society of England, 1912.
- Holden, E. S. *Sir William Herschel His Life and Works*. New York: Charles Scribner's Sons, 1880.
- Holmes, R. *The Age of Wonder: The Romantic Generation and the Discovery of the Beauty and Terror of Science*. New York: Harper-Collins, 2008.
- Hong, G. "Thomas Johann Seebeck." *Speech and Hearing Science Historical Review*, New Taipei City, Taiwan: Fu Jen Catholic University, 2003.
- Hoskin, M. "William Herschel." *New Dictionary of Scientific Biography*, vol. 3, New York: Charles Scribner's Sons, 2008.
- Infrared Training Institute. "Macedonio Melloni." <https://infraredtraininginstitute.com/infrared-thermography-history/macedonio-melloni/>, accessed 4 September 2012.
- Mahidol University. "Mahidol Physics Education Centre." Nakhon Pathom, Thailand, <http://mpec.sc.mahidol.ac.th/>, accessed 4 September 2012.
- Millman, P. M. "The Herschel Dynasty - Part One: William Herschel." *Journal of the Royal Astronomical Society of Canada*, vol. 74, pp. 134, 1980, <http://adsabs.harvard.edu/full/seri/JRASC/0074/0000134.000.html>, accessed September 2012.
- Mullaney, J. "Herschel's Telescopes." *The Herschel Objects and How to Observe Them*, Springer Science & Business Media, pp. 10, 2007, <http://books.google.com/books?id=HFg2sOjrFtsC&pg=PA10>, accessed 5 June 2011.
- Redd, N. T. "William Herschel Biography." Space.com, <https://www.space.com/17432-william-herschel.html>, 4 September 2012.
- Rousse, D. R. "A Brief Review of the History of Radiative Transfer." *Proceedings from the Third International Conference on Thermal Engineering: Theory and Applications*, 21–23 May 2007.
- Steinicke, W. "'The Scientific Papers of Sir William Herschel' at 100." *Astronomy & Geophysics*, vol. 53, no. 2, 1 April 2012.
- Students for the Exploration and Development of Space (SEDS) USA. "The Messier Catalog." <http://messier.seds.org/>, 25 February 2008.
- Universität Innsbruck. "Melloni's Thermo Couple, 1831." <http://physik.uibk.ac.at/museum/en/details/electr/melloni.html>, accessed 4 September 2012.

ACRONYMS AND ABBREVIATIONS

AFAL	Air Force Avionics Laboratory	GE	General Electric
AFB	Air Force Base	Ge:Hg	Mercury-Doped Germanium
AMC	Army Materiel Command	GEN2	Second Generation
APC	Armored Personnel Carrier	GTPE	Georgia Tech Professional Education
APE	Advanced Production Engineering	GTRI	Georgia Tech Research Institute
ATIRCM	Advanced Threat Infrared Countermeasure	HAC	Hughes Aircraft Corporation
CCB	Configuration Control Board	HgCdTe	Mercury Cadmium Telluride
CCD	Charge Coupled Device	HHTV	Handheld Thermal Viewer
CdTe	Cadmium Telluride	HSI	Hyperspectral Imaging
CdZnTe	Cadmium Zinc Telluride	IAC	Information Analysis Center
CERDEC	Communications-Electronics Research, Development and Engineering Center	IDA	Institute for Defense Analysis
CID	Charge Injection Device	IDCA	Integrated Detector Dewar Assembly
CINFAC	Counterinsurgency Information Analysis Center	IEEE	Institute of Electrical and Electronics Engineers
CMOS	Complementary Metal-Oxide-Semiconductor	IMH	Integrated Multiplexed Hybrid
COTR	Contracting Officer's Technical Representative	InSb	Indium Antimonide
CRT	Cathode Ray Tube	IR	Infrared
CTE	Coefficient of Thermal Expansion	IRCM	Infrared Countermeasure
DARPA	Defense Advanced Research Projects Agency	IRE	Institute of Radio Engineers
DAS	Distributed Aperture Sensor	IRIA	IR Information and Analysis
DoD	Department of Defense	IRIS	Infrared Information Symposium
DROIC	Digital Read-Out Integrated Circuit	IRST	Infrared Search and Track
DTIC	Defense Technical Information Center	JLC	Joint Logistics Commanders
EM	Electromagnetic	JOSA	Journal of the Optical Society of America
EO	Electro-Optical	JPL	Jet Propulsion Laboratory
ERDL	Engineer Research and Development Laboratories	JTCG	Joint Technical Coordinating Group
FFRDC	Federally Funded Research & Development Center	LED	Light-Emitting Diode
FLIR	Forward-Looking Infrared	LLLTV	Low Light Level Television
FOV	Field of View	LN2	Liquid Nitrogen
FPA	Focal Plane Array	LPE	Liquid Phase Epitaxy
FPN	Fixed-Pattern Noise	LWIR	Long-Wave Infrared
GaAs	Gallium Arsenide	MBE	Molecular Beam Epitaxy
		MCT	Mercury Cadmium Telluride
		MIS	Metal-Insulator-Semiconductor
		MOCVD	Metal Organic Chemical Vapor Deposition
		MOSFET	Metal-Oxide-Semiconductor Field Effect Transistor

MRT	Minimum Resolvable Temperature	RACIC	Remote Areas Conflict Information Center
MSS	Military Sensing Symposia	RCA	Radio Corporation of America
MTADS	Modern Target Acquisition and Designation Sight	RDECOM	Research, Development, and Engineering Command
MTF	Modulation Transfer Function	RF	Radio Frequency
MWIR	Medium-Wave Infrared	ROIC	Read-Out Integrated Circuit
MWR	Missile Warning Receiver	RRE	Royal Radar Establishment
Nd:YAG	Neodymium-Doped Yttrium Aluminum Garnet	SADA	Standard Advanced Dewar Assembly
NET	Noise Equivalent Temperature	SBRC	Santa Barbara Research Center
NETD	Net Equivalent Temperature Difference	SENSIAC	Sensing Information Analysis Center
NIMS	Near IR Mapping Spectrometer	SOAR	State-of-the-Art Report
NIR	Near Infrared	SPIE	Society of Photo-Optical Instrumentation Engineers
NRL	Naval Research Laboratory	SPRITE	Signal Processing in the Element
NUC	Nonuniformity Compensation	SWaP-C	Size, Weight, Power, and Cost
NVESD	Night Vision & Electronic Sensors Directorate	SWIR	Short-Wave Infrared
NVL	Night Vision Laboratory	TDI	Time Delay and Integration
ONR	Office of Naval Research	TE	Thermoelectric
P3I	Preplanned Product Improvement	THAAD	Terminal High-Altitude Area Defense
PACE	Producibile Alternative to CdTe Epitaxy	TI	Texas Instruments
PbS	Lead Sulfide	TI2S	Thallous Sulfide
PbSe	Lead Selenide	TOW	Tube-Launched, Optically Tracked, Wire-Guided
PC	Photoconductive	TRAM	Target Recognition and Attack Multisensor
PCB	Printed Circuit Board	TRIM	Trails and Roads Interdiction Mission
PM	Program Manager	UV	Ultraviolet
PtSi	Platinum Silicide	VIMS	Visible/IR Mapping Spectrometer
PV	Photovoltaic	VLWIR	Very Long-Wave Infrared
QE	Quantum Efficiency	WWI	World War I
QWIP	Quantum Well IR Photodetectors	WWII	World War II

THE HISTORY OF FORWARD-LOOKING INFRARED (FLIR)

*By Dr. James "Ralph" Teague
and David Schmieder*

DSIAC PUBLICATION DSIAC-2021-1342

DISTRIBUTION STATEMENT A
*Approved for public release;
distribution is unlimited.*

